



The Municipality of the Village of Lions Bay

REQUEST FOR PROPOSAL (RFP)

RFP.17.10

For

**CLOSE PROXIMITY BRIDGE INSPECTIONS,
REPORTS AND LOAD RATINGS**

Village of Lions Bay
PO Box 141-400 Centre Rd,
Lions Bay BC, V0N 2E0

1. GENERAL INFORMATION

Issue Date:	August 18, 2017
Information Meeting:	At the time of issuance of this Request for Proposal (“RFP”), a meeting has not been scheduled (See section 2.1 of this RFP).
Closing Date:	Proposals shall be submitted by no later than September 5, 2017 (the “Closing Date”) at 4:00pm. <i>Proposals will be accepted between 10:00 AM and 4:00 PM only.</i> The Village of Lions Bay’s Offices are closed on Wednesdays, weekends, and statutory holidays.
Address for Proposal Delivery:	The Proponent shall only submit the Proposal (including Schedule C in this RFP) to the Municipality by mail/hand at: Village of Lions Bay Municipal Offices PO Box 141-400 Centre Rd, Lions Bay BC, V0N 2E0 <i>The Proponent shall submit two (2) hard copies and one (1) digital copy on a USB all within a sealed envelope.</i> Proponents should phone reception at (604) 921-9833 to confirm receipt of their proposal.
RFP Inquiries / Municipal Representative:	Naizam (Nai) Jaffer, Public Works Manager Telephone: (604) 921-9833 Email: njaffer@lionsbay.ca
<i>See section 4.4 of this RFP.</i>	
Addenda Process:	If the Municipality determines that an amendment is required to this RFP, the Municipality will issue an addendum that will form part of this RFP and post the addendum on the BC Bid Website at www.bcbid.gov.bc.ca (the “BC Bid Website”) and upon posting on the BC Bid Website, the addendum will be deemed to form part of this RFP. Upon submitting a Proposal, Proponent will be deemed to have received notice of all addenda that are posted on the BC Bid Website.

2. TABLE OF CONTENTS

1. GENERAL INFORMATION	2
2. TABLE OF CONTENTS	3
3. INTRODUCTION	4
3.1. PURPOSE	4
3.2. DEFINITIONS	4
4. INSTRUCTIONS TO PROPONENTS	5
4.1. INFORMATION MEETING	5
4.2. AMENDMENTS TO PROPOSALS.....	5
4.3. LATE PROPOSALS	5
4.4. INQUIRIES.....	5
4.5. EXAMINATION OF CONTRACT DOCUMENTS AND SITE	5
4.6. OPENING OF PROPOSALS	5
4.7. STATUS INQUIRIES.....	6
5. PROPOSAL SUBMISSION FORM AND CONTENTS	6
5.1. FORM OF PROPOSAL.....	6
5.2. SIGNATURE	6
5.3. NET PRICING ON PROPOSAL	6
6. EVALUATION AND SELECTION	6
6.1. EVALUATION TEAM	6
6.2. EVALUATION CRITERIA	6
6.3. LITIGATION	7
6.4. ADDITIONAL INFORMATION.....	7
6.5. INTERVIEWS	7
6.6. MULTIPLE PREFERRED PROPONENTS.....	8
6.7. NEGOTIATION OF CONTRACT AND AWARD	8
7. GENERAL CONDITIONS	8
7.1. PROPONENT'S EXPENSES	8
7.2. NO TENDER	8
7.3. CONFLICT OF INTEREST	9
7.4. SOLICITATION OF COUNCIL MEMBERS, MUNICIPAL STAFF AND MUNICIPAL CONSULTANTS.....	9
7.5. CONFIDENTIALITY	9
SCHEDULE A – SCOPE OF SERVICES	10
SCHEDULE B – DRAFT AGREEMENT.....	15
SCHEDULE C – FORM OF PROPOSAL.....	40

3. INTRODUCTION

3.1. Purpose

The purpose of this RFP is to select a Proposal for the provision of close proximity bridge inspections, reports and load ratings on the Municipality's bridges (see Schedule A).

3.2. Definitions

In this RFP the following definitions shall apply:

- (a) **"Agreement"** means a formal written contract between the Municipality and a Preferred Proponent to provide the Services, the preferred form of which is attached as Schedule B;
- (b) **"Municipality"** means the Village of Lions Bay;
- (c) **"Municipal Representative"** has the meaning set out in section 4.4;
- (d) **"Contract"** has the same meaning as Agreement;
- (e) **"Contractor"** means the company/person that is hired under the Agreement to provide the Services;
- (f) **"Evaluation Team"** means the team appointed by the Municipality to evaluate the Proposals in accordance with Part 6 of this RFP;
- (g) **"Exceptions and Departures"** means Schedule C-1 to the form of Proposal attached as part of Schedule C.
- (h) **"Information Meeting"** has the meaning set out in section 4.1 of this RFP;
- (i) **"Preferred Proponent(s)"** means the Proponent(s) selected by the Evaluation Team to enter into negotiations for a Contract;
- (j) **"Proponent"** means an entity that submits a Proposal;
- (k) **"Proposal"** means a proposal submitted in response to this RFP;
- (l) **"RFP"** means this Request for Proposals;
- (m) **"Services"** has the meaning set out in Schedule A of this RFP; and
- (n) **"Site"** means the place or places where the Services are to be performed.

4. INSTRUCTIONS TO PROPONENTS

4.1. Information Meeting

At the time of issuance of this RFP a meeting has not been scheduled.

4.2. Amendments to Proposals

Proposals may be revised by written amendment, delivered to the location set out above, at any time before the Closing Date but not after. An amendment shall be signed by an authorized signatory of the Proponent in the same manner as provided by section 5.2.

4.3. Late Proposals

Proposals received after 4:00 p.m. on the Closing Date may be rejected by the Municipality in its absolute discretion.

4.4. Inquiries

All inquiries related to this RFP should be directed in writing to the person named in section 1 of this RFP (the “**Municipal Representative**”). Information obtained from any person or source other than the Municipal Representative may not be relied upon.

Inquiries should be made no later than five (5) days before Closing Date. The Municipality reserves the right not to respond to inquiries made within five (5) days of the Closing Date. Inquiries and responses will be recorded and may be distributed to all Proponents at the discretion of the Municipality.

Proponents finding discrepancies or omissions in the Contract or RFP, or having questions as to the meaning or intent of any provision, should immediately notify the Municipal Representative. If the Municipality determines that an amendment is required to this RFP, the Municipal Representative will issue an addendum in accordance with section 1 of this RFP. No oral conversation will affect or modify the terms of this RFP or may be relied upon by any Proponent.

4.5. Examination of Contract Documents and Site

Proponents will be deemed to have carefully examined the RFP, including all attached Schedules, the Contract and the Site (as applicable) prior to preparing and submitting a Proposal with respect to any and all facts which may influence a Proposal.

4.6. Opening of Proposals

The Municipality intends to open Proposals in private but reserves the right to open Proposals in public at its sole discretion.

4.7. Status Inquiries

All inquiries related to the status of this RFP, including whether or not a Contract has been awarded, should be directed to the Municipal Representative.

5. PROPOSAL SUBMISSION FORM AND CONTENTS

5.1. Form of Proposal

Proponents should complete Schedule C - Form of Proposal. The schedules attached to Schedule C consisting of the following:

C-0 – Proponent Information

C-1 – Exceptions and Departures

C-2 – Questionnaire

C-3 – Pricing Proposal

Proponents are encouraged to use the forms provided and attach additional pages as necessary.

5.2. Signature

The legal name of the person or firm submitting the Proposal should be inserted in Schedule C. The Proposal must be signed by a person or persons authorized to sign on behalf of the Proponent.

5.3. Net Pricing on Proposal

All pricing shown on the Proposal is to be net, with Goods and Services Tax, (and Provincial Sales Tax if applicable), shown separately. All other taxes, duties, insurance in freight, customs clearance and other costs are to be included in the net price.

6. EVALUATION AND SELECTION

6.1. Evaluation Team

The evaluation of Proposals will be undertaken on behalf of the Municipality by the Evaluation Team. The Evaluation Team may consult with others including Municipal staff members, third party consultants and references, as the Evaluation Team may in its discretion decide is required. The Evaluation Team may give a written recommendation for the selection of a Preferred Proponent or Preferred Proponents to the Municipality.

6.2. Evaluation Criteria

The Evaluation Team will evaluate and may compare all Proposals to determine the Proponent's strength and ability to provide the Services in order to determine the Proposal which is most

advantageous to the Municipality. It is anticipated that the Evaluation Team will use the following criteria as part of its evaluation:

- | | |
|--|-----|
| (a) Experience, Reputation and Resources | 30% |
| (b) Technical; Approach and Methodology | 30% |
| (c) Pricing Proposal | 40% |

The Evaluation Team will not be limited to the criteria referred to above, and the Evaluation Team may consider other criteria that the team identifies as relevant during the evaluation process. The Evaluation Team may apply the evaluation criteria on a comparative basis, evaluating the Proposals by comparing one Proponent's Proposal to another Proponent's Proposal. All criteria considered will be applied evenly and fairly to all Proposals.

The Evaluation Team reserves the right to not complete a detailed evaluation of a Proposal if the Evaluation Team concludes, having undertaken a preliminary review of the Proposal, that the Proponent or Proposal as compared to all the Proposals is not in contention to be the selected Proposal.

6.3. Litigation

In addition to any other provision of this RFP, the Municipality may, in its absolute discretion, reject a Proposal if the Proponent, or any officer or director of the Proponent submitting the Proposal, is or has been engaged directly or indirectly in a legal action against the Municipality, its elected or appointed officers, representatives or employees in relation to any matter.

In determining whether or not to reject a Proposal under this section, the Municipality will consider whether the litigation is likely to affect the Proponent's ability to work with the Municipality, its consultants and representatives and whether the Municipality's experience with the Proponent indicates that there is a risk the Municipality will incur increased staff and legal costs in the administration of the Contract if it is awarded to the Proponent.

6.4. Additional Information

The Evaluation Team may, at its discretion, request clarifications or additional information from a Proponent with respect to any Proposal, and the Evaluation Team may make such requests to only selected Proponents. The Evaluation Team may consider such clarifications or additional information in evaluating a Proposal.

6.5. Interviews

The Evaluation Team may, at its discretion, invite some or all of the Proponents to appear before the Evaluation Team to provide clarifications of their Proposals. In such event, the Evaluation Team will be entitled to consider the answers received in evaluating Proposals.

6.6. Multiple Preferred Proponents

The Municipality reserves the right and discretion to divide up the Services, either by scope, geographic area, budget availability, fiscal year, or other basis as the Municipality may decide, and to select one or more Preferred Proponents to enter into discussions with the Municipality for one or more Contracts to perform a portion or portions of the Services.

6.7. Negotiation of Contract and Award

If the Municipality selects a Preferred Proponent or Preferred Proponents, then it may:

- (a) enter into discussions and/or negotiations with the Preferred Proponent(s) to attempt to finalize the terms of the Contract(s), including financial terms and scope of services;
- (b) enter into a Contract with the Preferred Proponent(s); and
- (c) if at any time the Municipality reasonably forms the opinion that a mutually acceptable agreement is not likely to be reached within a reasonable time, give the Preferred Proponent(s) written notice to terminate discussions, in which event the Municipality may then either open discussions with another Proponent or terminate this RFP and retain or obtain the Services in some other manner.

7. GENERAL CONDITIONS

7.1. Proponent's Expenses

Proponents are solely responsible for their own expenses in preparing, and submitting Proposals, and for any meetings, negotiations or discussions with the Municipality or its representatives and consultants, relating to or arising from this RFP. The Municipality and its representatives, agents, consultants and advisors will not be liable to any Proponent for any claims, whether for costs, expenses, losses or damages, or loss of anticipated profits, or for any other matter whatsoever, incurred by the Proponent in preparing and submitting a Proposal, or participating in negotiations for a Contract, or other activity related to or arising out of this RFP.

7.2. No Tender

This RFP is not a tender and does not commit the Municipality in any way. By submitting a Proposal and participating in the process as outlined in this RFP, Proponents expressly agree that no contract of any kind is formed under, or arises from, this RFP, prior to the signing of a formal written Contract. The Proponent may cancel or revoke its Proposal at any time until signing of a formal written Contract. The Municipality may cancel the RFP process at any time until signing of a formal written Contract.

7.3. Conflict of Interest

A Proponent shall disclose in its Proposal any actual or potential conflicts of interest and existing business relationships it may have with the Municipality, its elected or appointed officials or employees. The Municipality may rely on such disclosure.

7.4. Solicitation of Council Members, Municipal Staff and Municipal Consultants

Proponents and their agents will not contact any member of the Municipality's Council, staff or consultants with respect to this RFP, other than the Municipal Representative named in section 1 of this RFP, at any time prior to the execution of a contract or the cancellation of this RFP and which could be viewed as one Proponent attempting to seek an unfair advantage over other Proponents.

7.5. Confidentiality

All submissions become the property of the Municipality and will not be returned to the Proponent. All submissions will be held in confidence by the Municipality unless otherwise required by law. Proponents should be aware the Municipality is a "public body" defined by and subject to the *Freedom of Information and Protection of Privacy Act* of British Columbia.

SCHEDULE A – SCOPE OF SERVICES

Introduction / Objective

The Village of Lions Bay (the “Municipality”) invites proposals from experienced specialized engineering firms in response to the Request for Proposal (RFP) RFP.17.10 “Close Proximity Bridge Inspections, Reports and Load Ratings.” The objective of this project is to inspect the 8 vehicular bridges within the Municipality’s jurisdiction that require a detailed, close proximity inspection by a qualified inspector.

Project Specifics

Access: All of these bridge inspections will require the use of some specialized equipment to access all of the bridge components, and proposals should clearly identify the methodology to ensure all girders and beams will be viewed and inspected at close proximity. The Contractor shall include supply of all equipment necessary to provide access to all parts of the bridge and specialized equipment required to assess the bridge condition. The Contractor must also determine the best method to safely and thoroughly inspect and field mark deficiencies on all the identified components.

Traffic Control: It will be the Contractor’s responsibility to provide traffic control notifications and implement all traffic control procedures required. Traffic delays must be kept to a minimum and where possible, single lane alternating traffic must be provided for. Traffic delays exceeding 30 minutes will need to be scheduled with Municipal staff to ensure appropriate public communication takes place.

Inspection Schedule: At least ten days prior to the contract commencement, the Contractor shall submit the final inspection schedule to the Municipality for review. This schedule shall include the structure number, the inspection date and the approximate time of all activities.

Communication: The Contractor’s proposal shall also identify a communications protocol for the notification of serious deficiencies found during field inspections.

Existing Documentation: The Municipality will provide what documentation it has to the successful Contractor. The Contractor will review drawings, documents, and previous reports PRIOR to commencement of fieldwork.

Non-Destructive Testing (NDT): Advanced NDT is not anticipated at this time; however, the Contractor’s proposal may include unit pricing for NDT as an option for each bridge. In some cases, cursory testing procedures will be required during the inspection to better evaluate the condition of particular structural elements. These includes hammer sounding of timber and concrete elements to identify possible timber rot; concrete delamination; and wire-brushing of corroded steel elements to measure section loss.

Individual Material Testing: Based on the results of the visual evaluation, additional tests may be required to gain a more in-depth understanding on the performance of the structures. Thus, the successful

proponent shall provide unit prices or hourly rates, inclusive of disbursements and travelling, for the following tests:

- Timber Drilling Tests on wood structures
- Loading Rating Analysis
- Concrete delamination survey (chain drag)
- Concrete coring including strength, air void analysis, chlorite ion content, and PH
- Ultra-sonic impact test
- Half-cell testing

Load ratings: The results of load ratings must include a summary detailing the rationale for any factors used and contain calculations, in a clear logical format. Load ratings shall be calculated using current code requirements.

Inspection Process Criteria: The procedure of inspection is primarily based on the recording and rating of observed structural defects identified during a thorough examination of the structure. The following methodology shall be used in the inspection:

- Inventory photographs shall be taken of the structure to show the general configuration, site conditions, and other such background information not necessarily relating to defective components of the bridge. Inventory photographs are normally used during subsequent inquiries for evaluation of site conditions.
- In a methodical step-by-step approach, all elements of the structure shall be inspected at close proximity (preferably within one metre), evaluated, and rated.
- A condition rating shall be given for each element. If a defect exists, then the percentage rating of the element affected is given a reduced rating. The rating system will require the inspector to account for the effect of the defect on functionality and relevance to the structural integrity of the structure. The rating system to be used is summarized in the following table:

Rating "R"		Structural integrity and safety of user	Functionality - secondary to structural integrity. Does it perform as originally designed?	Maintenance priority and urgency of repair	Urgency "U"	
					Monitor	M
5	Excellent	No Defects	New Condition - No Defects	Not applicable	Routine	R
4	Good	Min Relevancy	Acceptable, functioning as intended but maintenance required	Not required before next principal inspection.	5 yrs. or >	4
3	Fair		Functioning as intended. Minor to	Preventative maintenance required	< 3 yrs.	3

			more extensive rehab required to upgrade to new	within specified period.		
2	Poor		Unacceptable. Not functioning as intended. Major rehabilitation required	Work required within specified period.	< 2 yrs.	2
1	Very Poor	Max Relevancy	Immediate action. Collapse e imminent.	Danger to users - immediate repair required.	ASAP	1

Deficiency Mapping: Significant deficiencies shall mapped and identified:

- Deficiencies that the inspector determines to be significant (e.g. cracks) shall be field marked (with a numbered field tags supplied by the Contractor), dated and tabulated in a spread sheet. Information on the characteristics of the deficiency shall be included (e.g. the depth, width, and length of each crack).
- Significant deficiencies shall be mapped on scaled drawings showing the locations of the deficiencies to permit future monitoring.

Reporting: A detailed close proximity inspection report for each bridge inspected, should include:

- A summary of all findings on current bridge condition and maintenance items as well as the overall condition of the structure.
- Photographs of the structure and any damage or repairs. Pertinent notes shall be made to highlight conditions noted in the field.
- Identification of any problems noted during the inspection and associated remedial recommendations to maintain or repair the item, including:
 - i. an assessment of the extent of defects and categorized urgency of repairs for each,
 - ii. a list of materials or components required to complete the repairs and a description of special procedures that may be required to complete repairs,
 - iii. a cost estimate for the remedial recommendations is required, and
 - iv. a priority basis for repairs based upon the importance and urgency to the overall infrastructure system
- A five-year maintenance program including cost estimates,
- The appropriate load rating for the structure,
- A recommendation and rationale for the next close proximity inspection.
- A recommended replacement date to maintain current load rating and the maximum life span for the structure for safe public use (i.e. remaining life expectancy).
- A current replacement value for the structure

- Draft reports to be submitted to the Municipality for review and comment prior to the submission of final reports.
- The final and approved inspection reports, including notes, pictures and diagrams. Reports are to be submitted to the Municipality as follows:
 - i. One (1) paper copy of each final report, and
 - ii. One (1) digital copy (flash drive).
- Finally, the Contractor shall submit a brief summary report listing a summary overview of all structures inspected.

Sign and Seal: Each inspection report is to be signed and sealed by a Professional Engineer licensed to work as a Professional Engineer by the Association of Professional Engineers and Geoscientists of British Columbia.

SCHEDULE B – DRAFT AGREEMENT

PROFESSIONAL SERVICES AGREEMENT

THIS AGREEMENT dated for reference **August 15, 2017**

BETWEEN:

VILLAGE OF LIONS BAY, a municipality duly incorporated under the laws of British Columbia and having an address at 400 Centre Road, Lions Bay, BC, V0N 2E0 (the "Municipality").

AND:

[NAME OF FIRM], an engineering firm having an address at 123 Address, City, BC, Postal Code (the "Contractor").

WHEREAS the Municipality wishes to engage the Contractor to provide Services in connection with the provision of close proximity bridge inspections, reports and load ratings on the Municipality's bridges.

THEREFORE in consideration of the payment of one (\$1.00) dollar and other good and valuable consideration paid by each of the parties to the other (the receipt and sufficiency of which is hereby acknowledged) the Municipality and the Contractor agree as follows:

1. DEFINITIONS AND INTERPRETATION**1.1 Definitions**

In these General Terms and Conditions:

- (a) "Agreement" means this Agreement and all appendices attached hereto;
- (b) "Municipality" means the Village of Lions Bay;
- (c) "Contractor" means the Contractor who is providing Services under this Agreement;
- (d) "Disbursements" means the actual out-of-pocket costs and expenses as identified in Appendix 2 (or Appendix 3 if applicable), which the Contractor incurs in providing the Services;
- (e) "Fees" means the price set out in Appendix 2 (or Appendix 3 if applicable) for the provision of the Services, unless otherwise agreed by the parties in writing, and includes all taxes;

- (f) "Indemnitees" means the Municipality and all of its elected and appointed officials, officers, employees, servants, representatives, and agents;
- (g) "Proposal" means the Contractor's Proposal attached as Appendix 2;
- (h) "RFP" means the Request for Proposals number RFP.17.10;
- (i) "Services" means the services as described generally in Appendix 1, including anything and everything required to be done for the fulfilment and completion of this Agreement; and
- (j) "Term" has the meaning described in Section 3.1

1.2 Agreement

This Agreement may be modified only by express and specific written agreement. In the event of a conflict between the provisions of any documents listed below, then the following documents shall govern and take precedence in the following order:

- (a) this Agreement;
- (b) Addenda;
- (c) the RFP;
- (d) the Proposal; and
- (e) other terms, if any, that are agreed to by the parties in writing.

1.3 Appendices

The following attached Appendices are part of this Agreement:

Appendix 1 – Scope of Services;

Appendix 2 – Contractor's Proposal;

Appendix 3 –Special Terms and Conditions and Negotiated Changes (if applicable)

2. SERVICES

2.1 Services

The Contractor covenants and agrees with the Municipality to provide the Services as described generally in Appendix 1, including anything and everything required to be done for the fulfillment and completion of this Agreement (the "**Services**"). The Services provided will meet the specifications and scope set out in Schedule A of the RFP and the Proposal.

2.2 Changes to Services

The Municipality may from time to time, by written notice to the Contractor, make changes in the scope of the Services. The terms of this Agreement will apply to any change in the Services, and the Fees for the changed Services, and the time for the Contractor's performance, will generally correspond to the Fees and time of performance as described in Appendix 2. The Contractor will not provide any additional Services in excess of the scope of Services requested in writing by the Municipality.

2.3 Standard of Care

The Contractor will perform the Services with that degree of care, skill and diligence normally provided by a qualified and experienced practitioner performing services similar to the Services, and on the understanding that the Municipality is relying on the Contractor's experience and expertise. The Contractor represents that it has the expertise, qualifications, resources, and relevant experience to provide the Services.

2.4 Inspection and Acceptance

All Services performed under this Agreement may be subject to inspection and verification by the Municipality. The Contractor shall provide the Municipality with copies of all documentation deemed necessary by the Municipality for efficient expediting. The Municipality will notify the Contractor in writing of its rejection of any Services which are not in accordance with the description or specifications stipulated in this Agreement and the Contractor shall forthwith rectify all such defects at its own expense and be held liable for any and all expenses or losses resulting from such defect. No acceptance by, or on behalf of, the Municipality shall release the Contractor of its obligations as further stated hereunder.

2.5 Holdback for deficient Services

The Municipality may hold back from payments otherwise due to the Contractor up to 200% of a reasonable estimate, as determined by the Municipality, on account of deficient Services. This holdback may be held, without interest, until such deficiency or defect is remedied.

2.6 Completion

Completion of the Services shall be made free and clear of all liens and encumbrances within the time, in the manner, and to the destination stipulated in this Agreement. In the event of failure to meet this condition, the Municipality shall be entitled to the return of

all monies paid by the Municipality on account of this Agreement and, in addition, may cancel this Agreement without liability or penalty and the Contractor shall be held liable for any and all expenses or losses resulting from such failure.

2.7 Patents

The Contractor warrants and guarantees that Services delivered under this Agreement do not infringe any valid patent, industrial design, copyright or trademark, foreign or domestic, owned or controlled by any other corporation, firm or person, and agrees to indemnify and save harmless the Municipality and all of its elected and appointed officials, officers, employees, servants, representatives and agents, from and against any and all claims, demands, causes of action, suits, losses, damages and costs, liabilities, expenses and judgments (including all actual legal costs) by reason of any claim, action or litigation arising out of any alleged or actual infringement of any patent, copyright or trademark, foreign or domestic, relating to the use or sale of any Services supplied under this Agreement.

3. TERM

3.1 Commencement Date and Term

The Contractor shall provide the Services for the period commencing on [INSERT START DATE] and terminating on [INSERT END DATE] (the "Term").

3.2 Term May Be Extended

The parties may extend the Term by mutual agreement. If the Term is extended, the provisions of this Agreement will remain in force except where amended in writing by the parties.

3.3 Time

The Contractor acknowledges that time is of the essence with respect to the provision of the Services and accordingly the Contractor will provide the Services within the performance or completion dates or time periods (the "Time Schedule") as set out in Appendix 2, or as otherwise agreed to in writing by the Municipality and the Contractor. If at any time the Contractor discovers that the Time Schedule cannot be met it will immediately advise the Municipality in writing and provide a revised Time Schedule. If the Contractor is delayed by an action or omission of the Municipality, then the Term will be extended for such reasonable time as agreed between the parties.

4. PERSONNEL

4.1 Qualified Personnel

The Contractor will provide only personnel who have the qualifications, experience and capabilities to perform the Services.

4.2 Listed Personnel and Sub-Contractors

The Contractor will perform the Services using the personnel and sub-contractors as may be listed in the Proposal and the Contractor will not remove any such listed personnel or sub-contractors from the provision of the Services without the prior written approval of the Municipality.

4.3 Replacement of Personnel or Sub-Contractors

If the Municipality reasonably objects to the performance, qualifications, experience or suitability of any of the Contractor's personnel or sub-contractors then the Contractor will, on written request from the Municipality, replace such personnel or sub-contractors.

4.4 Sub-Contractors and Assignment

Except as provided for in this Agreement, the Contractor will not engage any personnel or sub-contractors, or sub-contract or assign its obligations under this Agreement, in whole or in part, without the prior written approval of the Municipality.

4.5 Agreements with Sub-Contractors

The Contractor will preserve and protect the rights of the Municipality with respect to any Services performed under sub-contract and incorporate the terms and conditions of this Agreement into all sub-contracts as necessary to preserve the rights of the Municipality under this Agreement. The Contractor will be as fully responsible to the Municipality for acts and omissions of sub-contractors and of persons directly or indirectly employed by them as for acts and omissions of persons directly employed by the Contractor.

5. LIMITED AUTHORITY

5.1 Agent of Municipality

The Contractor is not and this Agreement does not render the Contractor an agent or employee of the Municipality, and without limiting the above, the Contractor does not

have authority to enter into any contract or reach any agreement on behalf of the Municipality, except for the limited purposes as may be expressly set out in this Agreement, or as necessary in order to provide the Services. The Contractor will make such lack of authority clear to all persons with whom the Contractor deals in the course of providing the Services.

5.2 Independent Contractor

The Contractor is an independent contractor. This Agreement does not create the relationship of employer and employee, a partnership, or a joint venture. The Municipality will not control or direct the details, means or process by which the Contractor provides the Services. The Contractor will determine the number of days and hours of work required to properly and completely provide the Services. The Contractor is primarily responsible for provision of the Services and may not delegate or assign the provision of any Services to any other person except as provided for in this Agreement. The Contractor will be solely liable for the wages, benefits, work schedules and work conditions of any partners, employees or sub-contractors.

6. FEES

6.1 Fees And Disbursements

The Municipality will pay to the Contractor the Fees and Disbursements in accordance with this Agreement. Payment by the Municipality of the Fees and Disbursements will be full payment for the Services and the Contractor will not be entitled to receive any additional payment without the prior written approval of the Municipality.

6.2 Costs included in Fees and Disbursements

For greater certainty, costs of general management, non-technical supporting services, general overhead, mobilization/demobilization, travel and all other items associated with the Services are deemed to be covered by the Fees and Disbursements and will not be subject to additional payment by the Municipality.

6.3 No increase in Fees and Disbursements without Written Agreement

No increases in Fees and Disbursements will be accepted by the Municipality without prior written acceptance by the Municipality.

6.4 Payment

Subject to any contrary provisions set out in this Agreement:

- (a) the Contractor will submit a monthly invoice (the “**Invoice**”) to the Municipality requesting payment of the portion of the Fees and Disbursements relating to the Services provided in the previous month and including the following information:
- an invoice number;
 - the Contractor's name, address and telephone number;
 - the Municipality's reference number for the Services: to be provided on execution of a signed contract;
 - the names, charge-out rates and number of hours worked in the previous month of all employees of the Contractor and any sub-contractors that have performed Services during the previous month;
 - the percentage of Services completed at the end of the previous month;
 - the total budget for the Services and the amount of the budget expended to the date of the Invoice;
 - taxes (if any); and
 - grand total of the Invoice;
- (b) the Contractor will on request from the Municipality provide receipts and invoices for all Disbursements claimed;
- (c) if the Municipality reasonably determines that any portion of an Invoice is not payable, then the Municipality will so advise the Contractor;
- (d) the Municipality will pay the portion of an Invoice which the Municipality determines is payable within 30 days of the receipt of the Invoice less any deductions for setoffs or holdbacks permitted by this Agreement, except the Municipality may hold back from payments 10% of the amount the Municipality determines is payable to the Contractor until such time as the Municipality gives final approval of completion of work;
- (e) if the Contractor offers the Municipality a cash discount for early payment, then the Municipality may, at the Municipality’s sole discretion, pay the portion of an Invoice which the Municipality determines is payable at any time after receipt of the Invoice;
- (f) Invoices will be submitted by the Contractor by mail to:
- (g) Accounts Payable Department
- (h) Village of Lions Bay

- (i) PO Box 141, 400 Centre Road, Lions Bay, BC V0N 2E0;
- (j) the payment by the Municipality of any invoice will not bind the Municipality with respect to any subsequent payment or final payment and will not mean that the Municipality has accepted Services that are not in accordance with the requirements of this Agreement, or that the Contractor is in any manner released from its obligation to comply with this Agreement; and
- (k) unless otherwise provided, all dollar amounts referred to in this Agreement are in lawful money of Canada.

6.5 Records

The Contractor will prepare and maintain proper records related to the Services, including records, receipts and invoices relating to Disbursements. On request from the Municipality, the Contractor will make the records available open to audit examination by the Municipality at any time during regular business hours during the time the Contractor is providing the Services and for a period of six years after the Services are complete. This right to audit shall include sub-contractors to the Contractor. The Contractor shall ensure the Municipality has this right to audit with all sub-contractors.

6.6 Non-Residents

If the Contractor is a non-resident of Canada and does not provide to the Municipality a waiver of regulation letter, the Municipality will withhold and remit to the appropriate governmental authority the greater of:

- (a) 15% of each payment due to the Contractor; or
- (b) the amount required under applicable tax legislation.

7. MUNICIPALITY'S RESPONSIBILITIES

7.1 Municipal Information

The Municipality will, in co-operation with the Contractor, make efforts to make available to the Contractor information, surveys, and reports which the Municipality has in its files and records that relate to the Services. The Contractor will review any such material upon which the Contractor intends to rely and take reasonable steps to determine if that information is complete or accurate. The Contractor will assume all risks that the information is complete and accurate and the Contractor will advise the Municipality in writing if in the Contractor's judgment the information is deficient or unreliable and undertake such new surveys and investigations as are necessary.

7.2 Municipal Decisions

The Municipality will in a timely manner make all decisions required under this Agreement, examine documents submitted by the Contractor and respond to all requests for approval made by the Contractor pursuant to this Agreement.

7.3 Notice of Defect

If the Municipality observes or otherwise becomes aware of any fault in the Services, it may notify the Contractor, but nothing in this Agreement will be interpreted as giving the Municipality the obligation to review the Contractor's performance of the Services.

8. INDEMNITY, INSURANCE, DAMAGES AND LICENCING

8.1 Indemnity

The Contractor will indemnify and save harmless the Municipality and all of its elected and appointed officials, officers, employees, servants, representatives and agents (collectively the “**Indemnitees**”), from and against all claims, demands, causes of action, suits, losses, damages and costs, liabilities, expenses and judgments (including all actual legal costs) for damage to or destruction or loss of property, including loss of use, and injury to or death of any person or persons which any of the Indemnitees incur, suffer or are put to arising out of or in connection with any failure, breach or non-performance by the Contractor of any obligation of this Agreement, or any wrongful or negligent act or omission of the Contractor or any employee or agent of the Contractor.

8.2 Survival of Indemnity

The indemnity described in section 8.1 will survive the termination or completion of this Agreement and, notwithstanding such termination or completion, will continue in full force and effect for the benefit of the Indemnitees.

8.3 Contractor's Insurance Policies

The Contractor will, without limiting its obligations or liabilities and at its own expense, provide and maintain throughout this Agreement the following insurances in forms and amounts acceptable to the Municipality from insurers licensed to conduct business in Canada:

- (a) commercial general liability insurance on an occurrence basis, in an amount not less than five million (\$5,000,000) dollars inclusive per occurrence against death, bodily

injury and property damage arising directly or indirectly out of the work or operations of the Contractor, its employees and agents. The insurance will include cross liability and severability of interests such that the coverage shall apply in the same manner and to the same extent as though a separate policy had been issued to each insured. The insurance will include, but not be limited to: premises and operators liability, broad form products and completed operations, owners and Contractors protective liability, blanket contractual, employees as additional insureds, broad form property damage, non-owned automobile, contingent employers liability and broad form loss of use and personal injury, and the Municipality will be added as an additional insured;

- (b) automobile liability insurance on all vehicles owned, operated or licensed in the name of the Contractor in an amount not less than five million (\$5,000,000) dollars per occurrence for bodily injury, death and damage to property;
- (c) professional errors and omissions liability insurance, in an amount not less than two million (\$2,000,000) dollars; and
- (d) Contractors' equipment insurance in an all risks form covering construction machinery and equipment used for the performance of the Services.

8.4 Insurance Requirements

The Contractor will provide the Municipality with evidence of the required insurance prior to the commencement of this Agreement. Such evidence will be in the form of a completed certificate of insurance acceptable to the Municipality. The Contractor will, on request from the Municipality, provide certified copies of all of the Contractor's insurance policies providing coverage relating to the Services, including without limitation any professional liability insurance policies. All required insurance will be endorsed to provide the Municipality with thirty (30) days advance written notice of cancellation or material change restricting coverage. To the extent the Municipality has an insurable interest; the builder's risk policy will have the Municipality as first loss payee. The Contractor will be responsible for deductible amounts under the insurance policies. All of the Contractor's insurance policies will be primary and not require the sharing of any loss by the Municipality or any insurer of the Municipality.

8.5 Contractor Responsibilities

The Contractor acknowledges that any requirements by the Municipality as to the amount of coverage under any policy of insurance will not constitute a representation by the Municipality that the amount required is adequate and the Contractor acknowledges and agrees that the Contractor is solely responsible for obtaining and maintaining policies of

insurance in adequate amounts. The insurance policy coverage limits shall not be construed as relieving the Contractor from responsibility for any amounts which may exceed these limits, for which the Contractor may be legally liable.

8.6 Additional Insurance

The Contractor shall place and maintain, or cause any of its sub-contractors to place and maintain, such other insurance or amendments to the foregoing policies as the Municipality may reasonably direct.

8.7 Waiver of Subrogation

The Contractor hereby waives all rights of recourse against the Municipality for loss or damage to the Contractor's property.

8.8 Protection of Property

The Contractor shall protect Municipality's property and adjacent properties from damage that may arise as the result of the Contractor's operations under the Agreement. Any such damage caused by the Contractor shall be made good by the Contractor at the Contractor's expense.

8.9 WorkSafe BC And Occupational Health And Safety

The Contractor agrees that:

- (a) it will, at its own expense, procure and carry full WorkSafe BC coverage for itself and all workers, employees, servants and others engaged in the supply of the Services;
- (b) the Municipality has the unfettered right to set off the amount of the unpaid premiums and assessments for the WorkSafe BC coverage against any monies owing by the Municipality to the Contractor and the Municipality will have the right to withhold payment under this Agreement until the WorkSafe BC premiums, assessments or penalties in respect of the Services have been paid in full;
- (c) it will provide the Municipality with the Contractor's WorkSafe BC registration number and a letter from the WorkSafe BC confirming that the Contractor is registered in good standing;
- (d) it is the prime contractor for the Services for the purposes of the *Workers Compensation Act*, it will have a safety program in place that meets the requirements of the WorkSafe BC Occupational Health and Safety Regulation and the *Workers Compensation Act*, as prime contractor, the Contractor will be

responsible for appointing a qualified coordinator for insuring the health and safety activities for the location of the Services and that person will be the person so identified in Schedule C, of the Proposal, and the Contractor will advise the Municipality immediately in writing if the name or contact number of the qualified coordinator changes;

- (e) without limiting the generality of any other indemnities granted by the Contractor in this Agreement, the Contractor will indemnify and save harmless the Indemnitees from and against all claims, demands, causes of action, suits, losses, damages, costs, liabilities, expenses, judgments, penalties and proceedings (including all actual legal costs) which any of the Indemnitees incur, suffer or are put to arising out of or in any way related to unpaid WorkSafe BC assessments owing from any person or corporation engaged in the performance of this Agreement or arising out of or in any way related to the failure to observe safety rules, regulations and practices of WorkSafe BC, including penalties levied by WorkSafe BC;
- (f) it will ensure compliance with and conform to all health and safety laws, by-laws or regulations of the Province of British Columbia, including without limitation the *Workers Compensation Act* and Regulations pursuant thereto;
- (g) the Municipality may, on 24 hours written notice to the Contractor, install devices or rectify any conditions creating an immediate hazard existing that would be likely to result in injury to any person; however, in no case will the Municipality be responsible for ascertaining or discovering, through inspections or review of the operations of the Contractor or otherwise, any deficiency or immediate hazard; and
- (h) it understands and undertakes to comply with all the WorkSafe BC Occupational Health and Safety Regulations for hazardous materials and substances, and in particular with the "Workplace Hazardous Materials Information System (WHMIS)" Regulations.

9. TERMINATION

9.1 By the Municipality

The Municipality may at any time and for any reason by written notice to the Contractor terminate this Agreement before the completion of the provision of all Services, such notice to be determined by the Municipality at its sole discretion. Upon receipt of such notice, the Contractor will provide no further Services other than what is reasonably required to terminate the supply of Services and return the Municipality's property to the Municipality. Despite any other provision of this Agreement, if the Municipality terminates

this Agreement before the completion of providing all the Services, the Municipality will pay to the Contractor all amounts owing under this Agreement for Services provided by the Contractor up to and including the date of termination, plus reasonable termination costs in the amount as determined by the Municipality in its sole discretion. Upon payment of such amounts no other or additional payment will be owed by the Municipality to the Contractor, and, for certainty, no amount will be owing on account of lost profits relating to the portion of the Services not supplied or other profit opportunities.

9.2 Termination for Cause

The Municipality may terminate this Agreement for cause as follows:

- (a) if the Contractor is adjudged bankrupt, or makes a general assignment for the benefit of creditors because of its insolvency, or if a receiver is appointed because of its insolvency, the Municipality may, without prejudice to any other right or remedy the Municipality may have, terminate this Agreement by giving the Contractor or receiver or trustee in bankruptcy written notice; or
- (b) if the Contractor is in breach of any term or condition of this Agreement, and such breach is not remedied to the reasonable satisfaction of the Municipality within five days after delivery of written notice from the Municipality to the Contractor, then the Municipality may, without prejudice to any other right or remedy the Municipality may have, terminate this Agreement by giving the Contractor further written notice.

If the Municipality terminates this Agreement as provided by this Section, then the Municipality may:

- (c) enter into contracts, as it in its sole discretion sees fit, with other persons to complete the Services;
- (d) withhold payment of any amount owing to the Contractor under this Agreement for the Services;
- (e) set-off the total cost of completing the Services incurred by the Municipality against any amounts owing to the Contractor under this Agreement, and at the completion of the provision of Services pay to the Contractor any balance remaining; and
- (f) if the total cost to complete the provision of Services exceeds the amount owing to the Contractor, charge the Contractor the balance, which amount the Contractor will forthwith pay.

9.3 Curing Defaults

If the Contractor is in default of any of its obligations under this Agreement, then the Municipality may without terminating this Agreement, upon five days written notice to the Contractor, remedy the default and set-off all costs and expenses of such remedy against any amounts owing to the Contractor. Nothing in this Agreement will be interpreted or construed to mean that the Municipality has any duty or obligation to remedy any default of the Contractor.

10. COMPLIANCE WITH LAWS

10.1 Applicable Laws

This Agreement shall be governed by and construed in accordance with the laws and statutes of the Province of British Columbia, regulations or bylaws. The Municipality and the Contractor accept the jurisdiction of the courts of British Columbia and agree that any action under this Agreement shall be brought in such courts and that any reference to any statute, regulation or bylaw refers to that enactment as it may be amended or replaced from time to time.

10.2 Compliance with Applicable Laws

The Contractor will provide the Services in full compliance with all applicable federal, provincial and municipal enactments and regulations.

10.3 Interpretation of Enactments

The Contractor will, as a qualified and experienced contractor, interpret enactments and regulations applicable to the provision of the Services. If an authority having jurisdiction imposes an interpretation which the Contractor could not reasonably have verified or foreseen prior to entering into this Agreement, then the Municipality will pay the additional costs, if any, of making alterations so as to conform to the required interpretation.

11. CONFIDENTIALITY, DISCLOSURE OF INFORMATION AND WORK PRODUCT

11.1 No Disclosure

Except as provided for by law or otherwise by this Agreement, the Contractor will keep strictly confidential any information supplied to, obtained by, or which comes to the

knowledge of the Contractor as a result of the performance of the Services and this Agreement, and will not, without the prior express written consent of the Municipality, publish, release, disclose or permit to be disclosed any such information to any person or corporation, either before, during or after termination of this Agreement, except as reasonably required to complete the Services.

11.2 Freedom of Information and Protection of Privacy Act

The Contractor acknowledges that the Municipality is subject to the *Freedom of Information and Protection of Privacy Act* of British Columbia and agrees to any disclosure of information by the Municipality required by law.

11.3 Return of Property

The Contractor agrees to return to the Municipality all of the Municipality's property at the completion of this Agreement, including any and all copies or originals of reports provided by the Municipality.

11.4 Use of Work Product

The Contractor hereby sells, assigns and transfers to the Municipality the right, title and interest required for the Municipality to use and receive the benefit of all the reports, drawings, plans, designs, models, specifications, computer software, concepts, products, designs or processes or other such work product produced by or resulting from the Services rendered by the Contractor.

12. DISPUTE RESOLUTION

12.1 Dispute Resolution Procedures

The parties will make reasonable efforts to resolve any dispute, claim, or controversy arising out of this Agreement or related to this Agreement ("**Dispute**") using the dispute resolution procedures set out in this section 12.1 as follows:

- (a) the parties will make reasonable efforts to resolve any Dispute by amicable negotiations and will provide frank, candid and timely disclosure of all relevant facts, information and documents to facilitate negotiations;
- (b) If all or any portion of a Dispute cannot be resolved by good faith negotiations within 30 days, either party may by notice to the other party refer the matter to mediation. Within seven days of delivery of the notice, the parties will mutually appoint a mediator. If the parties fail to agree on the appointment of the mediator,

then either party may apply to the British Columbia International Commercial Arbitration Centre for appointment of a mediator. The parties will continue to negotiate in good faith to resolve the Dispute with the assistance of the mediator. The place of mediation will be Lions Bay, British Columbia, or such other place as the Municipality may, in its sole discretion, specify. Each party will equally bear the costs of the mediator and other out-of-pocket costs, and each party will bear its own costs of participating in the mediation; and

- (c) If within 90 days of the request for mediation, the Dispute is not settled, or if the mediator advises that there is no reasonable possibility of the parties reaching a negotiated resolution, then the parties may mutually agree to submit the Dispute to binding arbitration in accordance with the rules of the British Columbia International Commercial Arbitration Centre, or either party may, without further notice, commence litigation.

13. MUNICIPAL POWERS

13.1 Powers Preserved

Nothing in this Agreement limits or abrogates, or will be deemed to limit or abrogate, the jurisdiction of the Council of the Municipality in the exercise of its powers, rights or obligations under any public or private statute, regulation or by-law or other enactment.

13.2 No financial commitments beyond current fiscal year

The Contractor recognizes and agrees that the Municipality cannot make financial commitments beyond the Municipality's current fiscal year. The Municipality will annually make good faith requests for appropriation of sufficient funds to cover all payments covered by this Agreement. If Municipality Council does not appropriate funds, or appropriates insufficient funds, the Municipality will notify the Contractor of its intention to terminate or reduce the services so affected within 30 days after the non-appropriation becomes final. Such termination shall take effect 30 days from the date of notification, shall not constitute an event of default and shall relieve the Municipality, its officers and employees, from any responsibility or liability for the payment of any further amounts under this Agreement.

14. GENERAL

14.1 Entire Agreement

This Agreement, including the Appendices and any other documents expressly included by reference in this Agreement, contains the entire agreement of the parties regarding the provision of the Services, and no understandings or agreements, oral or otherwise, exist between the parties except as expressly set out in this Agreement. This Agreement supersedes and cancels all previous agreements between the parties relating to the Services. In the event that the Contractor issues an invoice, packing slip, sales receipt, or any like document to the Municipality, the Municipality accepts the document on the express condition that any terms and conditions in it which constitute terms and conditions which are in addition to or which establish conflicting terms and conditions to those set out in this Agreement are expressly rejected by the Municipality.

14.2 Amendment

This Agreement may be amended only by agreement in writing, signed by both parties.

14.3 Merger And Survival

The representations, agreements, covenants and obligations set out in this Agreement shall survive the performance of the Services and payment of the Fees and Disbursements.

14.4 Unenforceability

If any provision of this Agreement is invalid or unenforceable, it will be severed from the Agreement and will not affect the enforceability or validity of the remaining provisions of the Agreement.

14.5 Cumulative Remedies

The Municipality's remedies under this Agreement are cumulative and in addition to any right or remedy which may be available to the Municipality at law or in equity.

14.6 Notices

Any notice, report or other document that either party may be required or may wish to give to the other must be in writing, unless otherwise expressly provided for, and will be deemed to be validly given to and received by the addressee:

- (a) by hand, on delivery;

- (b) by facsimile or email, by acknowledgement; or
- (c) by mail, five calendar days after posting.

The addresses for delivery will be as shown in the Proposal.

14.7 Headings

The headings in this Agreement are inserted for convenience of reference only and will not form part of nor affect the interpretation of this Agreement.

14.8 Assignment

This Agreement may not be assigned in whole or in part by the Contractor without the prior written consent of the Municipality.

14.9 Singular, Plural and Gender

Wherever the singular, plural, masculine, feminine or neuter is used throughout this Agreement the same will be construed as meaning the singular, plural, masculine, feminine, neuter or body corporate where the context so requires.

14.10 Waiver

Any failure of the Municipality at any time or from time to time to enforce or require the strict keeping or performance of any of the terms and conditions contained in this Agreement shall not constitute a waiver of the terms and conditions and shall not affect or impair the terms or conditions in any way or the Municipality's right at any time to avail itself of any remedies as the Municipality may have for any breach of the terms and conditions.

14.11 Counterparts

This Agreement may be executed in one or more counterparts all of which when taken together will constitute one and the same Agreement, and one or more of the counterparts may be delivered by fax transmission or as a PDF file by email or as a hard copy.

14.12 Enurement

This Agreement shall enure to the benefit of and be binding upon the respective successors and permitted assigns of the Municipality and the Contractor.

END OF PAGE

WHEREFORE, the parties have executed this Agreement on the dates indicated below:

VILLAGE OF LIONS BAY by its authorized signatories:

c/s

Mayor

Corporate Officer:

Date executed: _____, 2017.

[INSERT CONTRACTORS LEGAL NAME] by its authorized signatories:

[Name of Signatory]

[Name of Signatory]

Date executed: _____, 2017.

APPENDIX 1 –SERVICES

The Services shall consist of all Services described in this Agreement, the RFP and the Proposal (as amended by Appendix 3 if applicable) and shall include the following:

Services

Access: All of these bridge inspections will require the use of some specialized equipment to access all of the bridge components, and proposals should clearly identify the methodology to ensure all girders and beams will be viewed and inspected at close proximity. The Contractor shall include supply of all equipment necessary to provide access to all parts of the bridge and specialized equipment required to assess the bridge condition. The Contractor must also determine the best method to safely and thoroughly inspect and field mark deficiencies on all the identified components.

Traffic Control: It will be the Contractor's responsibility to provide traffic control notifications and implement all traffic control procedures required. Traffic delays must be kept to a minimum and where possible, single lane alternating traffic must be provided for. Traffic delays exceeding 30 minutes will need to be scheduled with Municipal staff to ensure appropriate public communication takes place.

Inspection Schedule: At least ten days prior to the contract commencement, the Contractor shall submit the final inspection schedule to the Municipality for review. This schedule shall include the structure number, the inspection date and the approximate time of all activities.

Communication: The Contractor's proposal shall also identify a communications protocol for the notification of serious deficiencies found during field inspections.

Existing Documentation: The Municipality will provide what documentation it has to the successful Contractor. The Contractor will review drawings, documents, and previous reports PRIOR to commencement of fieldwork.

Non-Destructive Testing (NDT): Advanced NDT is not anticipated at this time; however, the Contractor's proposal may include unit pricing for NDT as an option for each bridge. In some cases, cursory testing procedures will be required during the inspection to better evaluate the condition of particular structural elements. These includes hammer sounding of timber and concrete elements to identify possible timber rot; concrete delamination; and wire-brushing of corroded steel elements to measure section loss.

Individual Material Testing: Based on the results of the visual evaluation, additional tests may be required to gain a more in-depth understanding on the performance of the structures. Thus, the successful proponent shall provide unit prices or hourly rates, inclusive of disbursements and travelling, for the following tests:

- Timber Drilling Tests on wood structures
- Loading Rating Analysis
- Concrete delamination survey (chain drag)
- Concrete coring including strength, air void analysis, chlorite ion content, and PH
- Ultra-sonic impact test
- Half-cell testing

Load ratings: The results of load ratings must include a summary detailing the rationale for any factors used and contain calculations, in a clear logical format. Load ratings shall be calculated using current code requirements.

Inspection Process Criteria: The procedure of inspection is primarily based on the recording and rating of observed structural defects identified during a thorough examination of the structure. The following methodology shall be used in the inspection:

- Inventory photographs shall be taken of the structure to show the general configuration, site conditions, and other such background information not necessarily relating to defective components of the bridge. Inventory photographs are normally used during subsequent inquiries for evaluation of site conditions.
- In a methodical step-by-step approach, all elements of the structure shall be inspected at close proximity (preferably within one metre), evaluated, and rated.
- A condition rating shall be given for each element. If a defect exists, then the percentage rating of the element affected is given a reduced rating. The rating system will require the inspector to account for the effect of the defect on functionality and relevance to the structural integrity of the structure. The rating system to used is summarized in the following table:

Rating "R"		Structural integrity and safety of user	Functionality - secondary to structural integrity. Does it perform as originally designed?	Maintenance priority and urgency of repair	Urgency "U"	
					Monitor	M
5	Excellent	No Defects	New Condition - No Defects	Not applicable	Routine	R
4	Good	Minimum Relevancy	Functioning as intended but maintenance required	Not required before next principal inspection.	5 yrs. or >	4
3	Fair		Functioning as intended but minor to more extensive rehab required	Preventative maintenance required within specified period.	< 3 yrs.	3
2	Poor		Unacceptable. Not functioning as intended and major rehab required	Work required within specified period.	< 2 yrs.	2
1	Very Poor	Maximum Relevancy	Immediate action. Collapse imminent.	Danger to users - immediate repair required.	ASAP	1

Deficiency Mapping: Significant deficiencies shall be mapped and identified:

- Deficiencies that the inspector determines to be significant (e.g. cracks) shall be field marked (with a numbered field tags supplied by the Contractor), dated and tabulated in a spread sheet. Information on the characteristics of deficiencies shall be included (e.g. the depth, width, and length of each crack).
- Significant deficiencies shall be mapped on scaled drawings showing the locations of the deficiencies to permit future monitoring.

Reporting: A detailed close proximity inspection report for each bridge inspected, should include:

- A summary of all findings on current bridge condition and maintenance items as well as the overall condition of the structure.
- Photographs of the structure and any damage or repairs. Pertinent notes shall be made to highlight conditions noted in the field.
- Identification of any problems noted during the inspection and associated remedial recommendations to maintain or repair the item, including:
 - i. an assessment of the extent of defects and categorizes urgency of repairs for each,
 - ii. a list of materials or components required to complete the repairs and a description of special procedures that may be required to complete repairs,
 - iii. a cost estimate for the remedial recommendations is required, and
 - iv. a priority basis for repairs based upon the importance and urgency to the overall infrastructure system
- A five-year maintenance program including cost estimates,
- The appropriate load rating for the structure,
- A recommendation and rationale for the next close proximity inspection.
- A recommended replacement date to maintain current load rating and the maximum life span for the structure for safe public use (i.e. remaining life expectancy).
- A current replacement value for the structure
- Draft reports are to be submitted for review and comment prior to the submission of final reports.
- The final and approved inspection reports should include notes, pictures and diagrams. Reports are to be submitted to the Municipality as follows:
 - i. One (1) paper copies of each final report, and
 - ii. One (1) digital copy (flash drive).
- Finally, the Contractor shall submit a brief summary report listing a summary overview of all structures inspected.

Sign and Seal: Each inspection report is to be signed and sealed by a Professional Engineer licensed to work as a Professional Engineer by the Association of Professional Engineers and Geoscientists of British Columbia.

APPENDIX 2 – PROPOSAL

[INSERT COPY OF PROPOSAL]

APPENDIX 3 – SPECIAL TERMS AND CONDITIONS AND NEGOTIATED CHANGES

[INSERT ANY SPECIAL TERMS AND CONDITIONS AND/OR NEGOTIATED CHANGES TO RFP, PROPOSAL AND THIS AGREEMENT].

SCHEDULE C – FORM OF PROPOSAL

Schedule C0 – Proponent Information

Attach Schedule C to the front of your proposal

RFP Project Title: Close Proximity Bridge Inspections, Reports and Load Ratings

RFP Reference Number: RFP.17.10

Legal Name of Proponent:

Contact Person and Title:

GST Number:

WorkSafe Number:

Health & Safety Coordinator:

Business Address:

Telephone:

Fax:

Email Address:

To the Village of Lions Bay,

- 1.0 **I/We, the undersigned duly authorized representative of the Proponent**, having received and carefully reviewed all of the Proposal documents, including the RFP and any issued addenda posted on the BC Bid Website (or having received directly), and having full knowledge of the Site, and having fully informed ourselves as to the intent, difficulties, facilities and local conditions attendant to performing the Services, submit this Proposal in response to the RFP.
- 2.0 **I/We confirm** that the following schedules are attached to and form a part of this Proposal:
 - 2.1 Schedule C-0 – Proponent Information;
 - 2.2 Schedule C-1 – Exceptions and Departures;
 - 2.3 Schedule C-2 – Questionnaire;
 - 2.4 Schedule C-3 – Pricing Proposal

- 3.0 **I/We confirm** that this proposal is accurate and true to best of my/our knowledge.
- 4.0 **I/We confirm** that, if I/we am/are awarded the Agreement, I/we will at all times be the “prime contractor” as provided by the Worker's Compensation Act (British Columbia) with respect to the Services. I/we further confirm that if I/we become aware that another contractor at the place(s) of the Services has been designated as the “prime contractor”, I/we will notify the Municipality immediately, and I/we will indemnify and hold the Municipality harmless against any claims, demands, losses, damages, costs, liabilities or expenses suffered by the Municipality in connection with any failure to so notify the Municipality.
- 5.0 **I/We confirm** that by submitting a proposal and signing below, the undersigned declares that the owners and officers of the Proponent have no relationship with any employee, elected official, or committee member of the Municipality, or any other relationship or circumstance which could be perceived to be a conflict of interest, unless such relationship or circumstance is fully disclosed and attached to this form.

This Proposal is submitted this _____ day of _____, 20__.

I/We have the authority to sign on behalf of the Proponent.

(Name of Proponent)

(Signature of Authorized Signatory)

(Signature of Authorized Signatory)

(Print Name and Position of Authorized Signatory)

(Print Name and Position of Authorized Signatory)

Schedule C1 – Exceptions and Departures

If the Proponent takes exception to any of the requirements, terms or conditions contained in the RFP Documents please identify all such exceptions here. Proponents may add additional lines to the table below if required.

Reference should be made in each case to the relevant provision(s) of the RFP Documents to which the exception applies and, to the extent possible, Proponent should submit the wording it would propose.

Note: Exceptions not identified and submitted below may not be considered at a later date.

As of the date of this proposal, we advise that we have the ability to meet all of the above requirements except as follows (list in order of priority, if any):

Section Reference	Exception Description	Rationale	Proposed Wording

I/We offer the following alternates to improve the Services described in the RFP (list, if any):

Section	Requested Departure(s) / Alternative(s)

The Proponent acknowledges that the departures it has requested in Schedule C 1 will not form part of the Contract unless and until the Municipality agrees to them in writing by initialing or otherwise specifically consenting in writing to be bound by any of them.

Schedule C2 – Questionnaire

Proponents should respond to the questions under each heading clearly and concisely.

Through the information provided in your Proposal, the Municipality expects to gain an in-depth understanding of a Proponent's experience, capabilities, and capacity to provide the Services outlined in Schedule A, Scope of Services. The answers to the following questions may be taken directly from your proposal.

PROFILE, EXPERIENCE AND QUALIFICATIONS:

Q1: Describe the location of branches, background, years of business under the current legal entity, stability and structure of the Proponent. Provide an executive summary describing the Proponent's relevant experience and qualifications in delivering Services similar to those required by the RFP.

A1:

Q2: Describe three (3) specific examples of recent work completed by the Proponent that required the performance of services similar to the Services described in this RFP (to the extent possible). In each case, the Proponent should identify:

- Project and client name;
- Scope of services provided;
- Project actual start and completion dates;
- Names of key personnel involved in the project who will be available to perform the Services under the Agreement; and
- Contact reference information, phone number and email address of an individual from each client who can provide details and feedback regarding the services performed by the Proponent. The Municipality may contact these references.

A2:

Q3: Provide information on the background and experience of all key personnel proposed to undertake the Services including any subcontractors:

A3:

TECHNICAL; APPROACH AND METHODOLOGY

Q4: Provide a narrative that illustrates an understanding of the Municipality's requirements and Services:

A4:

Q5: Provide a description of the general approach and methodology that the Proponent would take in performing and managing the Services and accomplishing the objectives within the Municipality's schedule:

A5:

Schedule C3 – Pricing Proposal

Indicate the Proponent's proposed Fee (excluding GST), and the basis of calculation (use the spaces provided and/or attach additional pages, if necessary) as follows:

Item No.	Unit Pricing
1. Lions Bay Avenue over Harvey Creek	
2. Isleview Place over Alberta Creek (Lower)	
3. Isleview Place over Alberta Creek (Upper)	
4. Cross Creek Road over Harvey Creek	
5. Bayview Road over Alberta Creek	
6. Bayview Road (Driveway Access) over Alberta Creek	
7. Bayview Place over Alberta Creek	
8. Lions Bay Avenue over Alberta Creek (Driveway Access)	
Disbursements:	
Contingency Allowance*:	
Subtotal (Net Price):	
GST:	
TOTAL PROPOSAL PRICE (including taxes):	

** Payment of the Contingency Allowance or portions thereof will only be made in the event the Municipality authorizes additional work, in which case the amount of the payment will be determined as specified. Any unused portion will be deducted from the price.*

Additional Expenses (if applicable):

The proposed Agreement attached as Schedule "B" to the RFP provides that expenses are to be included within the Fee, other than the expenses listed in the Contract as disbursements. Details of disbursements are to be shown in the chart above. Please indicate any expenses that would be payable in addition to the proposed Fee and proposed disbursements set out above:



The Municipality of the Village of Lions Bay

REQUEST FOR PROPOSAL (RFP)

RFP.17.10

For

CLOSE PROXIMITY BRIDGE INSPECTIONS,
REPORTS AND LOAD RATINGS

Village-owned Bridges

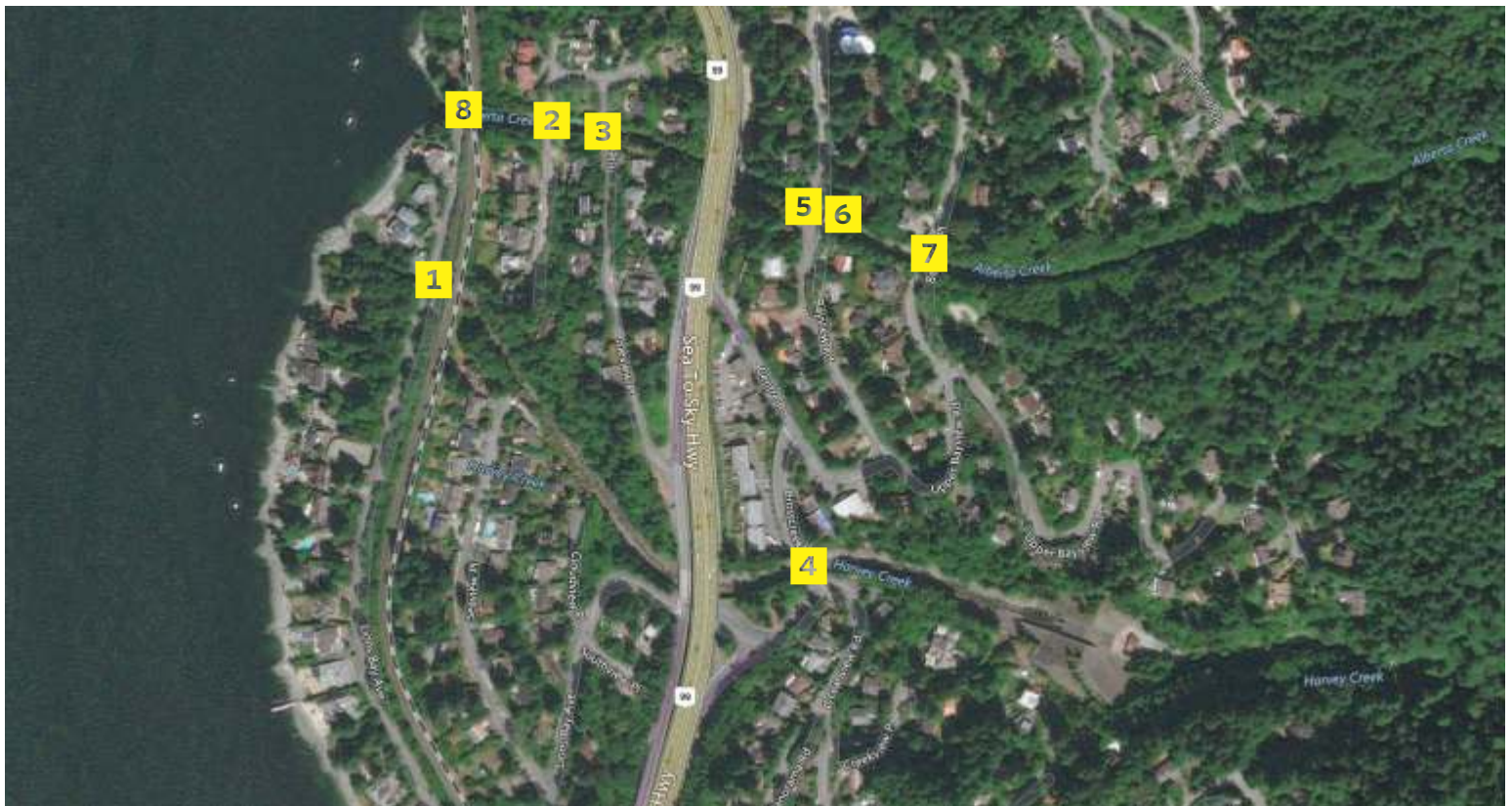

Appendix A

Detailed Inspection Findings

Bridge 01

General Information

Bridge Reference	Bridge 01 – Lions Bay Avenue over Harvey Creek
Inspection Date / Time	2015-09-21 @ 11:40 a.m.
Inspector(s)	Asnee Pochanart – AECOM & Neil Marcus – AECOM
Basic Description	Three-span Concrete Bridge (long central span with two short end spans) Single Traffic Lane with concrete curb and wooden railing on each side Concrete curbs – Approx. 170 W x 280 H (sloped face) 4 deck drains through curbs each side Guardrails – L127x127 steel angle vertical posts, horizontal wood railing. Top of guardrail 1.24m above deck Large pipes both sides of bridge, hung below deck
Superstructure Type(s)	Cast-in place concrete deck on two cast-in-place concrete (longitudinal) beams
Substructure Type(s)	Cast in place transverse beam on cast-in-place concrete column (each pier). No abutment visible. End cross beam appears to sit on rock wall
Length x Width	18.90m Long x 6.10m Wide (0.17 curb + 0.075 offset+ 5.60 lane + 0.075 offset + 0.17 curb)
Observations	-
Remarks	-

Issues Summary

Issue	Resolution	Approx. Cost	Monitoring
Very High (Resolve <1yr)			
-	-	-	
High (Resolve <5yr)			
Joints between end of bridge and approach roadway need to be re-sealed	Remove vegetation and dirt. Seal the joints.	\$1,500	
Crack and spall of interior deck underside near west longitudinal beam (about 3.0 m south of north column)	Remove spalled concrete. Clean and patch.	\$2,000	
Crack and spall of interior deck underside above south face of north column	Remove spalled concrete. Clean and patch.	\$2,000	
Minor decay – horizontal members of wooden railing		-	Check the railing condition (annually)
Medium (Resolve <10yr)			
-	-	-	

Bridge 02

General Information

Bridge Reference	Bridge 02 – Isleview Place over Alberta Creek (Lower Bridge)
Inspection Date / Time	2015-09-21 @ 11:10 a.m.
Inspector(s)	Asnee Pochanart – AECOM & Neil Harcus – AECOM
Basic Description	Single Span Concrete Bridge Single Traffic Lane with Pedestrian sidewalk on east side and wide curb west side Standard MOT 4-Rail barrier on each side
Superstructure Type(s)	Cast-in place concrete deck (or topping), curb and sidewalk on precast concrete box girders
Substructure Type(s)	Cast in place abutments (both ends) Mechanically Stabilized Earth (MSE) wing-walls (both ends) – Precast Concrete Panel Type
Length x Width	18.15m Long x 6.40m Wide (0.85 curb + 3.60 lane + 1.95 sidewalk)
Observations	Pipe hung from underside of sidewalk east side, unable to view west side. No visible cracks in deck Railing south-west end damaged, otherwise railing in good shape
Remarks	-

Issues Summary

Issue	Resolution	Approx. Cost	Monitoring
Very High (Resolve <1yr)			
Tripping hazard due to unevenness between bridge sidewalk and sidewalk approaches	Regrade (asphalt) sidewalk approaches	\$1,500	-
High (Resolve <5yr)			
Vegetation growing into abutment seats (at both abutments) with potential of growing into girder underside longitudinal joints	Remove vegetation	\$1,000	-
Vegetation overgrowing ends of bridge and barriers with potential of growing (or having its roots growing) into the joints between abutment and MSE wing-walls or between MSE wall facial panels	Remove vegetation	\$1,000	-
Cracked approach pavement and broken edge of bridge deck near northwest corner	Seal the crack, patch, or remove (& rebuild) the cracked portion and its adjacent areas. Remove and patch the broken deck edge. Seal the joint	\$1,500	-
Vegetation growing in joints both ends of deck	Remove vegetation and dirt. Seal the joints.	\$1,000	-
Medium (Resolve <10yr)			
Series of transverse cracks (differential shrinkage cracks) on the sidewalk and curb undersides	Locate the cracks on the top of sidewalk and curb. Seal the cracks.	\$3,000	-

Bridge 03

General Information

Bridge Reference	Bridge 03 – Isleview Place over Alberta Creek (Upper Bridge)
Inspection Date / Time	2015-09-21 @ 11:30 a.m.
Inspector(s)	Asnee Pochanart – AECOM & Neil Harcus – AECOM
Basic Description	Single Span Concrete Bridge Single Traffic Lane with Pedestrian sidewalk on east side and wide curb west side Standard MOT 4-Rail barrier on each side
Superstructure Type(s)	Cast-in place concrete deck (or topping), curb and sidewalk on precast concrete box girders
Substructure Type(s)	Cast in place abutments (both ends) Mechanically Stabilized Earth (MSE) wing-walls (both ends) – Precast Concrete Panel Type
Length x Width	18.15m Long x 6.40m Wide (0.85 curb + 3.60 lane + 1.95 sidewalk)
Observations	No visible cracks in deck. Railing in good shape
Remarks	<i>Unable to determine if there were any pipes under the deck. Expect transverse cracks (differential shrinkage cracks) along sidewalk and curb undersides. Expect Vegetation growing into abutment seats (similar to the nearby Bridge 02)</i>

Issues Summary

Issue	Resolution	Approx. Cost	Monitoring
Very High (Resolve <1yr)			
Tripping hazard due to unevenness between bridge sidewalk and sidewalk approaches	Regrade (asphalt) sidewalk approaches	\$1,500	
High (Resolve <5yr)			
Vegetation growing into abutment seats (at both abutments) with potential of growing into girder underside longitudinal joints	Remove vegetation	\$1,000	
Vegetation overgrowing ends of bridge and barriers with potential of growing (or having its roots growing) into the joints between abutment and MSE wing-walls or between MSE wall facial panels	Remove vegetation	\$1,000	
Cracked approach pavement near edge of bridge deck at northwest corner and southwest corner	Seal the crack, patch, or remove (& rebuild) the cracked portion and its adjacent areas. Remove and patch the broken deck edge. Seal the joint	\$3,000	
Vegetation growing in joints both ends of deck	Remove vegetation and dirt. Seal the joints.	\$1,000	
Medium (Resolve <10yr)			
Series of transverse cracks (differential shrinkage cracks) on the sidewalk and curb undersides	Locate the cracks on the top of sidewalk and curb. Seal the cracks.	\$3,000	

Bridge 04

General Information

Bridge Reference	Bridge 04 – Cross Creek Road over Harvey Creek
Inspection Date / Time	2015-09-21 @ 9:00 a.m.
Inspector(s)	Asnee Pochanart – AECOM & Neil Harcus – AECOM
Basic Description	Single Span Concrete Bridge Two Traffic Lanes with Pedestrian sidewalk on east side and west side Standard MOT 4-Rail barrier on each side
Superstructure Type(s)	Cast-in place concrete deck (or topping), curb and sidewalk on precast concrete box girders
Substructure Type(s)	Cast in place abutments (both ends) Cast-in-place retaining wall (Northwest corner)
Length x Width	20.00m Long x 11.35m Wide (0.85 curb + 2 x 3.70 lane + 1.95 sidewalk)
Observations	Railing in good shape. One pipe below deck on the east side
Remarks	<i>Unable to access the two abutments to inspect their conditions. Unable to determine if there were any pipes under the deck on the west side. Expect transverse cracks (differential shrinkage cracks) along sidewalk undersides.</i>

Repair Summary

Issue	Resolution	Approx. Cost	Monitoring
Very High (Resolve <1yr)			
Tripping hazard due to unevenness between bridge sidewalk and sidewalk approaches	Regrade (asphalt) sidewalk approaches	\$3,000	-
High (Resolve <5yr)			
Deck longitudinal cracks (crack width 0.3 mm approx.) full length of bridge, at 1.3 m west of bridge centerline	Clean and seal the cracks	\$2,500	-
Settlement (50 mm) and rotation (30 mm outward) of CIP retaining wall.	-	-	Monitor the settlement and rotation of retaining wall (Annually)
Medium (Resolve <10yr)			
Misalignment of railing due to the wall settlement and rotation. May deteriorate.	Remove and re-install approach railing to align with bridge railing.	\$1,500	Measure the misalignment (Annually)
Maintenance of joints between approach roads and bridge deck	Remove vegetation and dirt. Re-seal the joints.	\$2,000	-
Series of transverse cracks (differential shrinkage cracks) on the sidewalk and curb undersides	Locate the cracks on the top of sidewalks. Seal the cracks.	\$4,000	-

Bridge 05

General Information

Bridge Reference	Bridge 05 – Bayview Road over Alberta Creek
Inspection Date / Time	2015-09-21 @ 10:30 a.m.
Inspector(s)	Asnee Pochanart – AECOM & Neil Harcus – AECOM
Basic Description	Single Span Concrete Bridge Two Traffic Lanes with Pedestrian sidewalk on east side and wide curb west side Standard MOT 4-Rail barrier on each side
Superstructure Type(s)	Cast-in place concrete deck (or topping), curb and sidewalk on precast concrete box girders
Substructure Type(s)	Cast in place abutments (both ends)
Length x Width	18.15m Long x 10.15m Wide (0.85 curb + 2 x 3.60 lane + 1.95 sidewalk)
Observations	Railing in good shape
Remarks	<i>Unable to access the two abutments to inspect their conditions Unable to determine if there were any pipes under the deck Expect transverse cracks (differential shrinkage cracks) along sidewalk and curb undersides Expect Vegetation growing into abutment seats</i>

Issues Summary

Issue	Resolution	Approx. Cost	Monitoring
Very High (Resolve <1yr)			
Tripping hazard due to unevenness between bridge sidewalk and sidewalk approaches	Regrade (asphalt) sidewalk approaches	\$1,500	-
High (Resolve <5yr)			
Vegetation growing into abutment seats (at both abutments) with potential of growing into girder underside longitudinal joints	Remove vegetation	\$1,000	-
Deck longitudinal cracks (crack width 0.3 mm approx.) full length of bridge, one at 1.5 m from east curb and another one at 2.1 m from west sidewalk	Clean and seal the cracks	\$4,000	-
Cracked approach pavement near edge of bridge deck at both ends of the bridge	Seal the crack, patch, or remove (& rebuild) the cracked portion and its adjacent areas. Remove and patch the broken deck edge. Seal the joint	\$3,000	-
Vegetation growing in joints both ends of deck	Remove vegetation and dirt. Seal the joints.	\$1,000	-
Medium (Resolve <10yr)			
Series of transverse cracks (differential shrinkage cracks) on the sidewalk and curb undersides	Locate the cracks on the top of sidewalk and curb. Seal the cracks.	\$3,000	-

Bridge 06

General Information

Bridge Reference	Bridge 06 – Bayview Road (Private Driveway) over Alberta Creek
Inspection Date / Time	2015-09-21 @ 10:00 a.m.
Inspector(s)	Asnee Pochanart – AECOM & Neil Harcus – AECOM
Basic Description	Single Span Bridge – Wooden Deck / Joists on Steel Girders Single Traffic Lane Heavy timber curbs – 300Wx300H on each side Wood guard rails each side. Top of guardrail 1.04m above deck
Superstructure Type(s)	Wooden Deck / Joists on Steel Girders (two steel girders with intermediate and lateral bracing)
Substructure Type(s)	Wooden Bearing Beam on Cast in place Concrete abutment (both ends)
Length x Width	20.00m Long x 3.90m wide (0.30 curb + 3.30 lane + 0.30 curb)
Observations	Corroded steel structure with section loss Timber deck seems to have been replaced or partially replaced (since 2004 inspection)
Remarks	Unknown load carrying capacity This bridge could potentially be rehabilitated (completely or partially.) Subject to a detailed inspection and load evaluation, an option of using precast concrete deck and making steel girder composite (with concrete deck) maybe feasible. The inspection and load evaluation would also determine if the bridge under its current condition (or after partially rehabilitated) would require any (load limit) posting.

Issues Summary

Issue	Repair Task	Repair Cost	Monitoring
Very High (Resolve <1yr)			
Hole in pavement (Northeast Corner)	Clean and repair	\$1,000	-
Safety Improvement (Ref: 2004 Report – Items 1.5) Clearance to overhead wire	Install warning sign and safety mirror	\$3,500	-
High (Resolve <5yr)			
Decayed and cracked bearing beams	Replace bearing beams and anchor bolts	\$20,000	-
Displaced modular block wing-wall (Northeast corner) (Ref: 2004 Report – Item 2.3)	Reconstruction of displaced wing-wall	\$15,000	-
Corrosion of steel girders especially at top and bottom flanges (Ref: 2004 Report – Item 4.3)	Pressure wash. Inspect and quantify section loss. Re-paint	\$20,000	-
Extensive corrosion of secondary members (diaphragms and lateral bracing) (Ref: 2004 Report – Item 4.5)	Pressure wash. Inspect and quantify section loss. Re-paint	\$10,000	-
Vertical railing posts not replaced recently show signs of extensive decay (5 Posts)	Replace railing posts	\$3,000	-
Medium (Resolve <10yr)			
Decayed – timber curb north-west side and horizontal members of wooden guardrail	Replace curbs and guardrails	\$12,000	Check the railing condition (annually)
Timber floor joists show sign of rot and decay	Replace decayed floor joists (removal and reinstallation of deck planks)	\$20,000	Check the condition (annually)
Allowance for another deck replacement	Replace wooden deck	\$30,000	-

Bridge 07

General Information

Bridge Reference	Bridge 07 – Bayview Place over Alberta Creek
Inspection Date / Time	2015-09-21 @ 9:30 a.m.
Inspector(s)	Asnee Pochanart – AECOM & Neil Harcus – AECOM
Basic Description	Single Span Concrete Bridge Single Traffic Lane with Pedestrian sidewalk on east side and wide curb west side Standard MOT 4-Rail barrier on each side
Superstructure Type(s)	Cast-in place concrete deck (or topping), curb and sidewalk on precast concrete box girders
Substructure Type(s)	Cast in place abutments (both ends)
Length x Width	18.15m Long x 6.40m Wide (0.85 curb + 3.60 lane + 1.95 sidewalk)
Observations	No visible cracks in deck Railing in good shape
Remarks	<i>Unable to determine if there were any pipes under the deck</i>

Issues Summary

Issue	Resolution	Approx. Cost	Monitoring
Very High (Resolve <1yr)			
Tripping hazard due to unevenness between bridge sidewalk and sidewalk approaches	Regrade (asphalt) sidewalk approaches	\$1,500	-
Misaligned approach barrier (North end on the curb side)	Align and reconnect the misaligned barrier segment	\$500	-
High (Resolve <5yr)			
Vegetation growing into abutment seats (at both abutments) with potential of growing into girder underside longitudinal joints	Remove vegetation	\$1,000	-
Vegetation overgrowing ends of bridge and barriers	Remove vegetation	\$1,000	-
Vegetation growing in joints both ends of deck	Remove vegetation and dirt. Seal the joints.	\$1,000	-
Medium (Resolve <10yr)			
Series of transverse cracks (differential shrinkage cracks) on the sidewalk and curb undersides	Locate the cracks on the top of sidewalk and curb. Seal the cracks.	\$3,000	-

Bridge 08

General Information

Bridge Reference	Bridge 08 – Lions Bay Avenue over Alberta Creek (Private driveway end of Lions Bay Avenue)
Inspection Date / Time	2015-09-21 @ 12:40 p.m.
Inspector(s)	Asnee Pochanart – AECOM & Neil Harcus – AECOM
Basic Description	Single Span Concrete Bridge Single Traffic Lane with timber curb and wooden guardrail on each side Timber curb = 0.30 m wide x 0.40 m high Top of railing = 1.47 m above deck
Superstructure Type(s)	Cast-in place concrete
Substructure Type(s)	Undetermined (unable to view) type of abutment Concrete wing-wall (Southwest Corner)
Length x Width	14.00 m Long x 4.20m Wide (0.30 curb + 3.60 lane + 0.30 curb)
Observations	No visible cracks in deck
Remarks	<i>Unable to determine if there were any pipes under the deck</i>

Issues Summary

Issue	Resolution	Approx. Cost	Monitoring
Very High (Resolve <1yr)			
Vertical plank missing (west guardrail)	Install the missing plank	\$300	-
High (Resolve <5yr)			
Vegetation encroaching (north end)	Remove vegetation	\$1,000	-
Medium (Resolve <10yr)			
Minor decay – timber curb north-west side, and horizontal members of wooden guardrail	Replace curbs and guardrails	\$8,000	Check the railing condition (annually)

Appendix B

Bridge Sketches

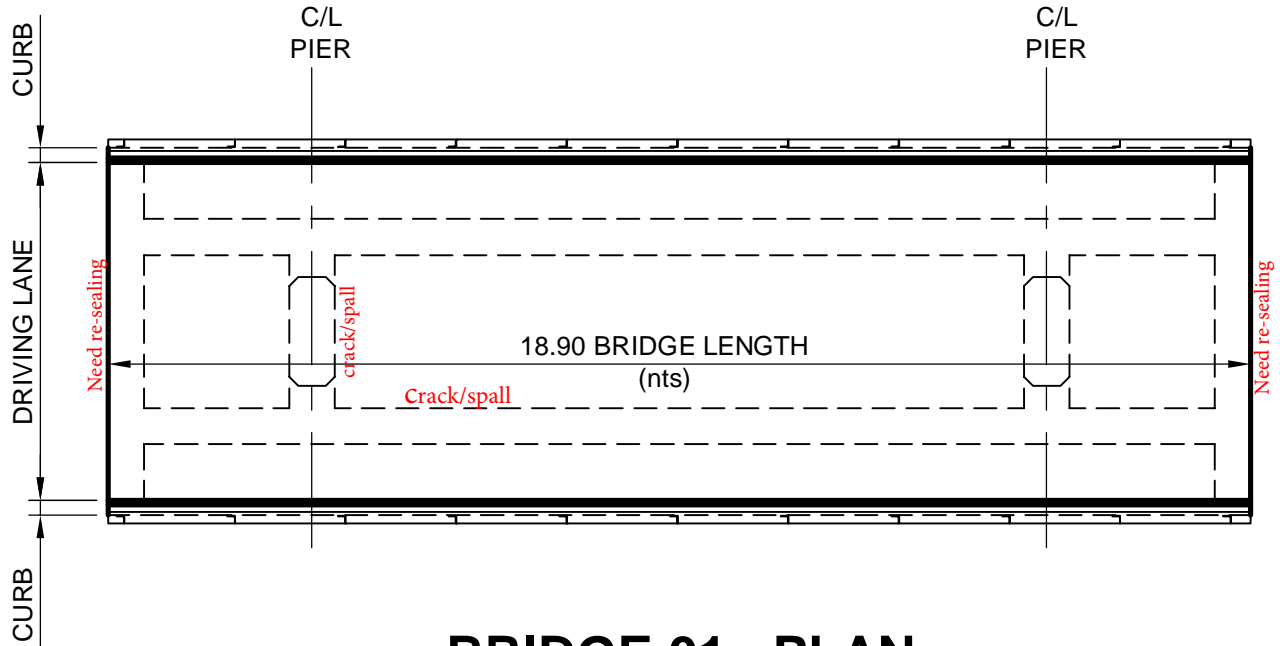

BRIDGE 01 - PLAN

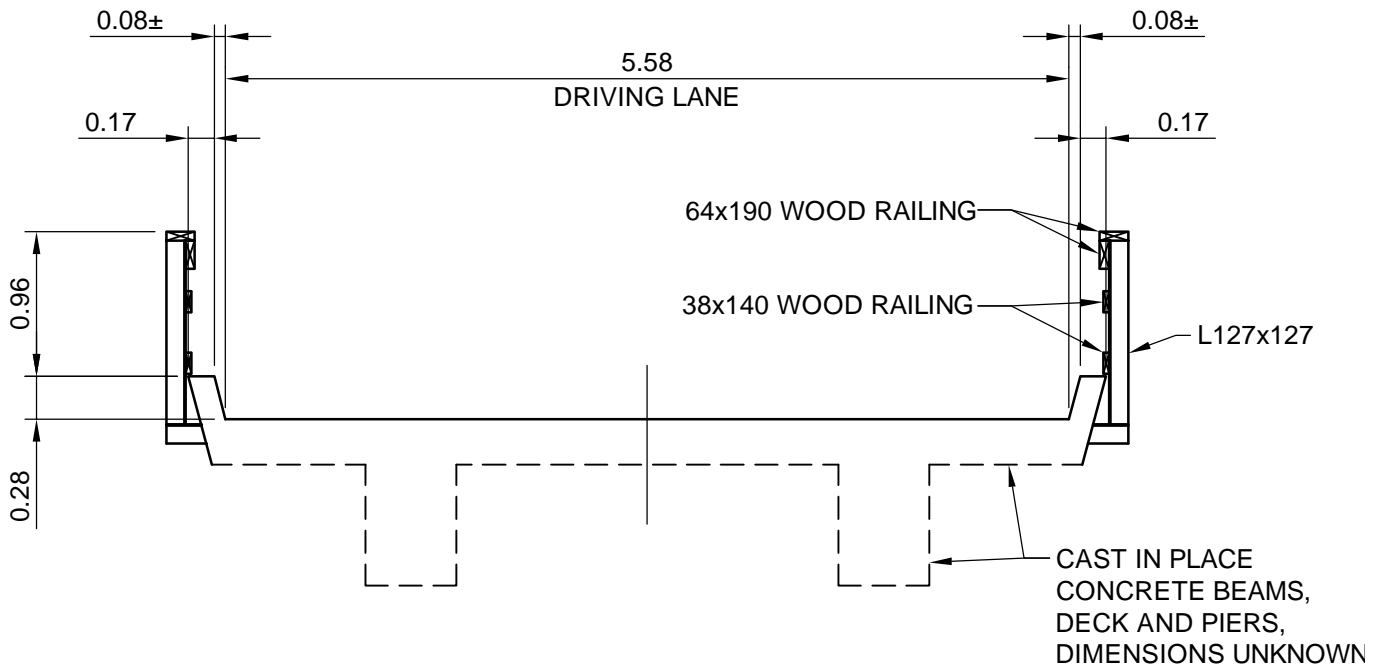

BRIDGE 01 - SECTION

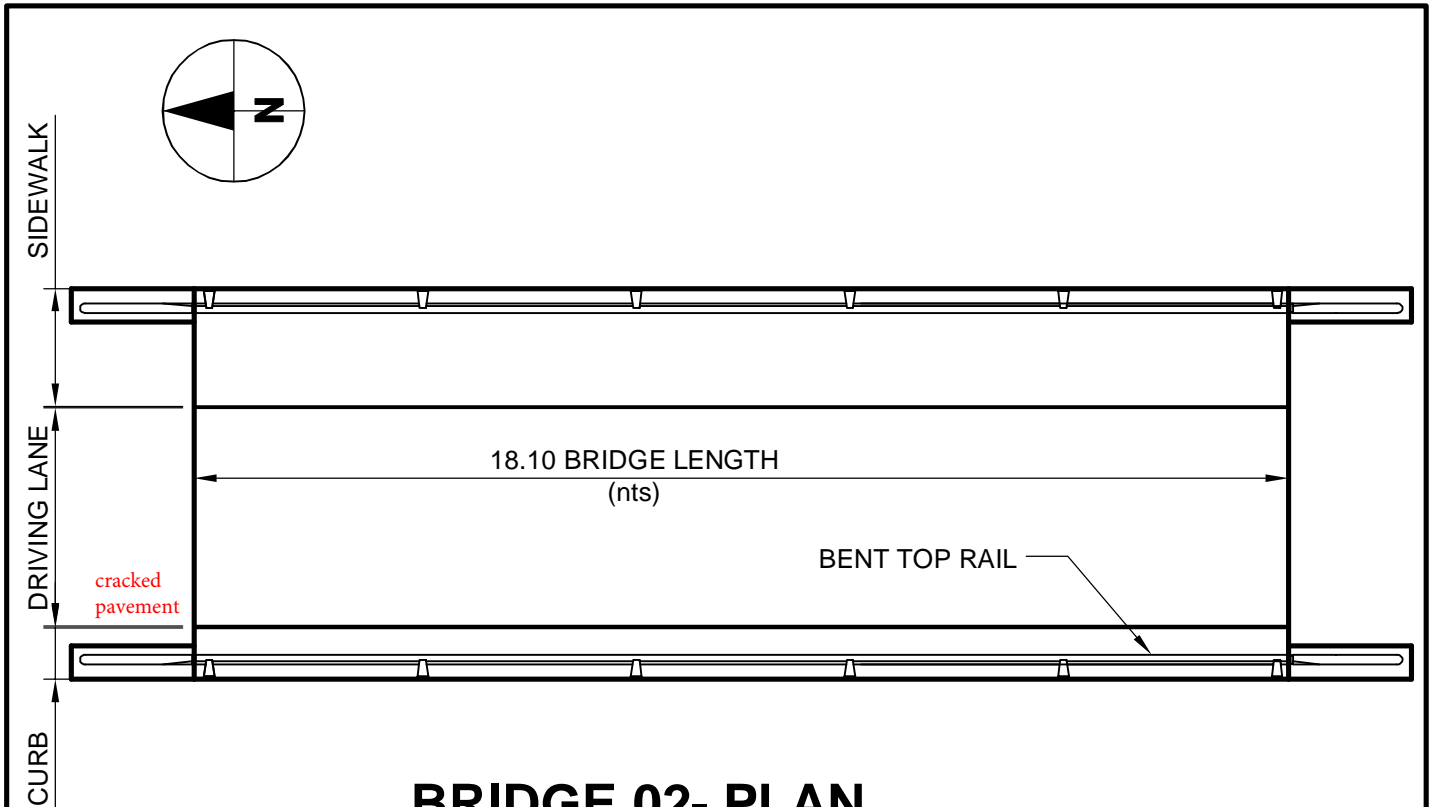

BRIDGE 02- PLAN

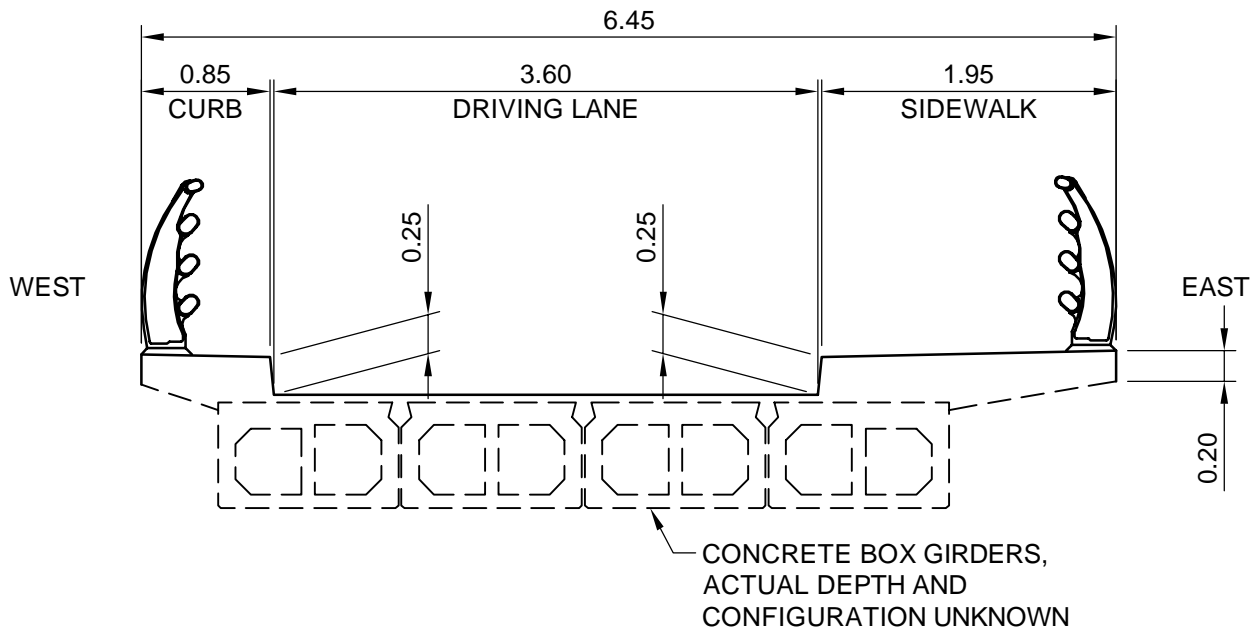

BRIDGE 02 - SECTION

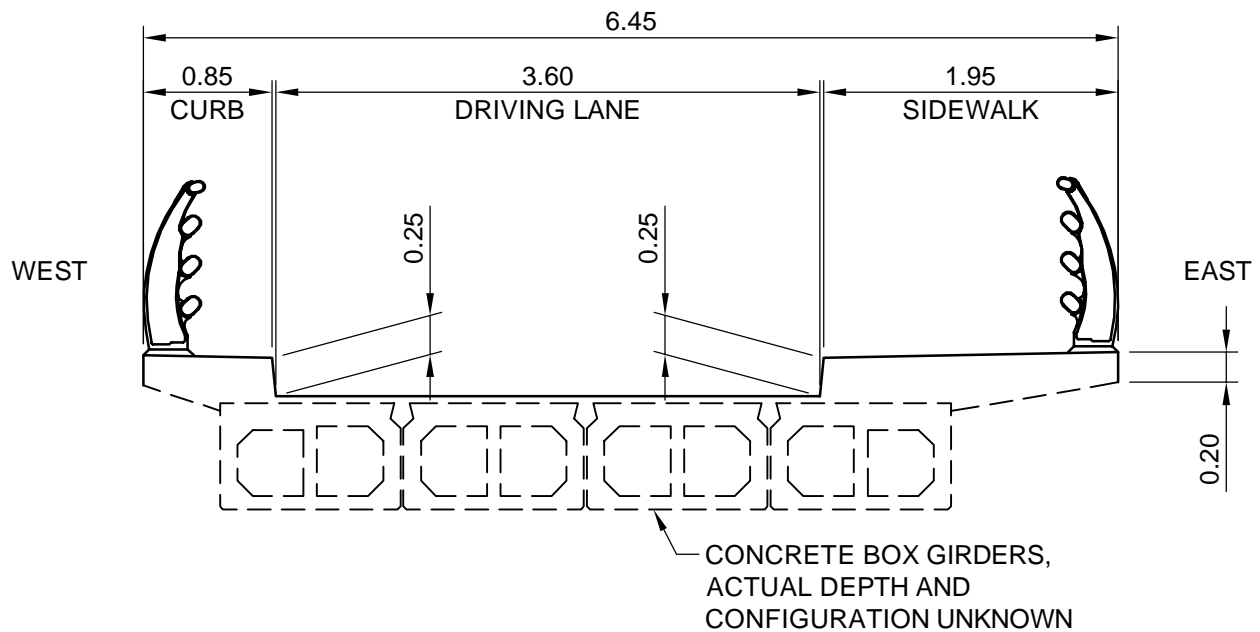
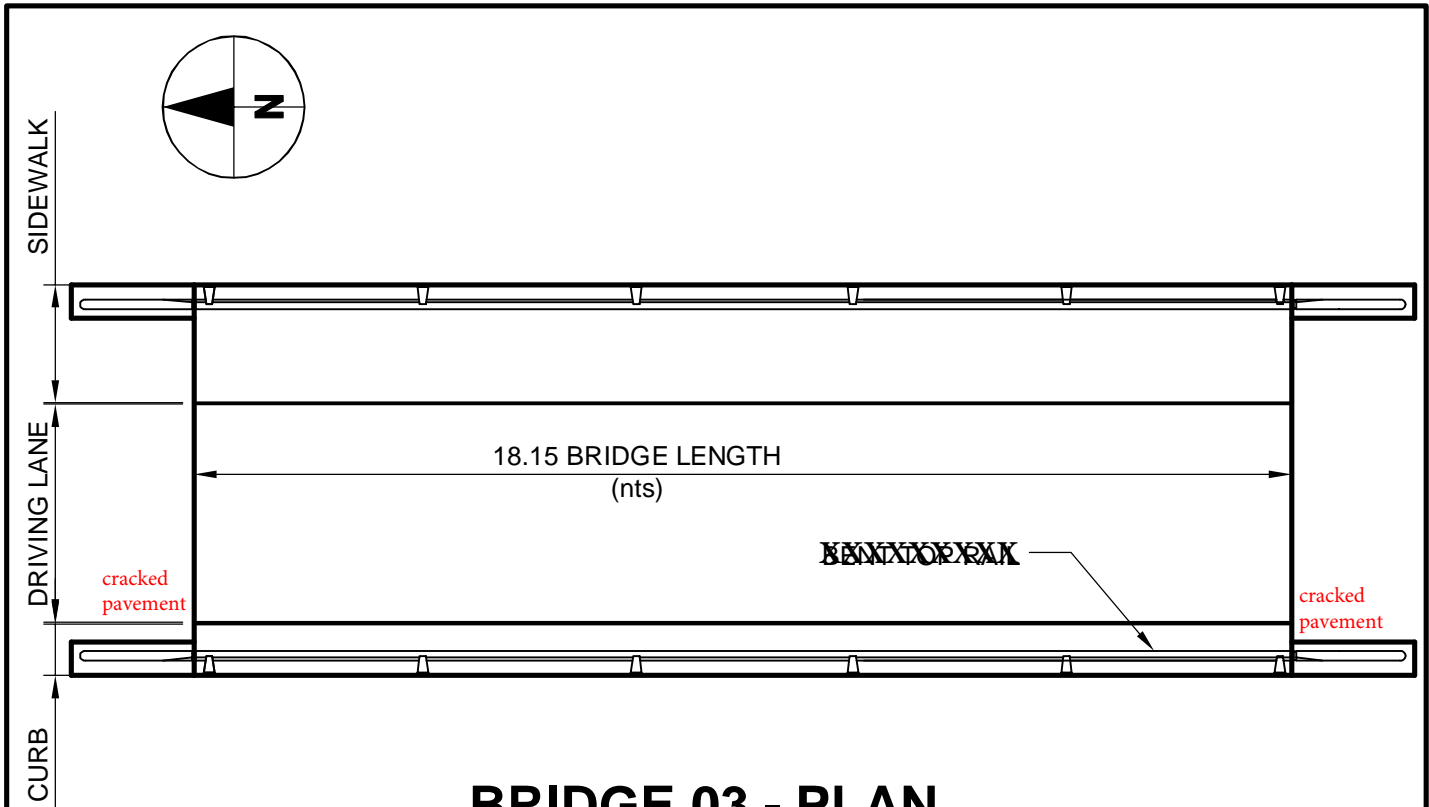

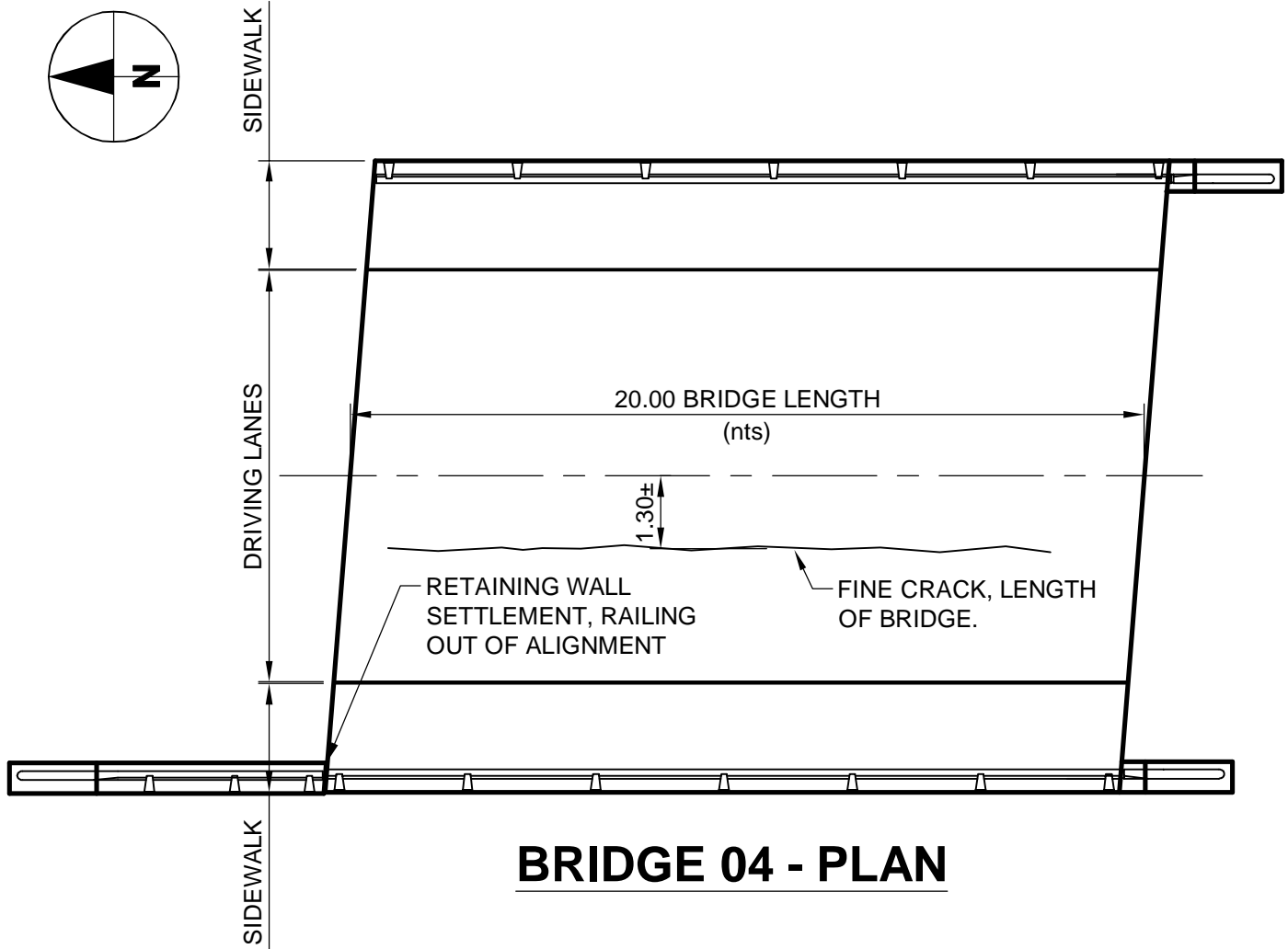
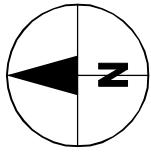

BRIDGE 04 - PLAN

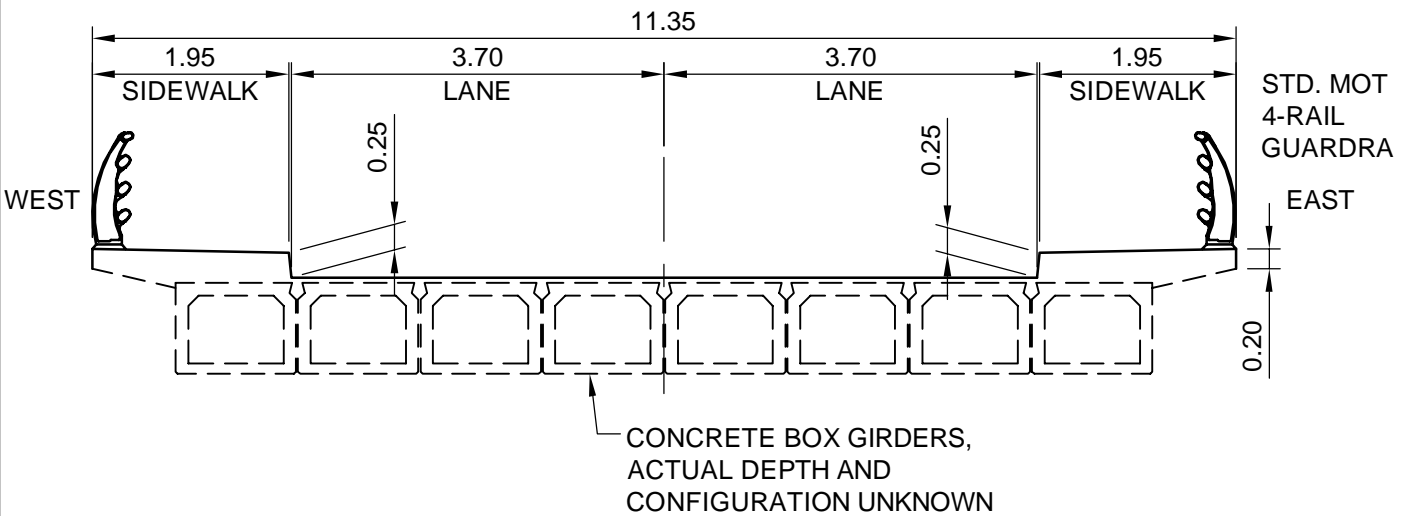

BRIDGE 04 - SECTION

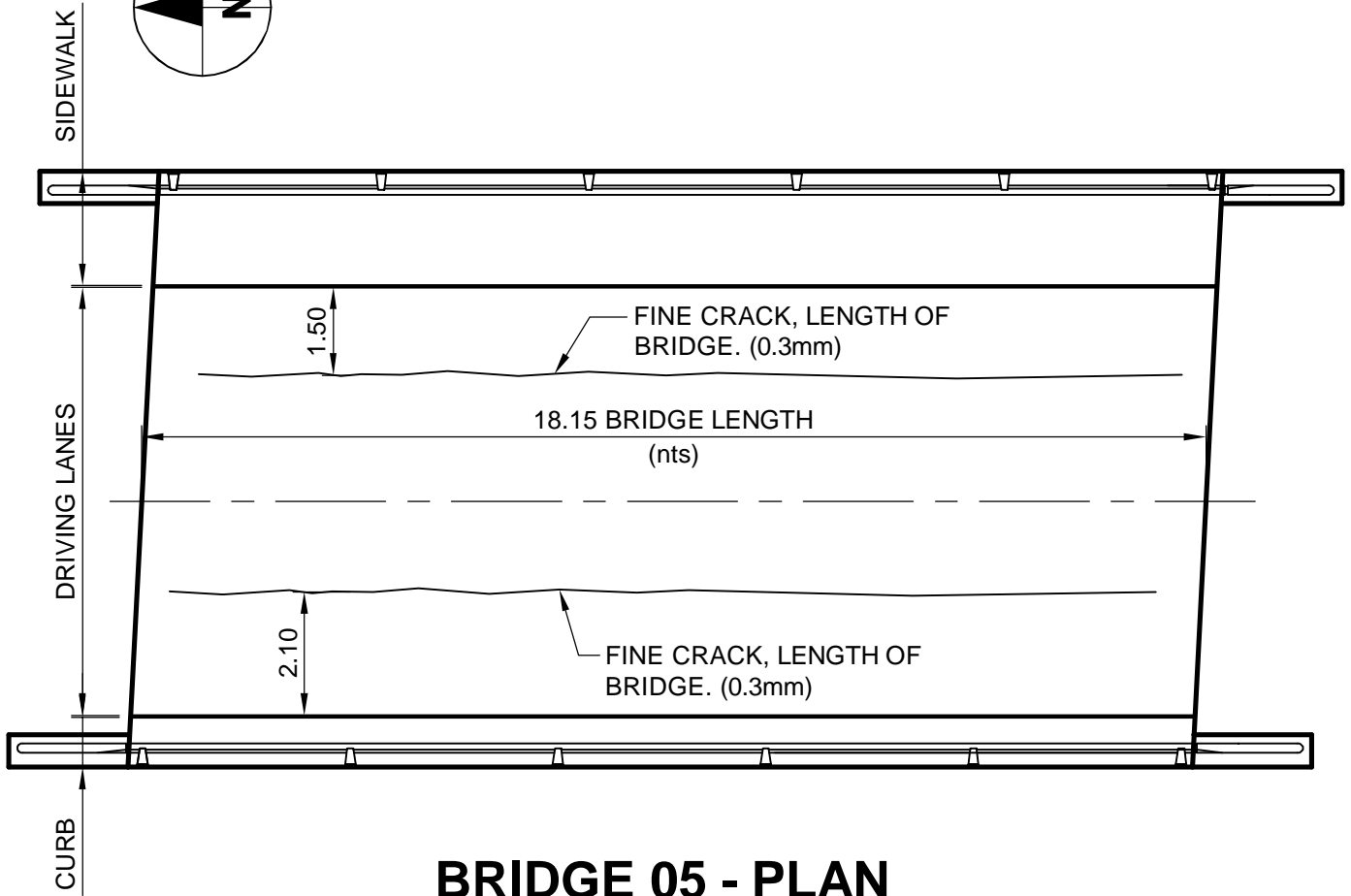
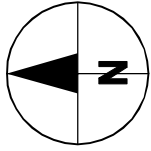

BRIDGE 05 - PLAN

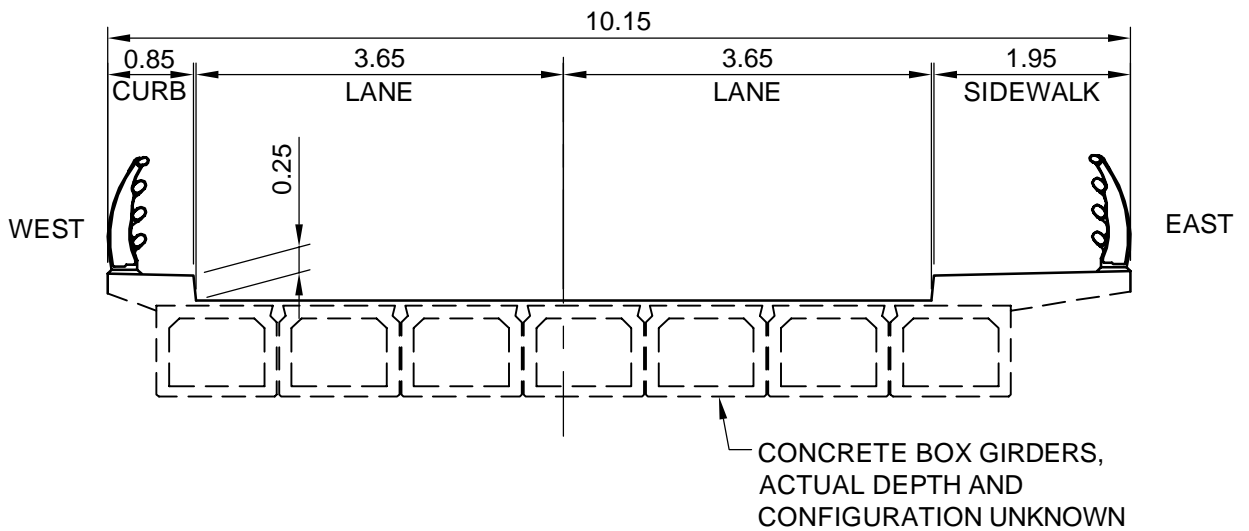

BRIDGE 05 - SECTION

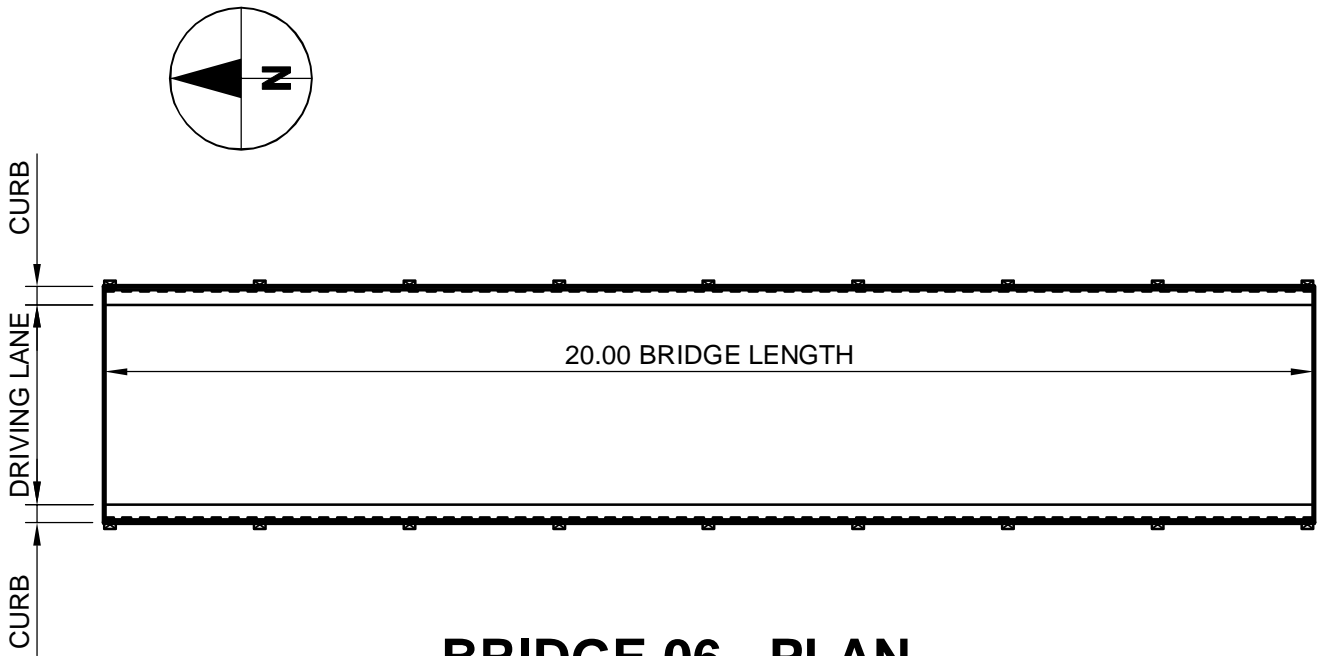

BRIDGE 06 - PLAN

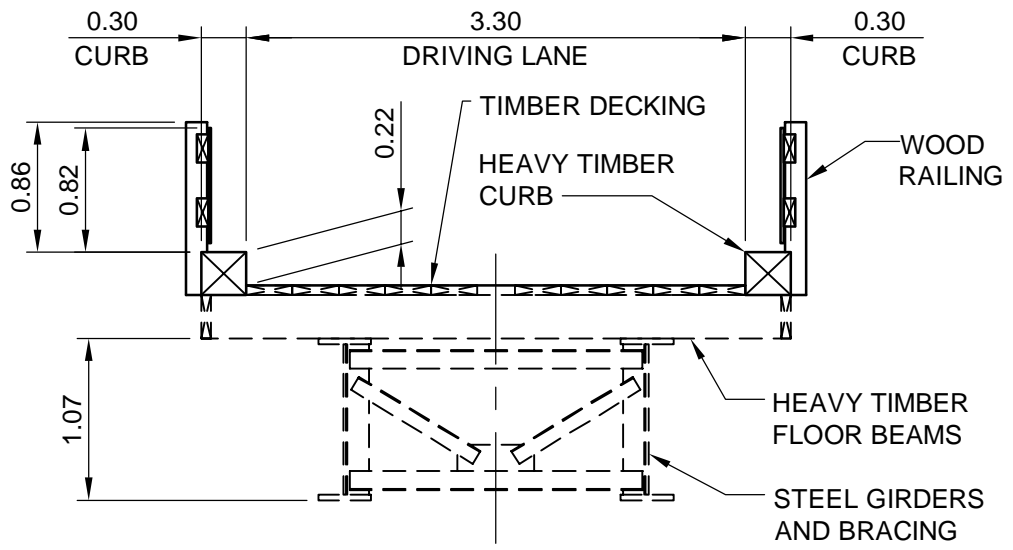

BRIDGE 06 - SECTION

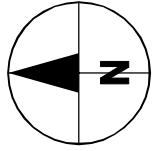

SIDEWALK

DRIVING LANE

CURB

18.05 BRIDGE LENGTH
(nts)

BRIDGE 07- PLAN

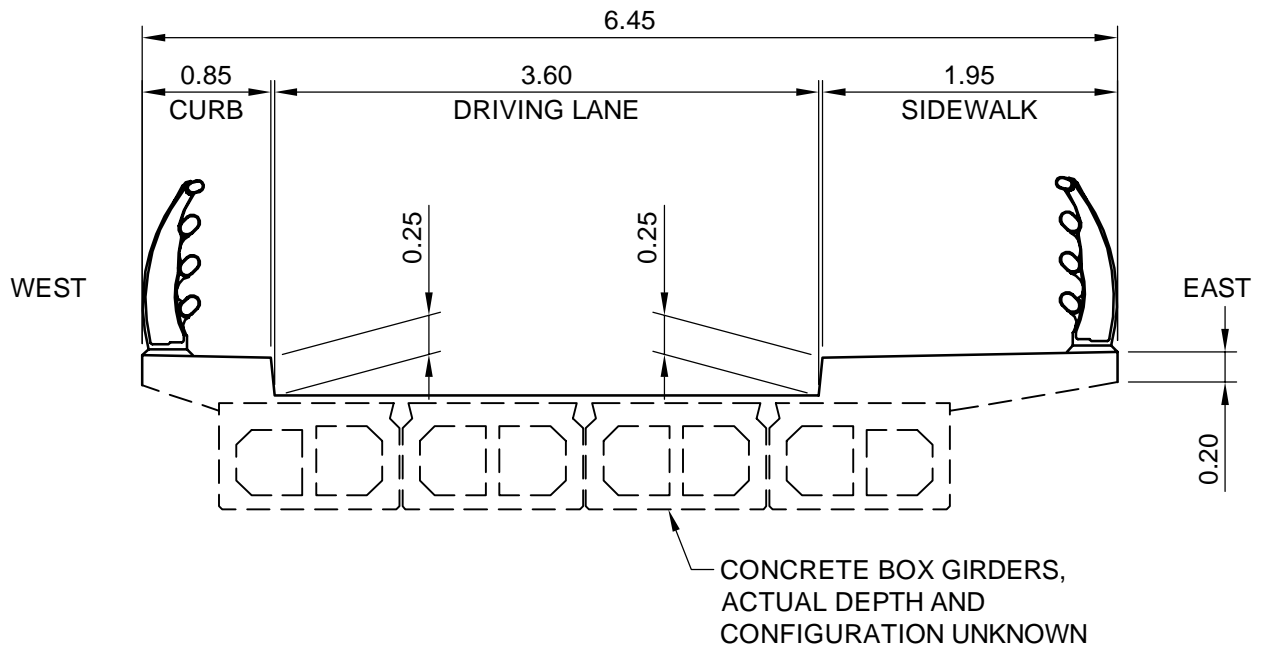

BRIDGE 07 - SECTION

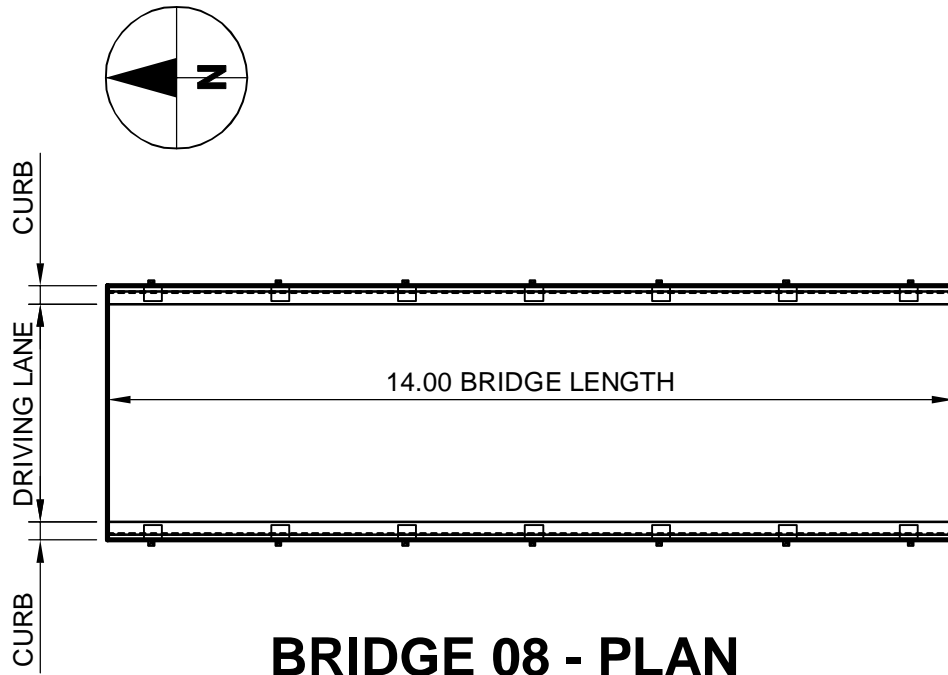

BRIDGE 08 - PLAN

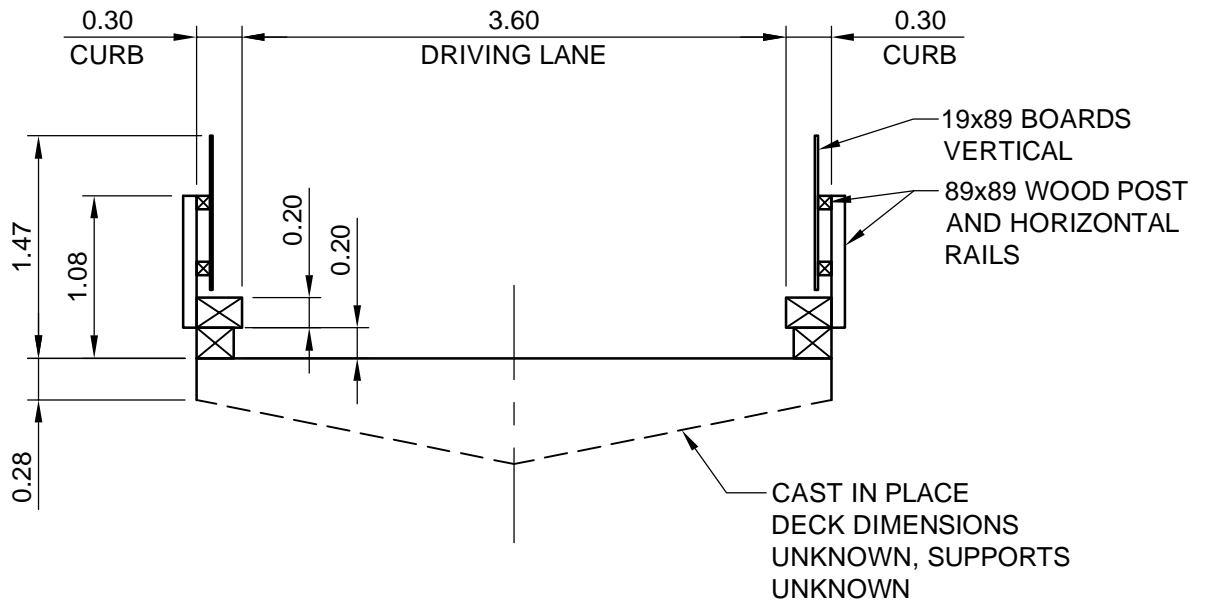

BRIDGE 08 - SECTION