



---

THE MUNICIPALITY OF THE VILLAGE OF LIONS BAY

---

**INFRASTRUCTURE COMMITTEE MEETING  
OF THE VILLAGE OF LIONS BAY  
HELD ON MONDAY, APRIL 24, 2017 at 7:00 PM  
COUNCIL CHAMBERS, 400 CENTRE ROAD, LIONS BAY**

---

**AGENDA**

- 1. Call to Order**
- 2. Appointment of Recorder**
- 3. Approval of the Agenda**
- 4. Public Questions & Comments**
- 5. Approval of Minutes**
  - A. Infrastructure Committee Meeting – March 27, 2017 (Page 3)
  - B. Action Items from the Minutes
- 6. Business Arising from the Minutes**
- 7. Unfinished Business**
  - A. UBC Water Hydrology Project Update
  - B. Metro Vancouver Water – Proposal Revisited
  - C. Howe Sound Water Source Matrix – Update and Information
  - D. Cell Towers Update
  - E. Bayview Road Work Update
  - F. Clean Water and Wastewater Fund (CWWF) Grant – Reporting Out
- 8. New Business**
  - A. Annual Drinking Water Quality Report (Page 7)
  - B. Harvey Weir Design (Page 87)
- 9. Public Questions & Comments**
- 10. Adjournment**

Intentionally Blank

LIONS BAY INFRASTRUCTURE COMMITTEE MEETING  
MONDAY 27 MARCH 2017 AT 7:00 PM  
UPPER ROOM, LIONS BAY COMMUNITY CENTER

MINUTES OF THE MEETING

In Attendance:

Fred Bain – Councilor and Committee Chair  
Naizam Jaffer – Public Works Manager  
Jim Mutrie – Resident  
Tony Greville – Resident  
Karl Buhr – Mayor  
Brian Ulrich – Resident

Regrets:

Jim Hughes – Councilor  
Peter Dejong - CAO

**1. Call to Order**

Meeting was called to order at 7:02 pm.

**2. Appointment of Recorder**

Regular recorder: Brian Ulrich

**3. Approval of the Agenda**

The Agenda was approved as tabled, with the following additions:

- 8. B. Leakdown Test
- 8. C. Community Safety Forum

**4. Public Participation**

No public questions or comments

**5. Approval of Minutes**

A. Corrections to 27 February 2017 IC meeting minutes:

The minutes indicated that Karl Buhr was not in attendance at the February meeting, which is incorrect. Minutes amended to show that Karl was present at the meeting.

B. Review of Action items from 27 February 2017 minutes.

From Section 5:

- Nai to see if we can obtain coverage from a cable cam system in action.

The cable cam quote is still in progress.

- Nai to do some research into who to talk with at Metro to resurrect the (water pipeline quote) initiative.

Done. Renewed talks with Metro are now well underway.

From Section 7:

- All to add more details to the water source matrix where data is missing. Ongoing. Anthony indicated that he is familiar with many of the water systems along Howe Sound and can fill in many of the missing data points.

## **6. Business Arising from the Minutes**

None.

## **7. Unfinished Business**

- A. UBC Water Hydrology Project. Update from Karl was that good progress has been made on the MOU. They (UBC) has made some good changes to it and has sent it to UILO (University-Industry Liaison Office) for processing. Steven has also procured 3 undergraduate students, 75% funded by NSERC and 25% from his grant funding. Their work, starting this summer, will include:
- Snow/topographic shadow observations and modelling,
  - Installation of streamflow gauging in the creeks to establish a rating curve
  - Search of new Internet of things platforms to develop a sensor network, develop hardware and test

With possible benefits to the UBC Study, Council has approved a \$20K communications study to determine the best way to establish effective data links between our SCADA system and our intakes, PRV's and other infrastructure items. Notwithstanding final study recommendations, cellular phone technology appears to be a leading candidate. A tower provider company will be meeting with Staff was to take place Thursday March 30<sup>th</sup>. Proposal is that they will build the tower at his cost on our (Village) land and he will rent it out with a percentage of the revenue going to the Village. Nai is working on the RFP for this. Update on this at next meeting.

Regarding continuity of the UBC Study, Anthony asked how we make sure the MOU stands alone so future council(s) will not cancel it and trash what we've started. The apparent answer is to get as many levels of government involved (Federal, Provincial, District etc.) so that the effort to get it cancelled is not worth the effort.

- B. Request to Metro Water District – Revisited. Covered by update on earlier action item; with staff now.
- C. Howe Sound Water Source Matrix - Update. In progress.

**ACTION:** Tony to fill in many of the blanks in the matrix with information for water systems along Howe Sound that he is familiar with.

In response to Karl's question from the previous meeting as to whether or not septic plumes influence well water, the answer is 'yes'. This means that any wells in the village would have to be located uphill from all private properties and septic fields so as not to be affected by them.

- D. Cell Towers Update. Status is as discussed above in relation to the UBC study.
- E. Bayview Road Work Update. The 50% design drawings are now being reviewed by Nai and Staff. The preliminary cost is approximately \$850K for everything. The stormwork portion of this is \$525K

## 8. New Business

- A. Clean Water and Wastewater Fund (CWWF) Grant – Report.  
The Village was granted one of two projects applied for; The \$2.1M Water Storage Facility RFP (tank replacement). The PRV upgrade grant was not awarded. The MP and MLA, Squamish/Whistler were to be on hand March 30<sup>th</sup> to award cheques and cut ribbons for the grants awarded to Lions Bay and other Howe Sound communities.

The engineering company retained for this study will review the models and determine the best location/elevation for the new tank(s). The current thinking is that fewer but bigger tanks is the preferred approach. Preliminary info indicates that the Highway tank is probably useless. We need 2 days worth of storage capacity if filling from the creek ever stops.

Next steps: Staff to issue the RFP.

Nai has been in contact with cell phone tower companies as part of the ongoing SCADA study. Since cell coverage in the village is less than satisfactory, particularly for the SCADA system, an additional tower(s) is an option for improving cellular signal here. Public works would want space on that tower for our SCADA connection needs and the residents would benefit from it overall.

- B. Leakdown Test.

We have done a leakdown test every March, and Karl was looking forward to this year's tests. Nai indicated that we are down staff and don't have bandwidth to do it at

this time so recommended that we will not do it. The test must be done overnight and invokes overtime costs. With our improved SCADA software, we can look at the consumption between 01:00 and 05:00 each day for 2 weeks to get the same data. It was agreed that this would satisfy the query.

Leak testing for leaks (on Village-side and private-side) has started again for this year in our ongoing effort to reduce consumption. provided an update on the Meeting with ISL on the progress. Preliminary drawings of the road cross section with subsurface drainage. The next set of drawings will include storm water and road profile with sidewalks.

**C. Community Safety Forum (18 May 2017)**

Ruth Simons has asked if the IC wants to talk again at this year's forum. The proposed topic would be water quality at the beach. We have lots of data on this since we check the beach water quality twice a week during the summer. Anthony agreed to speak on our behalf again this year on this topic. The presentation will include comparison with water quality at other local beaches like Eagle Harbor, West Vancouver, Wreck Beach etc.

**9. Public Questions and Comments**

There were no questions or comments from the gallery.

**10. Adjournment**

Meeting was adjourned at 8:23 pm.

**11. Next Meeting**

The next meeting will be Monday 24 April 2017 at 7:00 pm.



## THE MUNICIPALITY OF THE VILLAGE OF LIONS BAY

<b>Type</b>	<b>Information Report</b>		
<b>Title</b>	<b>2016 Annual Drinking Water Quality Report</b>		
<b>Author</b>	<b>Naizam Jaffer</b>	<b>Reviewed By:</b>	<b>Peter DeJong</b>
<b>Date</b>	<b>April 8, 2017</b>	<b>Version</b>	<b>1</b>
<b>Issued for</b>	<b>April 8, 2017 Regular Council Meeting</b>		

### **Recommendation:**

THAT the Information Report, "2016 Annual Drinking Water Quality Report" be received.

### **Attachments:**

(1) Village Of Lions Bay Drinking Water Quality Annual Report For 2016

### **Key Information:**

The *British Columbia Drinking Water Protection Act* and the *British Columbia Drinking Water Protection Regulation* (the "Act" and the "Regulation") mandate municipalities make public an annual report containing the results of their respective drinking water monitoring programs.

In 2016, staff conducted over 450 water sample tests from our drinking water distribution system, which were obtained from 6 sampling stations and from the two water treatment plants. Samples were tested on-site for turbidity and chlorine residual, while additional samples were sent to Vancouver Coastal Health's laboratories where it was tested for total coliform bacteria and E.coli. In addition, tests for metals and general chemistry biannually.

Key points in the report include:

- Total water consumption for the Village was 351,318 m<sup>3</sup>, an 86,115 m<sup>3</sup> decrease from the prior year
- The Village experienced 3 separate instances where the Magnesia Creek intake became blocked due to minor debris torrents resulting in a complete to partial loss of supply from this source for over 54 days
- The Village's Harvey Creek water treatment plant was disabled by a lightning strike resulting in a loss of water supply for 31 days

While the turbidity events and the lightning strike impacted our ability to provide water, it did not impact the quality of the Village's supply.

Based upon the testing results from this year's program, the Village's drinking water met the provincial requirements as outlined in the *Act* and *Regulation*.

**Follow Up Action:**

None required

**Communication Plan:**

Staff will post the Village Of Lions Bay Drinking Water Quality Annual Report For 2016 on the Village's website as required by the *Act* and the *Regulation*.



# VILLAGE OF LIONS BAY DRINKING WATER QUALITY ANNUAL REPORT

**FY 2016**

# TABLE OF CONTENTS

## Contents

INTRODUCTION _____	1
GENERAL DESCRIPTION _____	2
LICENSES _____	2
CONSUMPTION RATES _____	2
SOURCE WATER _____	4
ISSUES _____	4
CHALLENGES _____	4
TESTING & RESULTS _____	5
WATER TREATMENT _____	7
CHALLENGES & TURBIDITY EVENT RESPONSE _____	7
TESTING & RESULTS _____	8
DISTRIBUTION SYSTEM _____	9
TESTING & RESULTS _____	9
WORK PROGRAM - 2016 _____	11
WORK PROGRAM - 2017 _____	12
OPERATOR TRAINING _____	13

## Appendices

**APPENDIX A: WATER QUALITY SAMPLING SITE LOCATIONS AND TEST FREQUENCY**

**APPENDIX B: SOURCE & DISTRIBUTION WATER TESTING RESULTS**

**APPENDIX C: TURBIDITY V. CHLORINE RESIDUAL GRAPHS**

**APPENDIX D: METALS & WATER CHEMISTRY TEST RESULTS**

**APPENDIX E: BOIL WATER ADVISORIES ISSUED**

**APPENDIX F: EMERGENCY RESPONSE PLAN**

**APPENDIX G: VANCOUVER COASTAL HEALTH PERMIT TO OPERATE**

**APPENDIX H: EOCP FACILITY CLASSIFICATION**

**APPENDIX I: EOCP OPERATOR CERTIFICATES**

# INTRODUCTION

## INTRODUCTION

This report comprises the 2016 Drinking Water Quality Annual Report prepared by the Village of Lions Bay. It provides pertinent information about the Village's drinking water to support the Village's application for its annual Operating Permit, issued by the Medical Health Officer. The purpose of the report is to provide Village water consumers with drinking water sampling test results for 2016, as well as to present background information on Village-specific issues concerning water supply, treatment, and measures being taken to protect and enhance drinking water quality as per requirements under the *Drinking Water Protection Regulation* and the *Drinking Water Protection Act*.

Although the Village is a member of Metro Vancouver, its water supply is not sourced from the Greater Vancouver Water District (GVWD). The Village of Lions Bay owns and operates its own water supply, treatment, and distribution system, and has the water from its system analyzed for the presence of microbiological pathogens (and other indicator organisms), and metals by laboratories approved by the Medical Health Officer. Testing for chlorine residuals and turbidity levels are conducted by trained in-house staff.

# GENERAL DESCRIPTION

## GENERAL DESCRIPTION

The Village of Lions Bay supplies potable water to its customers via a waterworks system comprised of 2 intakes located on Harvey and Magnesia Creeks, 2 water treatment plants (which provide UV disinfection and chlorination) located downstream from the respective intakes, 5 storage tanks, 18 PRV stations, and 13 kilometers of water mains. A population of approximately 1,334 is served through 551 service connections.

## LICENSES

The Village of Lions Bay held 6 water licenses in 2016, issued by the Ministry of Environment. Of these licenses, 5 are currently being utilized. Table 1 lists the licenses and quantity of water associated with each.

Table 1. Village Water Licenses

License No	Imperial Quantity	Metric Quantity	Stream Name
C059405	10,000,000.00 gal/year	45,460.90000 m3/year	Magnesia Creek
C065267	4,380,000.00 gal/year	19,911.87420 m3/year	Magnesia Creek
C065316	7,300,000.00 gal/year	33,186.45700 m3/year	Magnesia Creek
C042330	18,250,000.00 gal/year	82,966.14250 m3/year	Alberta Creek *
C119916	9,125,000.00 gal/year	41,483.07125 m3/year	Harvey Creek
C119917	54,750,000.00 gal/year	248,898.42750 m3/year	Harvey Creek

\*Alberta Creek is not currently utilized by the Village

In 2016, a total volume of 351,317.76 m<sup>3</sup> of water was supplied to residents from the Magnesia and Harvey Creek surface water sources. This represents a year over year decrease of 19% when compared to 2015 and a 54.5% decrease from 2017.

Table 2. Total Treated Water Production from Magnesia and Harvey Creek

Year	2016	2015	2014
m3	351,318	437,433	772,301

## CONSUMPTION RATES

Summer 2016 on the south coast saw a return to average temperatures and slightly higher-than-average rainfall. As a result, the Village's Outdoor Water Use Bylaw conservation levels did not drop below the level one stage.

The Public Works Department's leak detection program identified a total of 12 private side leaks and one municipal side leak.

Table 3 provides a month by month comparison with average Village daily consumption rates (USG) and the percentage change year over year.

## GENERAL DESCRIPTION

Table 3. Average Daily Consumption Rates 2015 vs. 2016

Month	2015 (USG)	2016 (USG)	Percentage change
January	381,273	200,312	47% ↓
February	382,268	198,256	48% ↓
March	391,763	196,146	50% ↓
April	390,755	235,808	40% ↓
May	357,663	295,110	17% ↓
June	401,600	155,573	61% ↓
July	349,890	353,757	1% ↑
August	292,394	326,024	12% ↑
September	254,540	269,984	6% ↑
October	273,092	203,117	26% ↓
November	197,812	174,518	12% ↓
December	175,062	229,071	31% ↑

# SOURCE WATER

## SOURCE WATER

The Village of Lions Bay's watershed areas include Magnesia Creek drainage (421 hectares), Harvey Creek drainage (635 hectares), Alberta Creek drainage (51 hectares), and Rundle Creek drainage (20 hectares). The Village's total water supply is drawn from the Magnesia Creek and Harvey Creek watersheds. The Public Works Department is responsible for water acquisition, supply, treatment, and distribution to the Village's residents.

The Village is systematically working toward a "4-barrier" approach to mitigate source water quality issues that include the potential for waterborne disease, seasonal raw water turbidity fluctuations, and bacterial regrowth in its distribution system. The barriers are as follows: primary (UV) and secondary (chlorine) treatment, water quality monitoring (daily, weekly, and biannually), water main cleaning/flushing (biannually), and watershed protection (in progress).

## ISSUES

Adequate supply for both residential consumption and fire protection is the primary issue for the Village, as both creek flow levels vary throughout the year. Harvey Creek flow levels are the more volatile of the two, ranging from 1,279.2 gallons per minute (May 2) to 268.9 gallons per minute (October 14) entering the treatment plant in 2016. Conversely, Magnesia Creek flows appear more stable year round; however, Village crews manually limit the amount of water taken from Magnesia due to operational considerations downstream.

Between July 25 and September 02 of 2016, Public Works were able to measure the full flow of Magnesia Creek thanks to the installation of a new pressure reducing valve just upstream of the treatment plant. Over this period, high flows peaked at 998.1 gallons per minute (August 10) while low flows dropped to 211.9 gallons per minute (August 4).

## CHALLENGES

The Village draws all of its water from surface sources that are subject to fluctuating turbidity levels, and are designated as unstable terrain upslope. This fluctuation in raw water turbidity presents many challenges for the treatment of the water to ensure that turbidity and chlorine residuals throughout the entire supply system are not adversely affected. The water treatment plants are monitored remotely via a SCADA system, and are checked daily (Monday through Friday) by crews; each intake is checked at least weekly, unless safe work procedures prohibit entry to the intake road.

The watershed areas for the intakes are contained by steep, rocky, unstable terrain upslope on one side, and steep flowing creeks subject to debris torrents on the other. Access to the intakes is via narrow gravel roads which are subject to rock fall and tree throw hazards from above. Strict safe working guidelines for unstable terrain upslope prohibit crews from entering the watershed areas and water intakes if rainfall parameters are exceeded. This prevents crews from being able to investigate

## SOURCE WATER

decreased water flow or increased raw water turbidity levels during periods of heavy rain – the exact times most likely to cause either event.

In 2016 the Village of Lions Bay experienced four separate water outages, three caused by minor debris torrents which blocked the raw water intakes and one caused by a lightning strike to our Water Treatment Plant which resulted in a meltdown of some treatment plant controls. For the duration of these outages residents were put on water restrictions and kept up to date via alerts posted on the Village’s website and through an email notification system for those residents who elect to be notified in this manner.

**Table 4. 2016 Water Outages**

Start Date	Duration of outage (days)	Surface Water Supply System	Cause
<i>January 12, 2016</i>	28	Magnesia Creek	Minor debris torrent resulting in blocked intake.
<i>May 27, 2016</i>	31	Harvey Creek	Lightning strike disabled treatment plant controls.
<i>October 15, 2016</i>	11	Magnesia Creek	Minor debris torrent resulting in blocked intake.
<i>November 3, 2016</i>	15	Magnesia Creek	Minor debris torrent resulting in blocked intake.

### TESTING & RESULTS

The Village tests raw source water for turbidity from both creeks daily (work days). More extensive testing is undertaken biannually for general water chemistry, hardness, metals, and other contaminants including organic compounds. Table 5 presents the Village’s raw water turbidity test results for 2016.

**Table 5. 2016 Raw Water Turbidity Results**

	Harvey Creek	Magnesia Creek
Count	251	237
Maximum result (NTU)	3.42	8.69
Minimum result (NTU)	0.11	0.15
Average (NTU)	0.60	0.51
Number >5 NTU	0	2
Percentage > 5 NTU	0.40%	0.85%

Section 3.3 of the 2003 Guidelines for Canadian Drinking Water Quality Supporting Documentation titled “Turbidity, Criteria for Exclusion of Filtration in Waterworks Systems” contains a provision for exemption from its recommendation of filtration for all surface water supplies if the system’s average daily source water turbidity levels measured immediately prior to where disinfection is applied are around 1.0 NTU but do not exceed 5.0 NTU for more than 2 days in a 12-month period. As indicated in Table 4, raw water turbidity did not exceeded 5 NTUs from Harvey Creek, and exceeded 5 NTUs twice from Magnesia Creek.

## SOURCE WATER

Elevated turbidity levels caused by debris slides and stream scouring upslope of the Village's intakes have resulted in boil water advisories issued by Vancouver Coastal Health in previous years. No boil water advisories were issued for 2016.

Appendix B contains all source raw water test results for 2016 while Appendix E contains copies of all boil water advisories issued for 2016 (none).

The Village further tests twice a year for metals and general chemistry of its treated and raw water, including hardness, pH, total suspended solids, turbidity, alkalinity, organic carbon, biochemical oxygen demand (BOD), and trihalomethanes. Appendix D contains the 2016 raw water metals and general chemistry test results.

# WATER TREATMENT

## WATER TREATMENT

The Village of Lions Bay does not have a filtration system. Raw water from Harvey and Magnesia Creek intakes is treated via a 2-stage process within their respective treatment plants – the primary stage is disinfection utilizing ultraviolet radiation (UV), and the secondary stage is chlorine injection. This 2-stage process is required because although UV is very effective at inactivating Giardia and Cryptosporidium, it does not introduce any disinfectant residual to the water, rendering it incapable of protecting the distribution system against contamination. Therefore, chlorination is used as the secondary stage of disinfection in order to establish a residual throughout the system.

The Village tests samples which are taken daily (Monday to Friday) for turbidity and chlorine residuals from 6 sampling stations located in the middle and ends of the distribution system, in addition to those taken from the 2 tanks located at the treatment plants. Once a week, further samples are taken from each of the aforementioned sites and sent to a Vancouver Coastal Health approved testing laboratory and tested for E. coli and total coliforms along with raw water samples before and after the UV reactors.

The Drinking Water Protection Regulation's water quality standards for potable water indicate that there can be no detectable E. coli per 100ml; and that total coliform bacteria samples (for more than 1 sample taken per month) must have at least 90% of samples with no detectable total coliform bacteria per 100ml and no 1 sample can have more than 10 total coliform bacteria per 100ml. No test samples taken weekly from the Village's 2 tanks or the 6 sampling stations exceeded these parameters in 2016.

## CHALLENGES & TURBIDITY EVENT RESPONSE

The challenges outlined in the Source Water Section of this report also impact the Village's water treatment plants. The performance of the primary UV treatment is affected by increased turbidity because water that has higher turbidity absorbs a significant amount of UV light, and will therefore have a correspondingly low UV transmittance (UVT) rate. The UV system automatically increases lamp intensity to counter the lower UVT. If turbidity exceeds 5 NTUs entering the plants, the UV system will send an alarm through SCADA to notify the Water Operator, and the UV reactor shuts down. During turbidity events in excess of 5 NTU, microbiological sampling and testing is increased at all sampling locations; chlorine residual sampling and testing is likewise increased; and the Village will contact Vancouver Coastal Health, who may issue a Boil Water Advisory. Appendix F contains the Village's Emergency Response Plan.

In times of severe weather, the Water Operator increases the frequency of testing and adjusts chlorine injection rates to compensate for any fluctuating chlorine demand caused by varying turbidity levels. The generally agreed minimum acceptable residual chlorine level for treated drinking water at all points in the distribution system is 0.2ppm; and the maximum is 4ppm.

# WATER TREATMENT

## TESTING & RESULTS

Table 6 presents an overview of the Village's treated water turbidity results at Harvey and Magnesia storage tanks located directly downstream of their respective treatment plants. Table 7 presents an overview of the chlorine residuals at the same storage tanks. Appendix C contains graphs of turbidity and chlorine residual test results.

**Table 6. 2016 Village Treated Water Turbidity at Tanks**

	<b>Harvey tank</b>	<b>Magnesia tank</b>
Count	251	236
Maximum NTU	4.06	2.97
Minimum NTU	0.11	0.14
Average NTU	0.67	0.47
Number >5 NTU	0	0
Percentage >5 NTU	0%	0%

**Table 7. 2016 Village Chlorine Residuals at Tanks**

	<b>Harvey tank</b>	<b>Magnesia tank</b>
Count	251	251
Maximum ppm	1.13	2.41
Minimum ppm	0.49	0.11
Average ppm	0.89	0.50
Number <0.2 ppm	0	0
Percentage <0.2 ppm	0%	0%

# DISTRIBUTION SYSTEM

## DISTRIBUTION SYSTEM

The Village of Lions Bay's distribution system serves a population of approximately 1,348 residents accounting for essentially 100% of the Village's annual water consumption. As the Village is located on a mountainside, water pressure within the Village's 13km of water mains is controlled by 18 PRV stations; 10 of which are located on the Harvey Creek supplied system, and 8 on the Magnesia Creek supplied system. These mains are constructed primarily of ductile iron (DI), however a variety of materials, including asbestos cement (AC), cast iron (CI), and PVC also exist within the Village. The oldest pipes in the Village's distribution system were installed between 1970 and 1971. Village Public Works crews are able to seamlessly switch the supply source of the water in the distribution system in the event that one source is compromised or offline, although water pressure is significantly reduced for residents of upper Sunset Drive if the Village is being supplied solely by Harvey Creek.

There are 8 storage tanks located on the system, 5 of which were in use in the potable water system in 2016. These 5 were Harvey tank (480,380 USG), Magnesia tank (120,095 USG), Phase 4 tank (24,019 USG), Phase 5 tank (30,024 USG), and the Highway tank (25,220 USG). In 2015, both Brunswick tank (42,000 USG) and Oceanview tank (100,000 USG) were filled with water to act as emergency fire reserves. These tanks do not contain potable water, and are isolated from the Village's potable water system.

In 2016, 351,318 m<sup>3</sup> or 92,808,397 US gallons of water was supplied to the Village from Magnesia and Harvey creeks through 591 service connections. This equates to a rough average of 959.8 m<sup>3</sup> or 253,575 US gallons consumed by the Village per day.

## TESTING & RESULTS

The Village tests samples which are taken daily (workdays) for turbidity and chlorine residuals from 6 sampling stations located in the middle and ends of the distribution system, in addition to those taken from the 2 tanks located at the treatment plants, to ensure all meet the generally accepted minimum residual of 0.2ppm for chlorine residual and are less than 5 NTU for turbidity. Once a week, further samples from each of the 6 sampling stations are sent to a Vancouver Coastal Health approved testing laboratory and tested for E. coli and total coliforms.

The Drinking Water Protection Regulation's water quality standards for potable water indicate that there can be no detectable E. coli per 100ml; and that total coliform bacteria samples (for more than 1 sample taken per month) must have at least 90% of samples with no detectable total coliform bacteria per 100ml and no 1 sample can have more than 10 total coliform bacteria per 100ml. No test sample results taken weekly from the Village's distribution and storage system exceeded these parameters in 2016.

## DISTRIBUTION SYSTEM

Tables 8 and 9 presents an overview of the Village's treated water turbidity results on each of the two water systems: Harvey and Magnesia. Tables 10 and 11 present an overview of the Village's chlorine residual results on the Harvey and Magnesia distribution systems respectively. Appendix A lists all sample site locations, the tests performed, and the frequency of testing at each. Appendix B contains all Village treated water test results for 2016.

**Table 8. 2016 Turbidity Results in Harvey Distribution System**

	<b>PRV-3</b>	<b>CAFÉ</b>	<b>LIONS BAY AVE</b>	<b>KELVIN GROVE</b>
Count	251	251	251	251
Maximum NTU	2.41	2.55	2.84	3.88
Minimum NTU	0.11	0.13	0.11	0.13
Average NTU	0.50	0.37	0.32	0.31
Number >5 NTU	0	0	0	0
Percentage >5 NTU	0%	0%	0%	0%

**Table 9. 2016 Turbidity Results in Magnesia Distribution System**

	<b>PRV-5</b>	<b>BRUNSWICK BEACH</b>
Count	251	251
Maximum NTU	1.79	1.44
Minimum NTU	0.12	0.14
Average NTU	0.34	0.34
Number >5 NTU	0	0
Percentage >5 NTU	0%	0%

As indicated in Tables 8 and 9 above, the Village's treated water turbidity on both distribution systems was on average less than  $\frac{1}{2}$  of 1 NTU and was not in excess of 5 NTU in any samples taken in 2016.

**Table 10. 2016 Chlorine Residual Results in Harvey Distribution System**

	<b>PRV-3</b>	<b>CAFÉ</b>	<b>LIONS BAY AVE</b>	<b>KELVIN GROVE</b>
Count	251	251	251	251
Maximum ppm	1.10	1.05	0.94	1.08
Minimum ppm	0.43	0.20	0.20	0.20
Average ppm	0.85	0.65	0.63	0.52
Number <0.2 ppm	0	0	0	0
Percentage <0.2 ppm	0%	0%	0%	0%

## DISTRIBUTION SYSTEM

**Table 11. 2016 Chlorine Residual Results in Magnesia Distribution System**

	PRV-5	BRUNSWICK BEACH
Count	251	251
Maximum ppm	1.21	1.12
Minimum ppm	0.28	0.20
Average ppm	0.83	0.62
Number <0.2 ppm	0	0
Percentage <0.2 ppm	0%	0%

As indicated in Tables 10 and 11 above, the Village's treated water chlorine residuals on both distribution systems was on average less than 1ppm; and was not below 0.2ppm in any samples taken in 2016. As indicated in the Water Treatment Section of this report, the Water Operator adjusts chlorine injection rates to compensate for any fluctuating chlorine demand caused by varying turbidity levels, and must ensure that all points in the system show minimum residuals. The generally agreed minimum acceptable residual chlorine level for treated drinking water at all points in the distribution system is 0.2ppm; the maximum is 4ppm.

Appendix C contains comparison graphs of turbidity and chlorine residual test results.

The Village further tests 10 locations twice a year for metals and general chemistry of its treated and raw water, including hardness, pH, total suspended solids, turbidity, alkalinity, organic carbon, biochemical oxygen demand (BOD), and trihalomethanes. First draw test results from samples taken in April for lead exceeded the limits set in the Guidelines for Canadian Drinking Water Quality of a maximum acceptable concentration of 0.010 mg/L measured at the tap in 1 location – at the Public Work Yard in Kelvin Grove. Given that lead test results have been consistently low in the distribution system, the most likely sources of lead found in these locations would be from lead in the private-side service lines, lead solder in plumbing, or brass fittings such as faucets. Both locations tested below the acceptable limit after flushing. In April and September, the Public Works Yard's first draw tests were above the acceptable limit but tested below the acceptable limit after flushing. Appendix D contains metals and general chemistry test results for 2016.

### WORK PROGRAM - 2016

In addition to the standard work program which includes system-wide flushing and leak detection, the Village's Public Works Department performed minor upgrades to 12 of the Village's pressure reducing valve (PRV) stations.

Capital upgrades funded by the New Building Canada Fund (NBCF) program included the installation of a PRV upstream of the Magnesia water treatment plant to mitigate infrastructure and safety concerns for staff working on or near this main and in the treatment plant; and the installation of a bypass at the Magnesia water treatment plant to ensure that regular maintenance or emergency work to the water

## DISTRIBUTION SYSTEM

plant can be undertaken without shutting down the entire supply system. Additional components of the NBCF grant program included road safety improvements to both access roads.

### **WORK PROGRAM - 2017**

The Village's Public Works Department will perform Village-wide hard water main flushing in April and October of 2017. This will augment the biennial leak detection program for all residences and commercial facilities throughout the Village.

Part of the NBCF grant is to install a new infiltration intake design to be retrofitted to the existing Magnesia intake to mitigate the impact of sediment debris that enters the system and reduces the amount of time staff must spend at the intake itself to manually clean out debris. The infiltration gallery could not be installed in 2016 due to above average streamflow and so will be attempted this summer during the low flow window in late August.

Further to this, the balance of the NBCF intended for the installation of an infiltration gallery at the Harvey Creek intake will be repurposed to address deficiencies discovered in the main structure of the intake weir. Approvals have been granted for this repurposing as well as an extension to the construction timelines.

Finally, the Village's application to the federal and provincial Clean Water and Wastewater program for the replacement of the Village's water storage facilities was successful. As a result, the Village has initiated preparatory research in the form of water modeling in order to determine the most suitable arrangement, location, and sizing of new potable water storage facilities in the community. It is anticipated that redundant storage facilities will be eliminated and that larger, more efficient storage facilities will be constructed in 2017.

# OPERATOR TRAINING

## OPERATOR TRAINING

The BC Drinking Water Protection Regulation outlines water system operator qualification standards. Water systems are classified by the Environmental Operators Certification Program (EOCP), based on the population served and the complexity of the system. The chief “operator(s)” of the system must, in turn, be certified by the EOCP at the matching classification level of the system. The Village’s water treatment and distribution system has been evaluated as a “Level 2” classification. The Village currently has one water distribution system operator (Alberto Urrutia) with Level 2 certification from the EOCP.

The Village recognizes the inherent value that operator education training and education provides and ensures that its operator participates annually in a variety of product orientation, workshops, and technical courses that become available annually. In 2016, the course undertaken to maintain the year’s mandatory Continuing Education Units (CEUs) was Confined Space Entry and Water Distribution II. In addition to this, two more Village Public Works employees were certified as Water Distribution 1 Operators through the EOCP.

The Village’s two water treatment facilities were assessed and classified as Class 1 water treatment plants. The Village’s lead operator, Alberto Urrutia, will begin coursework and write the certification exam in 2017 to match the treatment plants Class 1 designation.

Appendices H and I, respectively, contain the Village’s EOCP water system facility classifications and operator certifications.

## APPENDIX A: WATER QUALITY SAMPLING SITE LOCATIONS AND TEST FREQUENCY

# SAMPLE STATIONS AND TESTS

## SAMPLE STATIONS AND TESTS

Tests	Location	Source	Frequency
Chlorine Residual & Turbidity (Treated Water)	PRV-3	Harvey Creek	Daily (workdays)
	Harvey Tank	Harvey Creek	Daily (workdays)
	Lions Bay Café	Harvey Creek	Daily (workdays)
	Lions Bay Avenue	Harvey Creek	Daily (workdays)
	Kelvin Grove	Harvey Creek	Daily (workdays)
	PRV-5	Magnesia Creek	Daily (workdays)
	Magnesia Tank	Magnesia Creek	Daily (workdays)
	Brunswick Beach	Magnesia Creek	Daily (workdays)

Test	Location	Source	Frequency
Raw Water Turbidity	Harvey Intake	Harvey Creek	Daily (workdays)
	Magnesia Intake	Magnesia Creek	Daily (workdays)

Tests	Location	Source	Frequency
Treated Water Bacteriological (E. coli & total coliforms)	PRV-3	Harvey Creek	weekly
	Harvey Tank	Harvey Creek	weekly
	Lions Bay Café	Harvey Creek	weekly
	Lions Bay Avenue	Harvey Creek	weekly
	Kelvin Grove	Harvey Creek	weekly
	Harvey Raw Water	Harvey Creek	monthly
	Harvey UV Reactor	Harvey Creek	monthly
	PRV-5	Magnesia Creek	weekly
	Magnesia Tank	Magnesia Creek	weekly
	Brunswick Beach	Magnesia Creek	weekly
	Magnesia Raw Water	Magnesia Creek	monthly
	Magnesia UV Reactor	Magnesia Creek	monthly

Test	Location	Source	Frequency
Raw Water Turbidity	Harvey Intake	Harvey Creek	Daily (workdays)
	Magnesia Intake	Magnesia Creek	Daily (workdays)

## SAMPLE STATIONS AND TESTS

<b>Tests</b>	<b>Location</b>	<b>Source</b>	<b>Frequency</b>
Treated Water Metals & Chemical	Harvey Tank	Harvey Creek	2x annually
Composition	Lions Bay Café	Harvey Creek	2x annually
	Lions Bay Avenue	Harvey Creek	2x annually
	Kelvin Grove	Harvey Creek	2x annually
	Community Centre	Harvey Creek	2x annually
	Magnesia Tank	Magnesia Creek	2x annually
	Brunswick Beach	Magnesia Creek	2x annually

<b>Test</b>	<b>Location</b>	<b>Source</b>	<b>Frequency</b>
Raw Water Metals & Chemical	Harvey Intake	Harvey Creek	2x annually
Composition	Magnesia Intake	Magnesia Creek	2x annually

## APPENDIX B: SOURCE & DISTRIBUTION WATER TESTING RESULTS

### Village of Lions Bay - Source Water NTU Results

	January		February		March	
	Harvey	Magnesia	Harvey	Magnesia	Harvey	Magnesia
1			0.46	0.44	0.88	0.29
2			0.29	0.46	1.23	0.75
3			0.25	0.50	0.51	0.77
4	0.11	0.23	0.37	0.60	0.4	0.39
5	0.15	0.23	0.45	0.74		
6	1.45	0.49				
7	0.64	0.30			0.39	0.34
8	0.68	0.58			1.04	0.21
9			0.95	0.64	0.48	1.73
10			0.44	0.55	1.14	4.39
11	0.46	0.30	0.62	0.30	0.59	2.00
12	0.37	N/A	0.66	0.75		
13	2.13	N/A				
14	0.38	N/A			0.65	0.76
15	0.41	N/A	0.67	0.39	0.5	0.4
16			0.66	0.53	1.04	0.54
17			0.34	0.46	0.34	0.28
18	0.58	N/A	0.88	0.45	0.55	0.24
19	0.47	N/A	0.37	0.52		
20	0.48	N/A				
21	0.97	N/A			0.77	0.37
22	3.42	N/A	0.51	0.23	0.61	1.01
23			0.31	0.28	0.61	1.14
24			0.33	0.36	0.61	0.27
25	0.94	N/A	0.73	0.32		
26	0.63	N/A	0.28	0.37		
27	0.84	N/A			0.14	0.35
28	2.59	N/A				
29	0.68	N/A	0.71	0.23	0.48	1.1
30					0.74	0.27
31					0.35	0.38

## APPENDIX B: SOURCE & DISTRIBUTION WATER TESTING RESULTS

### Village of Lions Bay - Source Water NTU Results

	April		May		June	
	Harvey	Magnesia	Harvey	Magnesia	Harvey	Magnesia
1	0.41	0.52			0.19	0.44
2			0.34	0.52	0.41	0.43
3			0.67	0.33	0.30	0.48
4	0.30	0.43	0.64	0.3		
5	0.21	0.24	0.35	0.25		
6	0.62	0.47	0.34	0.22	0.82	0.91
7	1.20	0.35			0.30	0.55
8	0.63	0.31			0.34	0.54
9			0.54	0.25	0.48	0.24
10			0.37	0.19	0.41	0.28
11	0.20	0.28	0.15	0.21		
12	0.27	0.28	0.31	0.24		
13	0.17	0.20	0.36	0.35	0.33	0.16
14	0.22	0.29			0.31	0.24
15	0.21	0.25			0.18	0.32
16			0.2	0.2	0.22	0.16
17			0.32	0.48	0.32	0.46
18	0.26	0.26	0.3	0.25		
19	0.46	0.31	0.29	0.41		
20	0.28	0.45	0.26	0.25	0.55	0.36
21	0.43	0.77			0.30	0.24
22	0.70	0.37			0.46	0.20
23					0.72	0.86
24			0.88	0.24	0.37	0.43
25	0.70	0.28	0.42	0.24		
26	0.31	0.24	0.56	0.26		
27	0.33	0.26	0.32	0.5	0.27	0.19
28	0.33	0.22			0.24	0.23
29	0.43	0.27			0.20	0.24
30			0.35	0.41	0.18	0.25
31			0.35	1.55		

## APPENDIX B: SOURCE & DISTRIBUTION WATER TESTING RESULTS

### Village of Lions Bay - Source Water NTU Results

	July		August		September	
	Harvey	Magnesia	Harvey	Magnesia	Harvey	Magnesia
1					0.78	0.19
2			0.40	0.21	0.64	0.31
3			0.45	0.32		
4	0.24	0.2	0.52	0.29		
5	0.36	0.16	0.53	0.29		
6	0.39	0.46			0.69	0.17
7	0.38	0.48			0.52	0.34
8	1.45	0.82	1.44	0.30	0.76	0.19
9			0.70	0.36	0.48	0.16
10			1.41	0.23		
11	0.63	0.25	0.35	0.25		
12	0.84	0.23	0.82	0.37	1.15	0.17
13	0.4	0.67			0.61	0.21
14	0.59	0.31			0.56	0.2
15	0.65	0.29	1.38	0.22	0.22	0.24
16			0.52	0.20	0.56	0.33
17			0.76	0.21		
18	0.86	1	0.25	0.19		
19	1.02	0.3	0.58	0.16	1.55	0.35
20	0.76	0.22			0.42	0.17
21	0.43	0.37			0.33	0.24
22	0.48	0.25	1.32	0.28	0.42	0.19
23			0.56	0.15	1.18	0.23
24			0.61	0.15		
25	1.26	0.23	0.47	0.18		
26	0.41	0.94	0.53	0.31	1.21	0.31
27	0.53	1.23			0.27	0.15
28	0.76	0.44			0.5	0.49
29	0.65	0.3	1.12	0.18	0.83	0.22
30			0.66	0.27	0.5	0.19
31			0.72	0.28		

## APPENDIX B: SOURCE & DISTRIBUTION WATER TESTING RESULTS

### Village of Lions Bay - Source Water NTU Results

	October		November		December	
	Harvey	Magnesia	Harvey	Magnesia	Harvey	Magnesia
1			0.39	0.33	0.30	0.28
2			1.65	0.35	0.49	0.51
3	0.31	0.18	0.62	0.53		
4	1.07	0.18	2.03	0.44		
5	0.58	0.7			0.32	0.41
6	0.74	0.35			0.48	0.52
7	3.23	8.68	0.6	1.86	0.35	0.23
8			0.47	0.63	0.26	0.26
9			0.87	1.22	0.33	0.23
10			0.35	0.42		
11	1.17	0.37				
12	0.54	0.27			0.27	0.47
13	0.63	0.69			0.33	0.34
14	0.66	1.31	0.94	1.76	0.24	0.32
15			0.37	0.49	0.23	0.28
16			0.29	0.58	0.30	0.21
17	1.22	8.69	0.35	0.52		
18	0.65	1.3	0.36	0.59		
19	0.56	0.77			0.32	0.22
20	0.99	0.76			0.50	0.39
21	0.34	0.47	0.68	0.73	0.51	0.44
22			0.71	0.38	0.27	0.22
23			0.79	1.03	0.29	0.31
24	0.77	0.69	0.53	1.47		
25	0.80	0.4	0.66	0.79		
26	0.65	0.85			0.33	0.22
27	0.76	0.54				
28	1.19	0.67	0.76	0.35	0.57	0.19
29			0.65	0.28	0.49	0.55
30			0.93	0.81	0.30	0.47
31	0.4	0.61				

# APPENDIX B: SOURCE & DISTRIBUTION WATER TESTING RESULTS

## Village of Lions Bay Distribution System NTU and CL<sup>2</sup> Results

Date	TREATED WATER JANUARY 2016															
	HARVEY							MAGNESIA								
	400 HAR. TANK		PRV-3		STORE/CAFÉ		LIONS BAY AVE.		KELVIN GROVE		100 MAG. TANK		PRV-5		BRUNSWICK B.	
	Turbidity (NTU)	CL2 Res. (ppm)	Turbidity (NTU)	CL2 Res. (ppm)	Turbidity (NTU)	CL2 Res. (ppm)	Turbidity (NTU)	CL2 Res. (ppm)	Turbidity (NTU)	CL2 Res. (ppm)	Turbidity (NTU)	CL2 Res. (ppm)	Turbidity (NTU)	CL2 Res. (ppm)	Turbidity (NTU)	CL2 Res. (ppm)
1																
2																
3																
4	0.18	0.94	0.18	0.78	0.20	0.72	0.20	0.79	0.27	0.65	0.24	1.06	0.20	1.04	0.21	1.12
5	0.11	0.92	0.18	0.93	0.23	0.72	0.29	0.79	0.25	0.74	0.23	1.07	0.17	1.02	0.32	0.82
6	1.11	0.82	0.72	0.79	0.62	0.72	0.57	0.74	0.15	0.90	0.51	0.91	0.28	0.92	0.51	0.91
7	2.14	0.94	0.41	0.93	0.34	0.66	0.45	0.81	0.22	0.68	0.35	0.91	0.31	0.84	0.37	0.86
8	3.33	0.81	1.90	0.77	0.52	0.55	0.63	0.71	1.38	0.64	0.26	0.88	0.30	0.85	0.53	0.80
9																
10																
11	0.51	0.92	0.57	0.89	0.25	0.77	0.19	0.63	0.20	0.42	0.34	0.88	0.21	0.82	0.22	0.65
12	1.02	0.93	1.47	0.90	0.78	0.74	1.02	0.72	0.34	0.72	N/A	N/A	1.79	0.84	0.72	0.56
13	2.92	0.75	0.67	0.72	1.73	0.60	0.63	0.71	0.14	0.56	N/A	N/A	0.76	0.80	0.29	0.63
14	0.65	0.95	0.74	0.93	0.60	0.63	0.40	0.69	0.77	0.57	N/A	N/A	0.43	0.78	0.41	0.57
15	0.48	0.95	0.57	0.92	0.38	0.71	0.28	0.57	0.75	0.41	N/A	N/A	0.63	0.93	0.24	0.56
16																
17																
18	0.35	1.06	0.59	1.03	0.36	0.79	0.25	0.84	0.42	0.69	N/A	N/A	0.35	0.98	0.25	0.55
19	2.23	1.10	1.42	1.07	0.55	0.78	0.86	0.79	0.25	0.65	N/A	N/A	0.33	1.00	0.30	0.70
20	1.23	1.06	1.88	1.03	1.05	0.77	0.99	0.77	0.24	0.74	N/A	N/A	0.79	0.94	0.43	0.62
21	0.92	1.08	0.31	1.05	0.92	0.75	0.61	0.76	0.46	0.64	N/A	N/A	0.21	0.95	0.32	0.63
22	0.93	0.93	0.90	0.90	0.72	0.72	0.74	0.74	0.66	0.66	N/A	N/A	0.80	0.91	0.25	0.64
23																
24																
25	0.53	0.95	1.15	0.91	0.41	0.72	0.40	0.56	0.58	0.35	N/A	N/A	0.49	0.80	0.29	0.41
26	0.62	0.98	0.56	0.95	0.38	0.77	0.73	0.86	0.52	0.55	N/A	N/A	0.92	0.88	0.83	0.35
27	3.40	0.94	1.79	0.90	1.23	0.69	1.48	0.71	0.42	0.63	N/A	N/A	0.92	0.81	0.54	0.38
28	1.74	0.83	2.18	0.80	1.47	0.63	1.17	0.83	0.35	0.61	N/A	N/A	1.72	0.78	0.49	0.41
29	1.46	0.85	1.28	0.82	0.74	0.56	0.50	0.66	0.70	0.53	N/A	N/A	0.81	0.70	0.46	0.43
30																
31																

# APPENDIX B: SOURCE & DISTRIBUTION WATER TESTING RESULTS

## Village of Lions Bay Distribution System NTU and CL<sup>2</sup> Results

		TREATED WATER FEBRUARY 2016														
		HARVEY						MAGNESIA								
Date	400 HAR. TANK		PRV-3		STORE/CAFÉ		LIONS BAY AVE.		KELVIN GROVE		100 MAG. TANK		PRV-5		BRUNSWICK B.	
	Turbidity (NTU)	CL2 Res. (ppm)	Turbidity (NTU)	CL2 Res. (ppm)	Turbidity (NTU)	CL2 Res. (ppm)	Turbidity (NTU)	CL2 Res. (ppm)	Turbidity (NTU)	CL2 Res. (ppm)	Turbidity (NTU)	CL2 Res. (ppm)	Turbidity (NTU)	CL2 Res. (ppm)	Turbidity (NTU)	CL2 Res. (ppm)
1	0.32	0.91	0.47	0.87	0.34	0.68	0.41	0.52	0.37	0.36	0.67	1.08	0.52	0.86	0.42	0.25
2	0.88	1.02	0.51	0.99	0.48	0.74	0.46	0.71	0.35	0.61	1.09	1.07	0.30	0.88	0.29	0.41
3	0.59	1.08	0.82	1.05	0.60	0.83	0.52	0.73	0.45	0.65	1.08	1.26	0.67	0.97	0.36	0.50
4	0.71	1.08	0.63	1.05	0.49	0.94	0.37	0.80	0.27	0.87	0.71	1.26	0.26	1.00	0.22	0.49
5	1.94	1.06	1.05	1.03	0.71	0.83	1.17	0.86	0.24	0.79	1.48	1.29	1.07	0.96	0.35	0.52
6																
7																
8																
9	0.23	0.97	0.32	0.93	0.26	0.73	0.19	0.69	0.18	0.41	0.65	1.17	0.57	0.85	0.21	0.48
10	0.42	0.91	0.46	0.88	0.25	0.68	0.82	0.72	0.39	0.57	0.37	1.23	0.30	1.21	0.22	0.45
11	1.01	0.83	0.41	0.79	0.48	0.61	0.87	0.71	0.19	0.58	0.90	1.07	0.44	1.10	0.18	0.53
12	0.98	0.95	1.44	0.84	0.64	0.75	0.59	0.69	0.29	0.58	0.57	1.09	0.48	1.05	0.71	0.87
13																
14																
15	0.20	0.92	0.28	0.89	0.19	0.63	0.23	0.65	0.17	0.44	1.42	1.00	0.39	1.01	0.35	0.75
16	3.03	0.88	0.51	0.85	0.57	0.64	0.37	0.61	0.28	0.58	0.69	0.86	0.53	0.85	0.46	0.62
17	0.31	0.86	0.34	0.82	0.34	0.63	0.32	0.68	0.57	0.47	0.51	0.73	0.64	0.62	0.31	0.71
18	2.18	0.96	1.27	0.94	0.51	0.66	0.84	0.74	0.45	0.54	0.38	0.74	0.30	0.66	0.36	0.70
19	3.13	0.84	1.36	0.81	0.96	0.61	0.80	0.73	0.47	0.73	0.61	0.72	0.88	0.69	0.30	0.53
20																
21																
22	0.35	0.91	0.25	0.87	0.17	0.61	0.16	0.72	0.29	0.26	0.29	0.96	0.29	0.95	0.26	0.48
23	0.21	0.93	0.29	0.90	0.24	0.69	0.20	0.81	0.21	0.54	0.40	1.13	0.35	1.06	0.42	0.68
24	4.06	1.03	0.68	1.00	0.77	0.72	0.54	0.86	0.66	0.52	0.29	1.10	0.24	1.04	0.35	0.72
25	0.57	1.01	0.23	0.98	0.31	0.82	0.35	0.90	0.25	0.62	0.29	1.09	0.32	1.04	0.29	0.79
26	1.21	1.04	2.09	1.02	0.80	0.85	0.41	0.94	0.40	0.91	1.11	1.05	0.64	1.05	0.41	0.89
27																
28																
29	0.36	0.91	0.32	0.87	0.26	0.65	0.25	0.84	0.18	0.66	0.41	0.98	0.21	0.91	0.29	0.77

# APPENDIX B: SOURCE & DISTRIBUTION WATER TESTING RESULTS

## Village of Lions Bay Distribution System NTU and Cl<sup>2</sup> Results

Date		TREATED WATER MARCH 2016															
		HARVEY						MAGNESIA									
		400 HAR. TANK		PRV-3		STORE/CAFÉ		LIONS BAY AVE.		KELVIN GROVE		100 MAG. TANK		PRV-5		BRUNSWICK B.	
Turbidity (NTU)	CL2 Res. (ppm)	Turbidity (NTU)	CL2 Res. (ppm)	Turbidity (NTU)	CL2 Res. (ppm)	Turbidity (NTU)	CL2 Res. (ppm)	Turbidity (NTU)	CL2 Res. (ppm)	Turbidity (NTU)	CL2 Res. (ppm)	Turbidity (NTU)	CL2 Res. (ppm)	Turbidity (NTU)	CL2 Res. (ppm)	Turbidity (NTU)	CL2 Res. (ppm)
1	0.62	0.94	0.75	0.91	0.27	0.68	1.05	0.72	0.19	0.81	0.31	0.88	0.49	0.89	0.37	0.83	
2	3.61	0.81	2.41	0.77	1.16	0.57	1.26	0.69	0.19	0.54	0.64	0.77	0.28	0.75	0.45	0.78	
3	0.78	0.78	1.03	0.74	0.32	0.52	0.66	0.57	0.21	0.61	0.59	0.77	0.54	0.62	0.32	0.72	
4	0.41	0.84	0.67	0.89	0.26	0.57	0.31	0.55	0.22	0.50	0.35	0.67	0.31	0.60	0.23	0.60	
5																	
6																	
7	0.30	1.04	0.27	1.02	0.23	0.73	0.40	0.66	0.25	0.31	0.36	0.75	0.56	0.67	0.24	0.39	
8	2.03	0.81	0.85	0.77	1.36	0.74	0.49	0.73	0.50	0.73	0.87	0.86	0.38	0.74	0.43	0.45	
9	0.48	1.04	0.73	1.01	0.30	0.76	0.25	0.71	0.24	0.75	2.97	0.99	0.43	0.90	0.40	0.47	
10	0.44	0.91	0.61	0.87	0.27	0.82	0.20	0.78	0.21	0.69	0.69	1.02	0.41	0.93	0.31	0.44	
11	2.36	0.85	1.12	0.82	0.98	0.65	0.63	0.74	0.22	0.66	1.12	0.89	0.78	0.83	0.53	0.61	
12																	
13																	
14	1.19	0.98	0.41	0.95	0.42	0.72	0.28	0.72	0.23	0.43	0.72	1.00	0.54	0.93	0.54	0.59	
15	1.53	1.00	1.16	0.97	0.64	0.75	0.68	0.74	0.40	0.60	0.76	0.99	0.49	0.92	0.49	0.69	
16	3.94	1.03	0.47	0.99	0.59	0.86	0.84	0.79	0.22	0.53	0.80	1.01	0.92	0.91	0.49	0.75	
17	1.44	0.99	0.51	0.96	0.56	0.81	0.23	0.80	0.22	0.67	0.43	0.96	0.42	0.92	0.40	0.71	
18	1.18	0.98	0.95	0.95	0.29	0.73	0.24	0.79	0.31	0.66	0.47	0.97	0.36	0.89	0.60	0.73	
19																	
20																	
21	0.31	0.99	0.28	0.95	0.33	0.81	0.21	0.79	0.57	0.76	0.33	0.92	0.32	0.85	0.39	0.88	
22	0.51	0.82	0.95	0.78	0.58	0.64	0.46	0.77	0.24	0.85	0.86	0.91	0.47	0.89	0.66	0.68	
23	0.87	0.84	0.85	0.80	0.67	0.62	0.39	0.67	0.85	0.66	0.20	0.91	0.87	0.83	0.78	0.67	
24	0.33	0.80	0.22	0.71	0.19	0.54	0.18	0.54	0.17	0.51	0.24	0.94	0.23	0.84	0.37	0.67	
25																	
26																	
27	0.28	0.68	0.22	0.72	0.21	0.61	0.20	0.50	0.29	0.34	0.22	1.12	0.19	0.99	0.22	0.72	
28																	
29	0.18	0.80	0.30	0.76	0.17	0.68	0.16	0.59	0.14	0.46	0.63	1.13	0.26	1.07	0.24	0.83	
30	0.48	0.85	0.30	0.82	0.34	0.68	0.31	0.57	0.26	0.56	0.43	1.02	0.46	0.95	0.30	0.86	
31	0.22	0.93	0.31	0.89	0.26	0.78	0.18	0.68	0.64	0.75	0.40	0.96	0.29	0.89	0.55	0.88	

# APPENDIX B: SOURCE & DISTRIBUTION WATER TESTING RESULTS

## Village of Lions Bay Distribution System NTU and CL<sup>2</sup> Results

Date		TREATED WATER APRIL 2016																
		HARVEY						MAGNESIA										
		400 HAR. TANK		PRV-3		STORE/CAFÉ		LIONS BAY AVE.		KELVIN GROVE		100 MAG. TANK		PRV-5		BRUNSWICK B.		
Turbidity (NTU)	CL2 Res. (ppm)	Turbidity (NTU)	CL2 Res. (ppm)	Turbidity (NTU)	CL2 Res. (ppm)	Turbidity (NTU)	CL2 Res. (ppm)	Turbidity (NTU)	CL2 Res. (ppm)	Turbidity (NTU)	CL2 Res. (ppm)	Turbidity (NTU)	CL2 Res. (ppm)	Turbidity (NTU)	CL2 Res. (ppm)	Turbidity (NTU)	CL2 Res. (ppm)	
1	1.27	0.90	1.20	0.69	2.55	0.75	0.81	0.69	0.28	0.69	0.60	0.91	0.69	0.87	0.49	0.83		
2																		
3																		
4	0.34	0.95	0.25	0.91	0.20	0.83	0.80	0.23	0.22	0.63	0.42	0.71	0.39	0.67	0.25	0.52		
5	0.30	0.99	0.24	0.96	0.39	0.76	0.77	0.19	0.25	0.64	0.29	0.83	0.25	0.69	0.31	0.50		
6	1.09	1.03	0.54	0.99	0.32	0.79	0.69	0.30	0.21	0.70	0.45	0.93	0.51	0.83	0.35	0.49		
7	1.79	0.92	0.51	0.88	0.27	0.76	0.73	0.21	0.21	0.81	0.30	0.98	0.31	0.89	0.35	0.63		
8	1.66	0.93	1.00	0.90	0.36	0.79	0.77	0.31	0.18	0.89	0.34	1.08	0.48	0.97	0.46	0.66		
9																		
10																		
11	0.20	0.95	0.21	0.92	0.19	0.77	0.69	0.32	0.19	0.73	0.30	1.12	0.26	1.04	0.35	0.92		
12	0.18	0.96	0.31	0.88	0.25	0.77	0.68	0.15	0.24	0.63	0.32	1.21	0.24	1.11	0.23	0.86		
13	0.23	0.97	0.22	0.90	0.79	0.78	0.65	0.14	0.27	0.55	0.28	1.09	0.23	1.00	0.22	0.82		
14	0.21	0.96	0.20	1.00	0.19	0.80	0.57	0.19	0.17	0.62	0.20	1.10	0.18	1.05	0.22	0.88		
15	0.18	1.01	0.17	0.95	0.20	0.80	0.61	0.13	0.17	0.63	0.18	1.09	0.17	1.00	0.21	0.80		
16																		
17																		
18	0.17	1.02	0.35	0.98	0.22	0.82	0.85	0.19	0.23	0.69	0.25	0.89	0.16	0.84	0.22	0.83		
19	0.24	0.84	0.53	0.80	0.24	0.71	0.76	0.38	0.48	0.88	0.30	0.94	0.29	0.89	0.31	0.73		
20	0.25	0.92	0.22	0.82	0.15	0.63	0.73	0.11	1.91	0.66	0.24	0.94	0.21	0.89	0.34	0.77		
21	0.27	0.84	0.36	0.81	0.33	0.60	0.64	0.20	0.77	0.61	0.42	0.90	0.27	0.81	0.24	0.73		
22	0.64	0.74	0.58	0.71	0.25	0.52	0.53	0.21	0.63	0.47	0.39	0.84	0.27	0.74	0.31	0.75		
23																		
24																		
25	0.23	0.86	0.57	0.83	0.20	0.60	0.41	0.16	0.25	0.30	0.32	0.93	0.24	0.77	0.25	0.55		
26	0.22	1.03	0.28	1.00	0.30	0.74	0.61	0.20	0.24	0.88	0.35	0.91	0.24	0.84	0.31	0.59		
27	0.24	1.09	0.41	1.05	0.31	0.86	0.92	0.23	0.20	0.69	0.35	0.94	0.26	0.84	0.29	0.60		
28	0.21	1.11	0.31	1.07	0.20	0.85	0.84	0.16	0.24	0.74	0.31	0.97	0.21	0.92	0.29	0.59		
29	0.25	1.00	0.35	0.97	0.33	0.51	0.89	0.16	0.43	0.83	0.32	1.01	0.21	0.93	0.22	0.81		
30																		

# APPENDIX B: SOURCE & DISTRIBUTION WATER TESTING RESULTS

## Village of Lions Bay Distribution System NTU and CL<sup>2</sup> Results

Date		TREATED WATER MAY 2016																
		HARVEY							MAGNESIA									
		400 HAR. TANK		PRV-3		STORE/CAFÉ		LIONS BAY AVE.		KELVIN GROVE		100 MAG. TANK		PRV-5		BRUNSWICK B.		
Turbidity (NTU)	CL2 Res. (ppm)	Turbidity (NTU)	CL2 Res. (ppm)	Turbidity (NTU)	CL2 Res. (ppm)	Turbidity (NTU)	CL2 Res. (ppm)	Turbidity (NTU)	CL2 Res. (ppm)	Turbidity (NTU)	CL2 Res. (ppm)	Turbidity (NTU)	CL2 Res. (ppm)	Turbidity (NTU)	CL2 Res. (ppm)	Turbidity (NTU)	CL2 Res. (ppm)	
1																		
2	0.21	0.87	0.26	0.84	0.32	0.52	0.22	0.78	0.28	0.62	0.18	0.89	0.18	0.87	0.24	0.76		
3	1.35	0.84	0.37	0.80	0.22	0.57	0.24	0.68	0.52	0.64	0.31	0.96	0.21	0.89	0.24	0.79		
4	0.34	0.64	0.24	0.60	0.27	0.45	0.21	0.59	0.19	0.47	0.32	0.95	0.28	0.87	0.28	0.75		
5	0.22	0.78	0.42	0.74	0.20	0.56	0.21	0.52	0.21	0.38	0.32	0.97	0.20	0.85	0.21	0.75		
6	0.27	0.93	0.27	0.89	0.65	0.62	0.20	0.53	0.15	0.38	0.24	0.95	0.18	0.85	0.26	0.74		
7																		
8																		
9	0.15	1.05	0.18	1.02	0.24	0.60	0.25	0.89	0.19	0.53	0.22	1.00	0.19	0.97	0.23	0.75		
10	0.20	1.04	0.24	1.01	0.20	0.77	0.27	0.91	0.20	0.54	0.23	0.96	0.17	0.89	0.20	0.74		
11	0.11	1.03	0.11	1.01	0.15	0.66	0.14	0.82	0.14	0.81	0.16	0.88	0.13	0.81	0.16	0.75		
12	0.15	0.95	0.30	0.92	0.29	0.77	0.16	0.76	0.25	0.56	0.24	0.79	0.17	0.67	0.29	0.64		
13	0.21	0.96	0.26	0.93	0.44	0.65	0.16	0.75	0.19	0.64	0.49	0.87	0.44	0.82	0.72	0.62		
14																		
15																		
16	0.19	0.90	0.30	0.86	0.45	0.58	0.23	0.71	0.15	0.49	0.23	1.01	0.26	0.91	0.34	0.63		
17	0.25	0.93	0.20	0.84	0.20	0.71	0.17	0.73	0.23	0.46	0.50	1.08	0.23	0.91	0.37	1.04		
18	0.34	0.88	0.21	0.84	0.27	0.69	0.24	0.79	0.18	0.43	0.26	1.04	0.36	0.95	0.34	0.82		
19	0.41	0.91	0.17	0.87	0.13	0.70	0.17	0.70	0.29	0.46	0.26	0.96	0.28	0.95	0.21	0.85		
20	0.19	0.90	0.16	0.85	0.28	0.63	0.19	0.65	0.17	0.51	0.21	0.96	0.20	0.87	0.26	0.75		
21																		
22																		
23																		
24	0.21	0.89	0.20	0.85	0.18	0.68	0.12	0.72	0.18	0.41	0.24	0.87	0.24	0.84	0.28	0.73		
25	0.20	0.93	0.27	0.88	0.20	0.72	0.37	0.80	0.16	0.58	0.14	0.82	0.23	0.76	0.20	0.69		
26	0.27	0.92	0.62	0.88	0.31	0.75	0.18	0.72	0.19	0.60	0.53	0.71	0.26	0.68	0.26	0.68		
27	0.19	0.87	0.30	0.83	0.25	0.71	0.16	0.71	0.14	0.53	0.18	0.68	0.24	0.62	0.21	0.56		
28																		
29																		
30	0.34	0.70	0.36	0.59	0.33	0.46	0.14	0.40	0.21	0.21	0.28	0.55	0.35	0.49	0.16	0.45		
31	0.25	0.76	0.23	0.72	0.30	0.53	0.17	0.40	0.18	0.20	0.20	0.55	0.19	0.62	0.19	0.29		

# APPENDIX B: SOURCE & DISTRIBUTION WATER TESTING RESULTS

## Village of Lions Bay Distribution System NTU and CL<sup>2</sup> Results

Date		TREATED WATER JUNE 2016															
		HARVEY						MAGNESIA									
		400 HAR. TANK		PRV-3		STORE/CAFÉ		LIONS BAY AVE.		KELVIN GROVE		100 MAG. TANK		PRV-5		BRUNSWICK B.	
Turbidity (NTU)	CL2 Res. (ppm)	Turbidity (NTU)	CL2 Res. (ppm)	Turbidity (NTU)	CL2 Res. (ppm)	Turbidity (NTU)	CL2 Res. (ppm)	Turbidity (NTU)	CL2 Res. (ppm)	Turbidity (NTU)	CL2 Res. (ppm)	Turbidity (NTU)	CL2 Res. (ppm)	Turbidity (NTU)	CL2 Res. (ppm)	Turbidity (NTU)	CL2 Res. (ppm)
1	0.56	0.87	0.76	0.82	0.66	0.57	0.42	0.18	0.42	0.20	0.29	0.27	0.67	0.40	0.70	0.21	0.34
2	0.23	0.78	0.26	0.77	0.28	0.60	0.55	0.16	0.36	0.40	0.36	0.56	0.59	0.27	0.74	0.45	0.47
3	0.23	0.87	0.47	0.83	0.28	0.58	0.57	0.15	0.40	0.28	0.40	0.25	0.68	0.18	0.70	0.29	0.41
4																	
5																	
6	0.26	0.87	0.35	0.82	0.23	0.57	0.70	0.20	0.42	0.21	0.42	0.35	0.64	0.26	0.76	0.16	0.42
7	0.21	0.91	0.27	0.87	0.26	0.66	0.70	0.22	0.42	0.27	0.42	0.32	0.73	0.19	0.78	0.14	0.55
8	0.36	0.90	0.15	0.87	0.39	0.59	0.79	0.24	0.41	0.20	0.41	0.27	0.78	0.26	0.78	0.24	0.53
9	0.23	0.88	0.27	0.84	0.20	0.67	0.63	0.20	0.46	0.17	0.46	0.21	0.95	0.26	0.79	0.18	0.53
10	0.32	0.94	0.29	0.92	0.24	0.69	0.76	0.24	0.51	0.27	0.51	0.27	1.07	0.32	0.96	0.40	0.62
11																	
12																	
13	0.17	0.84	0.29	0.80	0.44	0.58	0.55	0.16	0.42	0.19	0.42	0.18	1.04	0.18	0.98	0.17	0.81
14	0.15	0.87	0.34	0.85	0.21	0.57	0.54	0.20	0.41	0.30	0.41	0.37	1.09	0.71	0.99	0.18	0.85
15	0.20	0.78	0.44	0.76	0.19	0.59	0.51	0.16	0.48	0.17	0.48	0.31	1.06	0.25	1.04	0.18	0.88
16	0.25	0.71	0.54	0.67	0.23	0.48	0.52	0.14	0.47	0.14	0.47	0.20	1.02	0.18	0.98	0.17	0.82
17	0.21	0.69	0.31	0.67	0.20	0.44	0.41	0.15	0.32	0.13	0.32	0.33	1.08	0.22	1.03	0.21	0.80
18																	
19																	
20	0.18	0.74	0.20	0.70	0.23	0.45	0.54	0.20	0.23	0.14	0.23	0.43	1.02	0.22	0.93	0.21	0.80
21	0.14	0.72	0.48	0.68	0.19	0.55	0.51	0.17	0.42	0.14	0.42	0.22	1.01	0.25	0.91	0.20	0.78
22	0.18	0.73	0.39	0.69	0.30	0.47	0.58	0.25	0.30	0.14	0.30	0.25	1.01	0.17	0.96	0.17	0.77
23	0.16	0.81	0.32	0.76	0.24	0.60	0.56	0.21	0.32	0.18	0.32	0.39	1.06	0.23	1.00	0.20	0.79
24	0.50	0.67	0.54	0.63	0.28	0.43	0.53	0.31	0.39	0.15	0.39	0.43	1.01	0.32	0.94	0.30	0.78
25																	
26																	
27	0.22	0.65	0.22	0.73	0.26	0.54	0.56	0.24	0.48	0.42	0.48	0.33	1.03	0.31	0.93	0.29	0.64
28	0.20	0.66	0.24	0.60	0.23	0.43	0.36	0.24	0.73	0.18	0.73	0.17	0.90	0.25	0.81	0.27	0.65
29	0.16	0.91	0.22	0.74	0.34	0.37	0.49	0.38	0.42	1.67	0.42	0.38	0.81	0.40	0.58	0.26	0.69
30	0.20	0.75	0.27	0.81	0.22	0.34	0.56	0.23	0.49	0.58	0.49	0.27	0.74	0.25	0.72	0.34	0.51

# APPENDIX B: SOURCE & DISTRIBUTION WATER TESTING RESULTS

## Village of Lions Bay Distribution System NTU and CL<sup>2</sup> Results

Date		TREATED WATER JULY 2016																
		HARVEY							MAGNESIA									
		400 HAR. TANK		PRV-3		STORE/CAFÉ		LIONS BAY AVE.		KELVIN GROVE		100 MAG. TANK		PRV-5		BRUNSWICK B.		
Turbidity (NTU)	CL2 Res. (ppm)	Turbidity (NTU)	CL2 Res. (ppm)	Turbidity (NTU)	CL2 Res. (ppm)	Turbidity (NTU)	CL2 Res. (ppm)	Turbidity (NTU)	CL2 Res. (ppm)	Turbidity (NTU)	CL2 Res. (ppm)	Turbidity (NTU)	CL2 Res. (ppm)	Turbidity (NTU)	CL2 Res. (ppm)	Turbidity (NTU)	CL2 Res. (ppm)	
1																		
2																		
3																		
4	0.22	0.90	0.24	0.87	0.19	0.72	0.76	0.18	0.76	0.19	0.37	0.25	0.89	0.19	0.90	0.24	0.75	
5	0.19	0.82	0.33	0.79	0.42	0.66	0.70	0.15	0.70	0.18	0.51	0.29	0.89	0.17	0.85	0.21	0.69	
6	0.15	0.93	0.18	0.89	0.20	0.72	0.76	0.17	0.76	0.24	0.49	0.43	0.92	0.18	0.91	0.24	0.64	
7	0.15	0.88	0.24	0.85	0.22	0.67	0.74	0.13	0.74	0.19	0.52	0.20	0.96	0.37	0.89	0.20	0.71	
8	0.51	0.73	0.27	0.70	0.27	0.61	0.69	0.19	0.69	0.20	0.54	0.42	0.90	0.30	0.86	0.32	0.68	
9																		
10																		
11	0.46	0.61	0.48	0.56	0.27	0.26	0.23	0.26	0.23	0.68	0.46	0.43	0.67	0.35	0.56	0.33	0.30	
12	1.18	0.74	1.61	0.71	0.25	0.40	0.21	0.22	0.21	0.20	0.37	0.54	1.03	0.28	0.93	0.34	0.20	
13	0.51	0.87	0.76	0.83	0.25	0.54	0.51	0.27	0.51	0.19	0.27	0.60	1.07	0.33	1.09	0.26	0.47	
14	1.49	0.98	0.50	0.95	0.22	0.73	0.64	0.23	0.64	0.30	0.42	0.25	1.01	0.22	1.00	0.25	0.71	
15	1.06	0.90	0.44	0.86	0.31	0.55	0.79	0.20	0.79	0.20	0.37	0.29	0.87	0.21	0.86	0.22	0.72	
16																		
17																		
18	0.24	1.07	0.22	1.04	0.22	0.66	0.93	0.18	0.93	0.17	0.48	0.43	0.92	0.20	0.85	0.19	0.55	
19	1.40	0.98	0.51	0.96	0.19	0.75	0.88	0.35	0.88	0.17	0.55	0.31	0.92	0.22	0.89	0.31	0.57	
20	1.73	0.89	0.56	0.85	0.22	0.68	0.78	0.17	0.78	0.18	0.53	0.28	0.88	0.24	0.84	0.24	0.66	
21	0.20	0.90	0.33	0.87	0.16	0.71	0.72	0.22	0.72	0.15	0.44	0.64	0.92	0.25	0.88	0.25	0.63	
22	0.17	0.79	0.27	0.75	0.22	0.69	0.67	0.21	0.67	0.23	0.43	0.27	0.88	0.23	0.88	0.27	0.67	
23																		
24																		
25	0.25	0.85	0.18	0.81	0.28	0.64	0.71	0.20	0.71	0.30	0.40	0.17	0.91	0.15	0.86	0.19	0.70	
26	0.21	0.83	0.29	0.79	0.19	0.63	0.68	0.13	0.68	0.17	0.45	0.24	0.89	0.15	0.89	0.17	0.76	
27	0.16	0.84	0.33	0.81	0.63	0.59	0.74	0.23	0.74	0.21	0.44	1.11	0.76	0.81	0.73	0.31	0.68	
28	0.74	0.89	0.19	0.85	0.16	0.63	0.69	0.16	0.69	0.17	0.47	0.75	0.90	0.62	0.86	0.95	0.54	
29	0.77	0.83	0.20	0.80	0.25	0.68	0.71	0.21	0.71	0.17	0.43	0.40	0.99	0.29	0.95	0.48	0.70	
30																		
31																		

# APPENDIX B: SOURCE & DISTRIBUTION WATER TESTING RESULTS

## Village of Lions Bay Distribution System NTU and CL<sup>2</sup> Results

Date	TREATED WATER AUGUST 2016															
	HARVEY							MAGNESIA								
	400 HAR. TANK		PRV-3		STORE/CAFÉ		LIONS BAY AVE.		KELVIN GROVE		100 MAG. TANK		PRV-5		BRUNSWICK B.	
	Turbidity (NTU)	CL2 Res. (ppm)	Turbidity (NTU)	CL2 Res. (ppm)	Turbidity (NTU)	CL2 Res. (ppm)	Turbidity (NTU)	CL2 Res. (ppm)	Turbidity (NTU)	CL2 Res. (ppm)	Turbidity (NTU)	CL2 Res. (ppm)	Turbidity (NTU)	CL2 Res. (ppm)	Turbidity (NTU)	CL2 Res. (ppm)
1																
2	0.31	0.82	0.21	0.79	0.15	0.65	0.13	0.67	0.13	0.36	0.21	1.08	0.23	1.09	0.22	0.81
3	0.18	0.76	0.21	0.72	0.18	0.66	0.16	0.68	0.16	0.45	0.31	1.00	0.21	1.04	0.27	0.81
4	0.20	0.84	0.26	0.80	0.20	0.60	0.18	0.62	0.25	0.46	0.24	0.95	0.23	0.92	0.29	0.77
5	0.57	0.84	0.17	0.81	0.18	0.60	0.14	0.62	0.15	0.46	0.25	0.88	0.19	0.81	0.41	0.71
6																
7																
8	0.30	0.88	0.34	0.85	0.29	0.62	0.14	0.75	0.15	0.46	0.34	0.79	0.21	0.80	0.68	0.68
9	0.17	0.90	0.28	0.86	0.22	0.66	0.17	0.71	0.16	0.52	0.26	0.75	0.17	0.77	0.59	0.57
10	0.75	0.88	0.33	0.85	0.20	0.68	0.22	0.78	0.26	0.56	0.38	0.79	0.21	0.77	0.26	0.60
11	0.30	0.85	0.28	0.79	0.25	0.77	0.16	0.70	0.34	0.64	0.30	0.90	0.29	0.80	0.33	0.53
12	0.51	0.90	0.54	0.86	0.29	0.72	0.22	0.71	0.21	0.60	0.26	0.88	0.26	0.85	0.25	0.63
13																
14																
15	0.25	0.89	0.16	0.85	0.16	0.68	0.16	0.74	0.15	0.58	0.22	0.90	0.19	0.86	0.27	0.72
16	0.18	0.80	0.14	0.77	0.16	0.60	0.13	0.69	0.30	0.54	0.17	1.02	0.30	0.90	0.30	0.75
17	0.17	0.84	0.21	0.81	0.14	0.66	0.20	0.74	0.16	0.53	0.20	1.01	0.22	1.01	0.28	0.75
18	0.17	0.95	0.17	0.93	0.19	0.66	0.16	0.70	0.15	0.53	0.26	0.83	0.18	0.85	0.22	0.82
19	0.16	1.09	0.27	1.06	0.18	0.87	0.13	0.85	0.14	0.73	0.28	0.85	0.22	0.80	0.27	0.75
20																
21																
22	0.15	0.97	0.24	0.93	0.20	0.76	0.29	0.83	0.15	0.64	0.19	0.71	0.16	0.70	0.22	0.63
23	0.12	0.94	0.18	0.90	0.15	0.72	0.13	0.78	0.15	0.67	0.20	0.70	0.23	0.63	0.22	0.55
24	0.11	0.90	0.33	0.87	0.22	0.76	0.13	0.77	0.13	0.62	0.22	0.78	0.15	0.76	0.25	0.53
25	0.12	0.96	0.18	0.93	0.13	0.75	0.20	0.78	0.13	0.66	0.16	0.81	0.20	0.77	0.19	0.61
26	0.17	0.88	0.13	0.85	0.19	0.71	0.12	0.80	0.13	0.62	0.24	0.82	0.21	0.76	0.30	0.57
27																
28																
29	0.23	0.78	0.18	0.74	0.17	0.60	0.12	0.71	0.13	0.50	0.19	0.79	0.21	0.75	0.29	0.51
30	0.16	0.81	0.53	0.77	0.44	0.69	0.13	0.63	0.15	0.54	0.23	0.85	0.27	0.77	0.28	0.55
31	0.17	0.87	0.17	0.84	0.34	0.68	0.18	0.73	0.15	0.51	0.17	0.86	0.17	0.91	0.26	0.55

# APPENDIX B: SOURCE & DISTRIBUTION WATER TESTING RESULTS

## Village of Lions Bay Distribution System NTU and CL<sup>2</sup> Results

Date		TREATED WATER SEPTEMBER 2016																
		HARVEY						MAGNESIA										
		400 HAR. TANK		PRV-3		STORE/CAFÉ		LIONS BAY AVE.		KELVIN GROVE		100 MAG. TANK		PRV-5		BRUNSWICK B.		
Turbidity (NTU)	CL2 Res. (ppm)	Turbidity (NTU)	CL2 Res. (ppm)	Turbidity (NTU)	CL2 Res. (ppm)	Turbidity (NTU)	CL2 Res. (ppm)	Turbidity (NTU)	CL2 Res. (ppm)	Turbidity (NTU)	CL2 Res. (ppm)	Turbidity (NTU)	CL2 Res. (ppm)	Turbidity (NTU)	CL2 Res. (ppm)	Turbidity (NTU)	CL2 Res. (ppm)	
1	0.30	0.87	0.44	0.83	0.23	0.63	0.15	0.69	0.16	0.52	0.30	0.90	0.19	0.80	0.27	0.59		
2	0.18	0.75	0.28	0.72	0.19	0.59	0.15	0.64	0.17	0.47	0.30	0.92	0.17	0.83	0.30	0.55		
3																		
4																		
5																		
6	0.16	0.80	0.18	0.76	0.38	0.62	0.14	0.47	0.13	0.21	0.17	0.96	0.29	0.87	0.20	0.61		
7	0.18	0.84	0.24	0.81	0.23	0.60	0.15	0.59	0.13	0.47	0.33	0.93	0.16	0.88	0.21	0.65		
8	0.22	0.82	0.22	0.79	0.32	0.70	0.20	0.56	0.15	0.63	0.17	0.86	0.17	0.82	0.27	0.65		
9	0.17	0.94	0.18	0.89	0.18	0.71	0.13	0.62	0.29	0.50	0.14	0.87	0.17	0.81	0.20	0.63		
10																		
11																		
12	0.15	1.12	0.18	1.10	0.15	0.85	0.12	0.91	0.13	0.55	0.14	0.88	0.14	0.84	0.23	0.61		
13	0.15	1.03	0.32	1.01	0.18	0.93	0.14	0.92	0.18	0.69	0.14	0.93	0.41	0.87	0.21	0.67		
14	0.14	1.08	0.17	1.05	0.25	0.86	0.15	0.94	0.14	0.80	0.17	1.00	0.84	0.95	0.37	0.75		
15	0.13	1.02	0.15	0.99	0.15	0.88	0.16	0.94	0.16	0.76	0.20	0.97	0.15	0.94	0.45	0.74		
16	0.18	1.00	0.19	0.97	0.43	0.83	0.18	0.86	0.16	0.79	0.23	0.93	0.19	0.90	0.26	0.80		
17																		
18																		
19	0.17	0.86	0.24	0.81	0.16	0.67	0.18	0.66	0.15	0.46	0.18	0.96	0.17	0.90	0.23	0.69		
20	0.25	0.75	0.19	0.72	0.18	0.58	0.14	0.52	0.15	0.37	0.22	0.87	0.22	0.85	0.30	0.63		
21	0.21	0.88	0.24	0.85	0.21	0.64	0.15	0.53	0.14	0.35	0.21	0.85	0.25	0.84	0.22	0.64		
22	0.14	0.92	0.34	0.89	0.30	0.74	0.15	0.62	3.88	0.44	0.36	0.91	0.41	0.86	0.28	0.57		
23	0.32	1.09	0.19	1.07	0.41	0.76	0.17	0.68	0.74	0.66	0.30	0.93	0.35	0.91	0.35	0.63		
24																		
25																		
26	0.17	0.74	0.19	0.70	0.24	0.54	0.22	0.50	0.18	0.23	0.23	0.79	0.17	0.74	0.22	0.57		
27	0.19	0.79	0.20	0.76	0.15	0.58	0.18	0.42	0.16	0.32	0.20	0.82	0.17	0.72	0.26	0.50		
28	0.20	0.84	0.18	0.80	0.18	0.66	0.16	0.53	0.15	0.27	0.37	0.92	0.18	0.98	0.53	0.53		
29	0.24	0.85	0.17	0.82	0.17	0.72	0.15	0.65	0.15	0.41	0.23	0.95	0.19	0.91	0.27	0.50		
30	0.15	0.93	0.17	0.90	0.20	0.80	0.18	0.68	0.16	0.47	0.35	0.98	0.16	0.98	0.31	0.62		

# APPENDIX B: SOURCE & DISTRIBUTION WATER TESTING RESULTS

## Village of Lions Bay Distribution System NTU and CL<sup>2</sup> Results

Date		TREATED WATER OCTOBER 2016																
		HARVEY						MAGNESIA										
		400 HAR. TANK		PRV-3		STORE/CAFÉ		LIONS BAY AVE.		KELVIN GROVE		100 MAG. TANK		PRV-5		BRUNSWICK B.		
Turbidity (NTU)	CL2 Res. (ppm)	Turbidity (NTU)	CL2 Res. (ppm)	Turbidity (NTU)	CL2 Res. (ppm)	Turbidity (NTU)	CL2 Res. (ppm)	Turbidity (NTU)	CL2 Res. (ppm)	Turbidity (NTU)	CL2 Res. (ppm)	Turbidity (NTU)	CL2 Res. (ppm)	Turbidity (NTU)	CL2 Res. (ppm)	Turbidity (NTU)	CL2 Res. (ppm)	
1																		
2																		
3	0.16	0.94	0.21	0.91	0.18	0.84	0.19	0.75	0.18	0.55	0.21	0.97	0.25	0.98	0.23	0.73		
4	0.23	0.88	0.27	0.85	0.23	0.73	0.16	0.66	0.22	0.42	0.19	0.96	0.19	0.94	0.27	0.72		
5	0.46	0.52	0.67	0.48	0.23	0.37	0.22	0.63	0.15	0.35	0.29	0.82	0.22	0.86	0.28	0.70		
6	0.62	0.49	0.53	0.43	0.26	0.20	0.27	0.35	0.23	0.34	0.54	0.66	0.35	0.59	0.28	0.69		
7	0.66	0.54	1.10	0.46	0.34	0.77	0.23	0.23	0.22	0.76	1.86	0.60	0.34	0.64	0.35	0.51		
8																		
9																		
10																		
11	3.01	0.72	0.69	0.68	0.61	0.45	0.54	0.37	0.36	0.42	0.76	0.84	0.60	0.78	0.67	0.40		
12	0.47	0.79	0.41	0.75	0.37	0.52	0.33	0.30	0.24	0.27	0.51	0.92	0.47	0.85	0.61	0.56		
13	0.46	0.91	0.38	0.88	0.30	0.70	0.30	0.37	0.28	0.42	0.42	1.09	0.50	1.00	0.42	0.44		
14	0.96	0.8	0.39	0.76	0.32	0.57	0.24	0.44	0.39	0.31	0.56	0.99	0.35	0.95	0.42	0.46		
15																		
16																		
17	1.66	0.65	1.15	0.61	0.87	0.46	2.84	0.22	0.69	0.39	1.57	1.54	0.83	0.54	0.57	0.35		
18	2.09	0.78	1.31	0.75	1.03	0.47	0.91	0.21	3.64	0.71	2.13	0.76	0.77	0.58	1.44	0.28		
19	1.52	0.84	1.19	0.80	0.63	0.59	0.81	0.20	0.51	0.64	2.26	0.62	0.78	0.59	0.98	0.28		
20	1.35	0.94	0.93	0.90	0.55	0.69	0.58	0.23	0.38	0.40	2.06	0.56	0.54	0.78	1.17	0.43		
21	1.18	0.86	0.88	0.83	0.46	0.59	0.67	0.37	0.33	0.49	1.46	0.87	0.47	0.70	0.50	0.61		
22																		
23																		
24	0.42	0.78	0.38	0.74	0.34	0.49	0.39	0.37	0.46	0.58	0.76	0.95	0.27	0.53	0.26	0.50		
25	1.51	0.78	0.71	0.74	0.30	0.47	0.28	0.91	0.22	0.44	0.75	1.02	0.61	0.29	0.24	0.23		
26	1.30	0.75	0.36	0.70	0.53	0.46	0.47	0.30	0.23	0.26	1.22	1.01	0.70	0.93	0.35	0.24		
27	1.46	0.70	0.66	0.66	0.36	0.48	1.68	0.26	0.27	0.42	1.31	0.92	0.29	0.28	0.44	0.64		
28	1.50	0.82	0.81	0.58	0.56	0.43	0.72	0.29	0.35	0.42	1.47	0.93	0.37	0.37	0.84	0.53		
29																		
30																		
31	0.44	0.94	0.41	0.91	0.34	0.68	0.34	0.44	0.36	0.78	0.67	0.98	0.23	0.54	0.51	0.45		

# APPENDIX B: SOURCE & DISTRIBUTION WATER TESTING RESULTS

## Village of Lions Bay Distribution System NTU and CL<sup>2</sup> Results

Date		TREATED WATER NOVEMBER 2016															
		HARVEY						MAGNESIA									
		400 HAR. TANK		PRV-3		STORE/CAFÉ		LIONS BAY AVE.		KELVIN GROVE		100 MAG. TANK		PRV-5		BRUNSWICK B.	
Turbidity (NTU)	CL2 Res. (ppm)	Turbidity (NTU)	CL2 Res. (ppm)	Turbidity (NTU)	CL2 Res. (ppm)	Turbidity (NTU)	CL2 Res. (ppm)	Turbidity (NTU)	CL2 Res. (ppm)	Turbidity (NTU)	CL2 Res. (ppm)	Turbidity (NTU)	CL2 Res. (ppm)	Turbidity (NTU)	CL2 Res. (ppm)	Turbidity (NTU)	CL2 Res. (ppm)
1	1.18	0.87	0.42	0.84	0.23	0.62	0.39	0.28	0.19	0.29	0.69	0.97	0.24	0.57	0.53	0.48	
2	0.91	0.86	0.33	0.83	0.24	0.61	0.35	0.42	0.20	0.24	0.66	0.93	0.22	0.55	0.51	0.53	
3	2.67	0.64	1.38	0.60	0.87	0.40	0.33	0.28	0.21	0.31	0.57	0.90	0.58	0.59	0.41	0.55	
4	0.52	0.87	0.67	0.77	0.55	0.60	0.30	0.24	0.32	0.23	0.59	0.85	0.40	0.59	0.41	0.58	
5																	
6																	
7	0.34	0.83	0.35	0.79	0.31	0.51	0.41	0.27	0.31	0.25	0.56	0.89	0.33	0.70	0.33	0.25	
8	0.98	0.79	0.67	0.75	0.50	0.55	0.38	0.54	0.29	0.28	1.29	0.87	0.48	0.72	0.24	0.23	
9	1.52	1.04	1.47	1.01	0.83	0.70	0.29	0.69	0.21	0.25	1.03	0.79	0.55	0.76	0.31	0.24	
10	1.23	0.96	0.29	0.90	0.27	0.69	0.27	0.39	0.23	0.27	0.80	0.93	0.27	0.86	0.24	0.24	
11																	
12																	
13																	
14	0.47	0.94	0.36	0.90	0.36	0.68	0.49	0.19	0.17	0.35	0.52	1.07	0.21	0.87	0.23	0.50	
15	0.72	0.82	0.41	0.78	0.80	0.53	0.54	0.22	0.23	0.47	0.69	1.04	0.30	0.74	0.18	0.51	
16	0.54	0.95	0.40	0.90	0.31	0.52	0.46	0.21	0.23	0.20	0.54	1.10	0.38	0.73	0.21	0.41	
17	0.40	0.98	0.42	0.94	0.26	0.51	0.40	0.24	0.26	0.46	0.46	1.49	0.30	0.78	0.27	0.34	
18	0.44	1.00	0.40	0.70	0.24	0.60	0.26	0.33	0.18	0.28	0.97	0.93	0.26	0.74	0.26	0.30	
19																	
20																	
21	0.39	0.84	0.43	0.80	0.32	1.05	0.38	0.19	0.17	0.29	0.81	0.62	0.20	0.70	0.36	0.51	
22	1.07	0.75	1.39	0.71	0.36	0.45	0.43	0.20	0.20	0.21	0.66	0.57	0.28	0.57	0.44	0.44	
23	2.20	0.76	0.49	0.71	0.33	0.42	0.39	0.33	0.27	0.25	0.57	0.71	0.26	0.54	0.49	0.29	
24	0.57	0.78	0.42	0.73	0.35	0.41	0.34	0.47	0.28	0.20	0.54	0.94	0.27	0.53	0.37	0.26	
25	1.49	0.84	0.60	0.78	0.30	0.34	0.28	0.25	0.26	0.45	0.70	0.89	0.30	0.49	0.38	0.30	
26																	
27																	
28	0.67	0.93	0.42	0.89	0.23	0.54	0.21	0.25	0.22	0.83	0.48	1.03	0.20	0.58	0.34	0.32	
29	2.04	1.02	0.54	0.97	0.30	0.58	0.20	0.27	0.26	0.43	0.46	1.09	0.23	0.69	0.43	0.57	
30	1.38	1.03	1.45	0.99	0.25	0.59	0.38	0.28	0.51	0.36	0.43	1.10	0.21	0.72	0.45	0.70	

# APPENDIX B: SOURCE & DISTRIBUTION WATER TESTING RESULTS

## Village of Lions Bay Distribution System NTU and CL<sup>2</sup> Results

Date		TREATED WATER DECEMBER 2016															
		HARVEY						MAGNESIA									
		400 HAR. TANK		PRV-3		STORE/CAFÉ		LIONS BAY AVE.		KELVIN GROVE		100 MAG. TANK		PRV-5		BRUNSWICK B.	
Turbidity (NTU)	CL2 Res. (ppm)	Turbidity (NTU)	CL2 Res. (ppm)	Turbidity (NTU)	CL2 Res. (ppm)	Turbidity (NTU)	CL2 Res. (ppm)	Turbidity (NTU)	CL2 Res. (ppm)	Turbidity (NTU)	CL2 Res. (ppm)	Turbidity (NTU)	CL2 Res. (ppm)	Turbidity (NTU)	CL2 Res. (ppm)	Turbidity (NTU)	CL2 Res. (ppm)
1	0.40	0.84	0.43	0.80	0.26	0.63	0.25	0.37	0.18	0.37	0.53	1.08	0.21	0.77	0.96	0.69	0.70
2	0.30	0.87	0.78	0.84	0.28	0.50	0.40	0.31	0.21	0.29	0.84	1.03	0.28	0.68	0.49	0.70	
3																	
4																	
5	0.33	0.81	0.61	0.77	0.21	0.41	0.19	0.32	0.14	0.53	0.41	0.91	0.24	0.56	0.38	0.65	
6	0.37	1.02	0.77	0.98	0.23	0.59	0.32	0.31	0.18	0.35	0.53	0.94	0.18	0.60	0.35	0.66	
7	0.83	1.06	0.33	1.02	0.32	0.55	0.25	0.29	0.17	0.38	0.28	0.90	0.17	0.70	0.36	0.62	
8	0.65	1.04	0.24	1.01	0.37	0.75	0.29	0.42	0.19	1.08	0.45	0.97	0.33	0.86	0.30	0.63	
9	1.00	1.12	0.91	1.08	0.50	0.81	0.25	0.59	0.37	0.68	0.60	0.95	0.23	0.91	0.29	0.67	
10																	
11																	
12	0.16	0.91	0.15	0.87	0.24	0.67	0.16	0.70	0.48	0.54	0.31	0.90	0.23	0.83	0.25	0.72	
13	0.24	0.84	0.22	0.81	0.67	0.63	0.24	0.71	0.15	0.65	0.38	0.84	0.25	0.77	0.30	0.73	
14	0.30	0.78	0.86	0.73	0.39	0.53	0.20	0.65	0.38	0.61	0.27	0.82	0.29	0.68	0.29	0.70	
15	0.24	0.94	0.17	1.01	0.28	0.58	0.18	0.63	0.19	0.53	0.20	0.82	0.14	0.68	0.26	0.69	
16	0.32	1.07	0.20	1.04	0.33	0.73	0.20	0.53	0.31	0.55	N/A	N/A	0.21	0.71	0.29	0.64	
17																	
18																	
19	0.21	1.12	1.15	1.09	0.49	0.87	0.23	0.81	0.14	0.46	0.23	0.84	0.14	0.97	0.35	0.59	
20	0.29	1.13	0.47	1.10	0.51	0.82	0.29	0.83	0.27	0.51	0.32	0.82	0.25	0.99	0.27	0.60	
21	0.99	1.03	0.65	1.01	0.42	0.76	0.33	0.79	0.38	0.93	0.67	0.78	0.18	0.95	0.44	0.61	
22	0.73	1.02	0.90	0.99	0.46	0.71	0.36	0.81	0.27	0.79	0.33	0.83	0.22	0.90	0.50	0.62	
23	0.41	0.94	0.41	0.90	0.60	0.64	0.32	0.82	0.19	0.67	0.52	0.88	0.28	0.88	0.39	0.66	
24																	
25																	
26	0.18	0.94	0.28	0.91	0.29	0.61	0.18	0.66	0.23	0.43	0.23	0.91	0.22	0.77	0.23	0.78	
27																	
28	0.40	0.79	0.98	0.75	0.31	0.64	0.33	0.65	0.19	0.30	0.30	0.92	0.21	0.80	0.64	0.79	
29	0.42	0.87	0.22	0.78	0.37	0.57	0.31	0.64	0.41	0.62	0.21	0.93	0.12	0.84	0.36	0.88	
30	0.17	0.83	0.23	0.78	0.24	0.82	0.27	0.71	0.36	0.67	0.18	0.91	0.22	0.74	0.29	0.90	
31																	

## APPENDIX C: TURBIDITY V. CHLORINE RESIDUAL GRAPHS

# APPENDIX C: TURBIDITY V. CHLORINE RESIDUAL GRAPHS

## Harvey Creek Water System Graphs

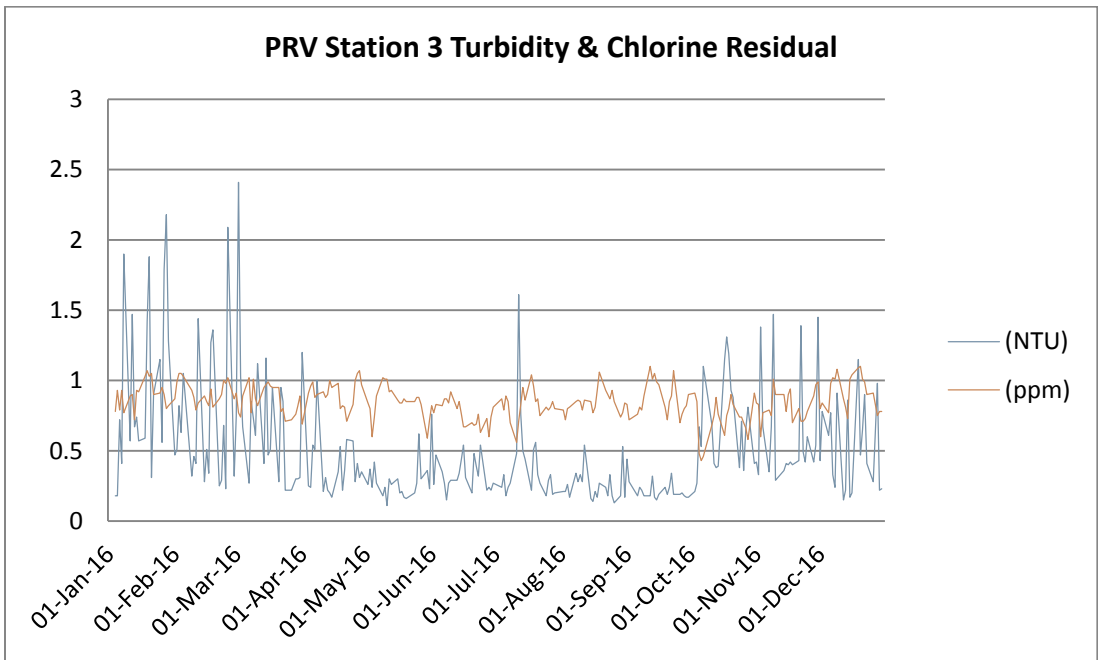
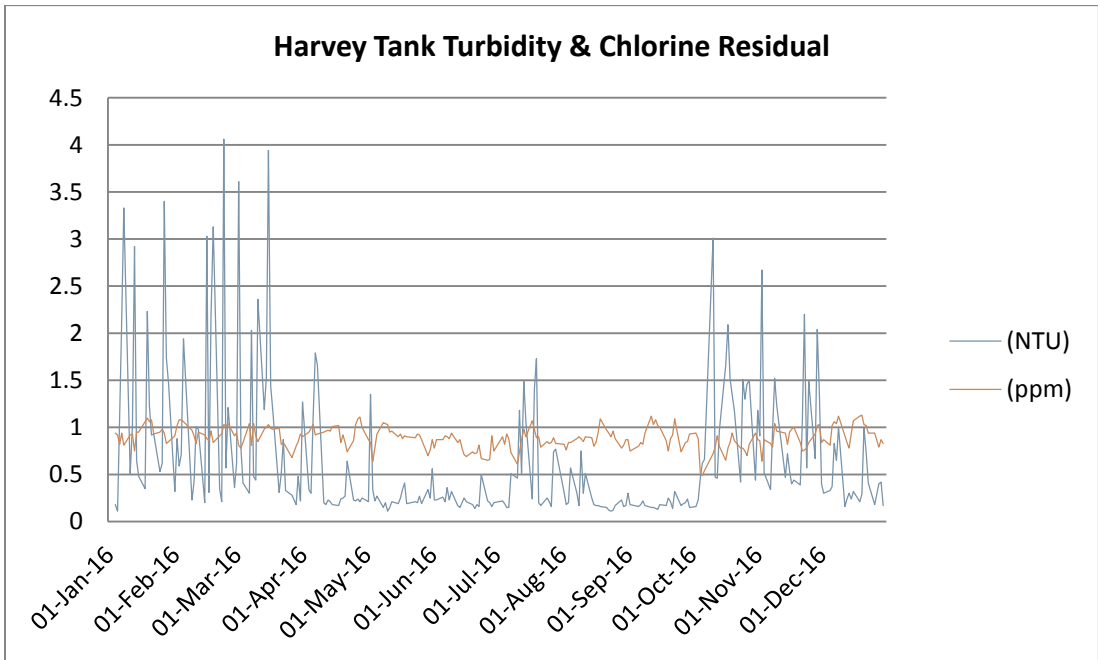

# APPENDIX C: TURBIDITY V. CHLORINE RESIDUAL GRAPHS

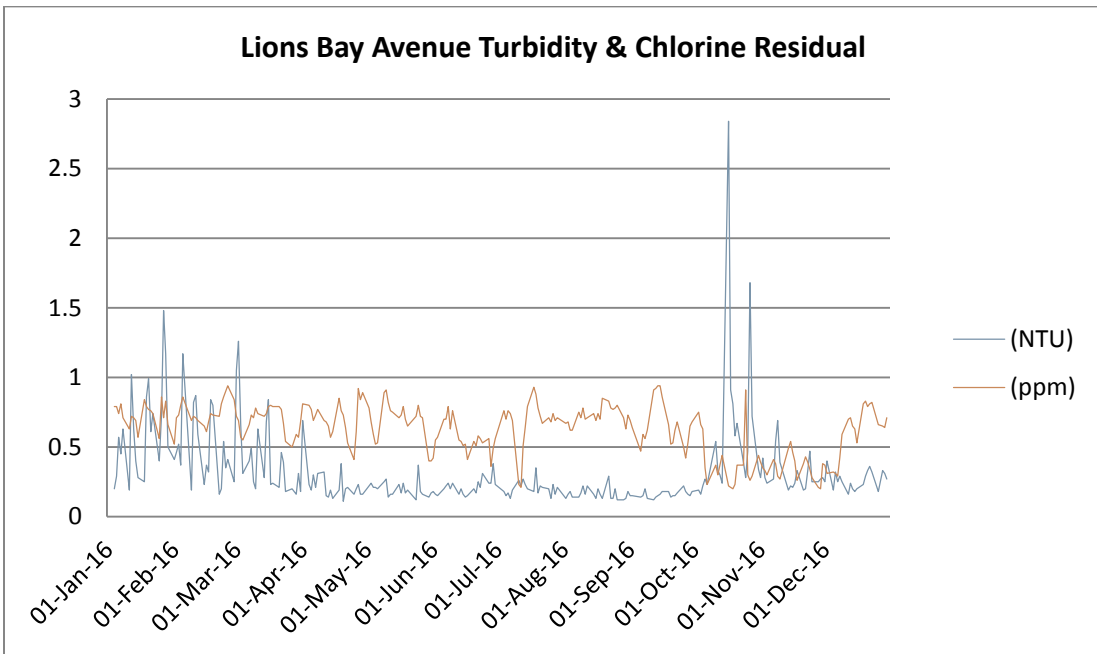
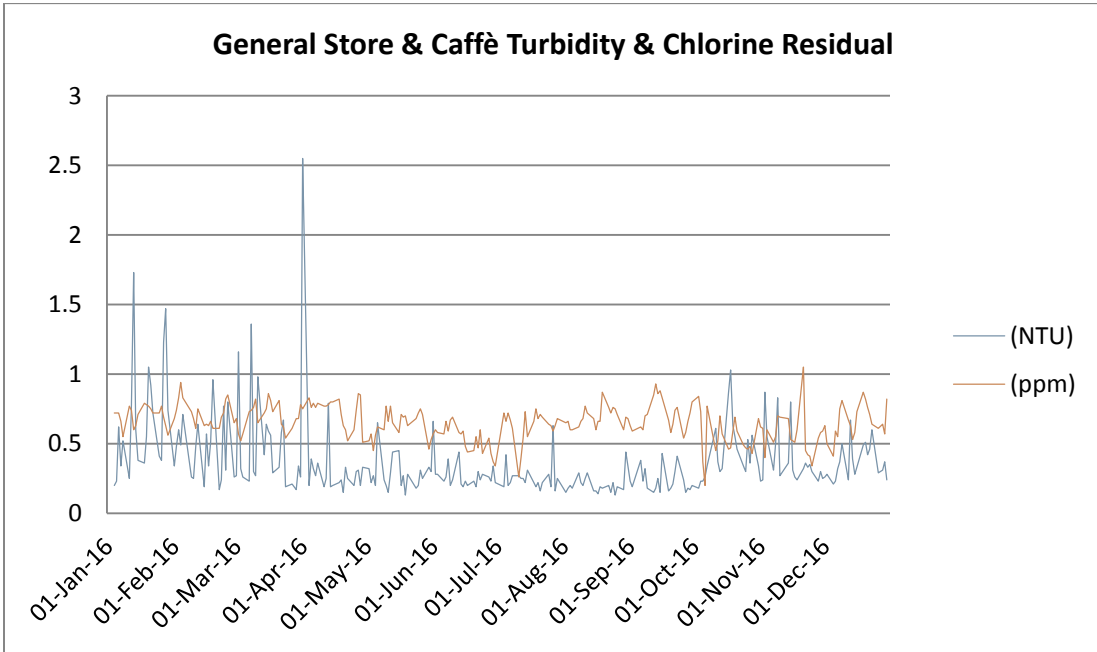

# APPENDIX C: TURBIDITY V. CHLORINE RESIDUAL GRAPHS

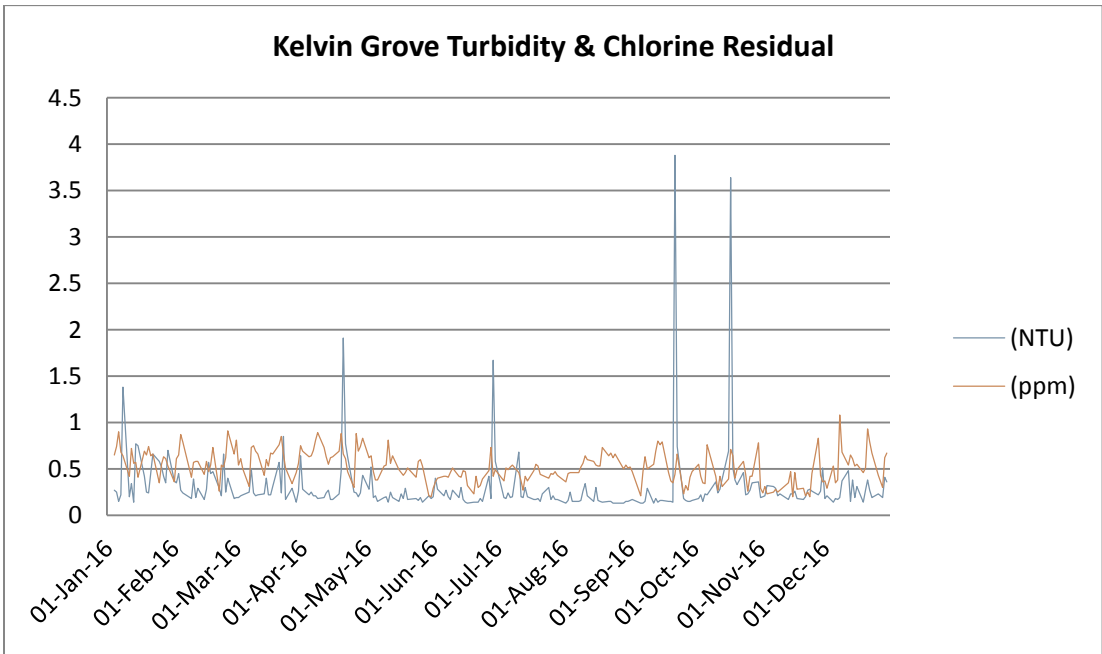

## Magnesia Creek Water System Graphs

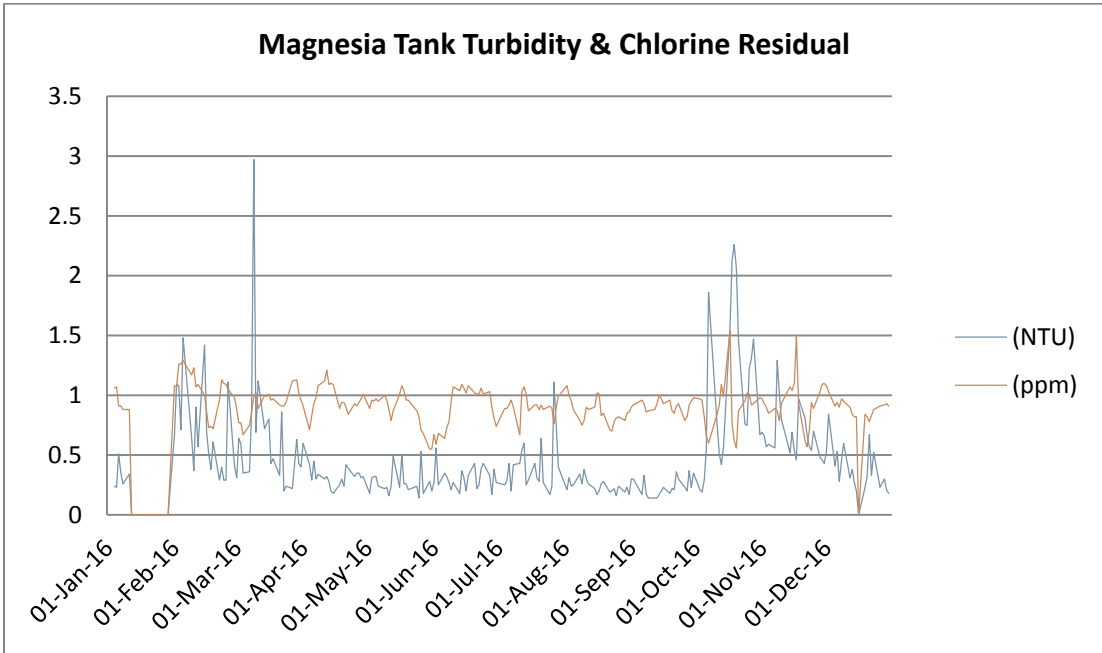

Note: Zero readings in the middle of January and late December of 2016 are indicative of plant shut-downs due to intake blockages.

# APPENDIX C: TURBIDITY V. CHLORINE RESIDUAL GRAPHS

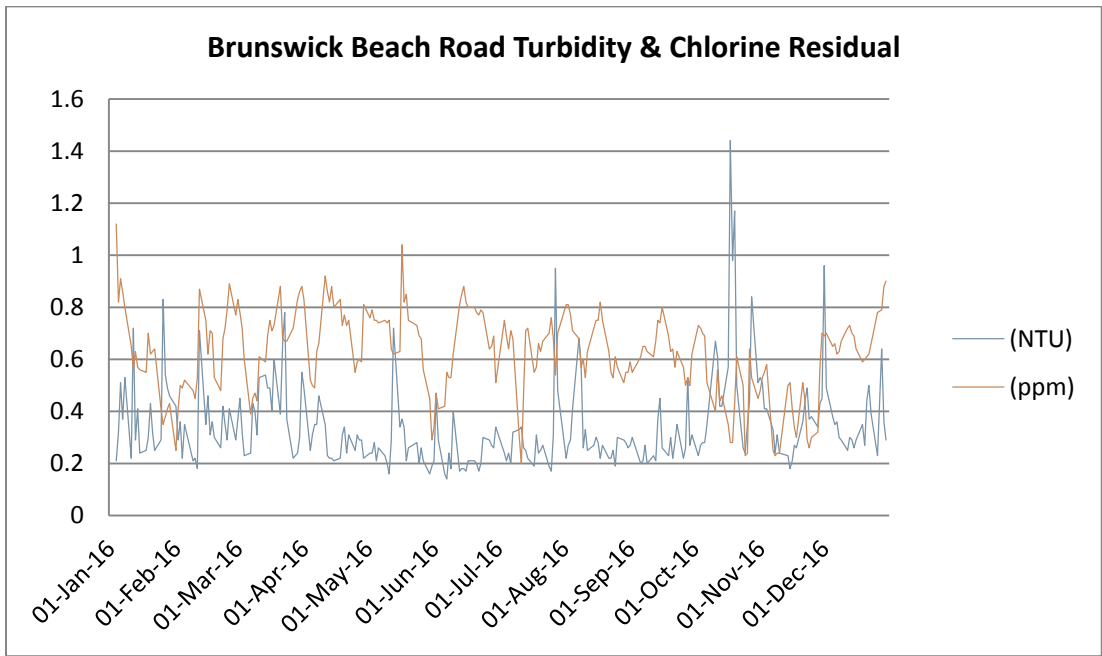
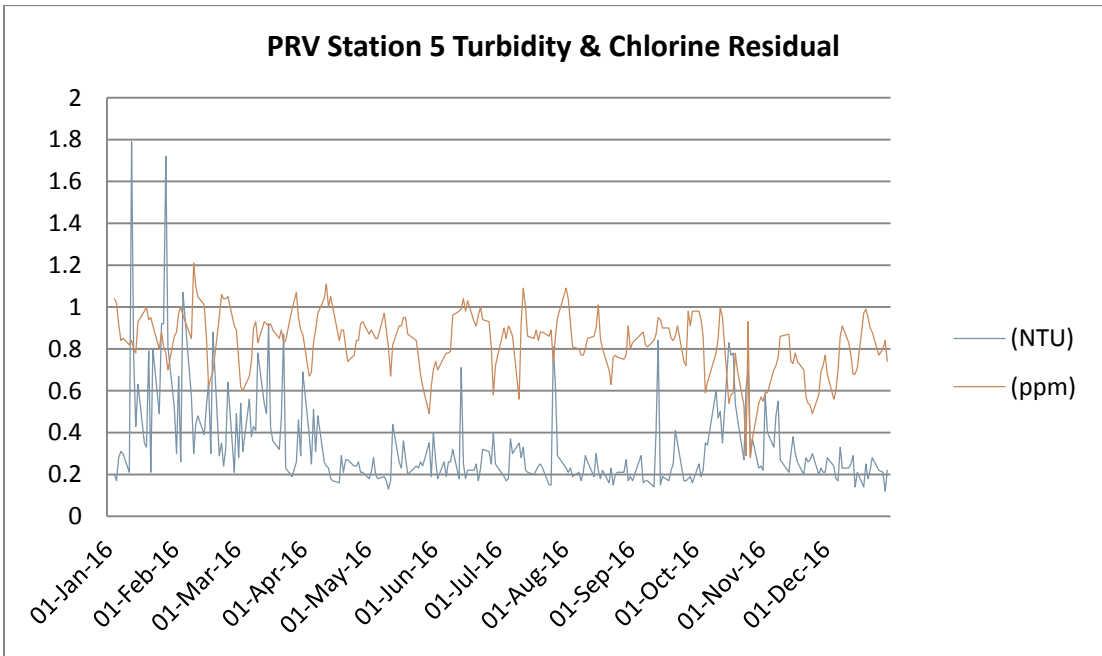

## APPENDIX D: METALS & WATER CHEMISTRY TEST RESULTS



VILLAGE OF LIONS BAY  
ATTN: Nikii Hoglund  
PO Box 141, 400 Center Road  
Lions Bay BC V0N 2E0

Date Received: 05-APR-16  
Report Date: 18-APR-16 14:43 (MT)  
Version: FINAL

Client Phone: 604-921-9833

## Certificate of Analysis

Lab Work Order #: L1752219  
Project P.O. #: NOT SUBMITTED  
Job Reference:  
C of C Numbers:  
Legal Site Desc:

Courtney Duncan  
Account Manager

[This report shall not be reproduced except in full without the written authority of the Laboratory.]

ADDRESS: 8081 Lougheed Hwy, Suite 100, Burnaby, BC V5A 1W9 Canada | Phone: +1 604 253 4188 | Fax: +1 604 253 6700  
ALS CANADA LTD Part of the ALS Group A Campbell Brothers Limited Company

**ALS ENVIRONMENTAL ANALYTICAL REPORT**Version: **FINAL**

Sample ID Description Sampled Date Sampled Time Client ID	L1752219-1 Water 05-APR-16 10:30 HARVEY TANK (FIRST DRAW)	L1752219-2 Water 05-APR-16 10:30 HARVEY TANK (AFTER FLUSH)	L1752219-3 Water 05-APR-16 08:05 STORE/CAFE (FIRST DRAW)	L1752219-4 Water 05-APR-16 08:05 STORE/CAFE (AFTER FLUSH)	L1752219-5 Water 05-APR-16 12:50 LIONS BAY AVE. (FIRST DRAW)
<b>Grouping</b>	<b>Analyte</b>				
<b>WATER</b>					
<b>Physical Tests</b>	Hardness (as CaCO3) (mg/L)				
	3.75	3.71	3.80	4.24	4.50
	pH (pH)				
	6.83		6.82		6.90
	Total Suspended Solids (mg/L)				
	<3.0		<3.0		<3.0
	Turbidity (NTU)				
	0.17		0.27		0.15
<b>Anions and Nutrients</b>	Alkalinity, Total (as CaCO3) (mg/L)				
	4.0		3.7		4.1
<b>Organic / Inorganic Carbon</b>	Total Organic Carbon (mg/L)				
	1.04		0.87		0.89
<b>Total Metals</b>	Aluminum (Al)-Total (mg/L)				
	0.085	0.055	0.050	0.033	0.015
	Antimony (Sb)-Total (mg/L)				
	<0.00050	<0.00050	<0.00050	<0.00050	<0.00050
	Arsenic (As)-Total (mg/L)				
	<0.00010	<0.00010	<0.00010	<0.00010	<0.00010
	Barium (Ba)-Total (mg/L)				
	<0.020	<0.020	<0.020	<0.020	<0.020
	Boron (B)-Total (mg/L)				
	<0.10	<0.10	<0.10	<0.10	<0.10
	Cadmium (Cd)-Total (mg/L)				
	<0.00020	<0.00020	<0.00020	<0.00020	<0.00020
	Calcium (Ca)-Total (mg/L)				
	1.26	1.25	1.30	1.43	1.55
	Chromium (Cr)-Total (mg/L)				
	<0.0020	<0.0020	<0.0020	<0.0020	<0.0020
	Copper (Cu)-Total (mg/L)				
	0.0123	0.0041	0.0178	0.185	0.728
	Iron (Fe)-Total (mg/L)				
	0.031	<0.030	0.084	0.062	<0.030
	Lead (Pb)-Total (mg/L)				
	<0.00050	<0.00050	<0.00050	0.00898	0.00075
	Magnesium (Mg)-Total (mg/L)				
	0.15	0.14	0.13	0.16	0.15
	Manganese (Mn)-Total (mg/L)				
	<0.0020	<0.0020	<0.0020	<0.0020	<0.0020
	Mercury (Hg)-Total (mg/L)				
	<0.00020	<0.00020	<0.00020	<0.00020	<0.00020
	Potassium (K)-Total (mg/L)				
	<0.10	<0.10	<0.10	<0.10	<0.10
	Selenium (Se)-Total (mg/L)				
	<0.0010	<0.0010	<0.0010	<0.0010	<0.0010
	Sodium (Na)-Total (mg/L)				
	2.2	2.2	2.1	2.2	2.1
	Uranium (U)-Total (mg/L)				
	<0.00010	<0.00010	<0.00010	<0.00010	<0.00010
	Zinc (Zn)-Total (mg/L)				
	<0.050	<0.050	<0.050	0.139	<0.050
<b>Aggregate Organics</b>	BOD (mg/L)				
	<2.0		<2.0		<2.0
<b>Trihalomethanes</b>	Bromodichloromethane (mg/L)				
	<0.0010		<0.0010		<0.0010
	Bromoform (mg/L)				
	<0.0010		<0.0010		<0.0010
	Dibromochloromethane (mg/L)				
	<0.0010		<0.0010		<0.0010
	Chloroform (mg/L)				
	0.0418		0.0475		0.0506
	Total THMs (mg/L)				
	0.0418		0.0475		0.0506

## ALS ENVIRONMENTAL ANALYTICAL REPORT

18-APR-16 14:43 (MT)

Version: FINAL

Sample ID	Description	Sampled Date	Sampled Time	Client ID	L1752219-6	L1752219-7	L1752219-8	L1752219-9	L1752219-10
					Water	Water	Water	Water	Water
		05-APR-16	12:50	LIONS BAY AVE. (AFTER FLUSH)	05-APR-16	05-APR-16	05-APR-16	05-APR-16	05-APR-16
						08:30	08:30	07:25	07:25
						KELVIN GROVE (FIRST DRAW)	KELVIN GROVE (AFTER FLUSH)	COMMUNITY CENTRE (FIRST DRAW)	COMMUNITY CENTRE (AFTER FLUSH)
Grouping	Analyte								
<b>WATER</b>									
<b>Physical Tests</b>	Hardness (as CaCO3) (mg/L)		4.35	7.06	5.81	5.33	4.05		
	pH (pH)			7.23		6.85			
	Total Suspended Solids (mg/L)			<3.0		<3.0			
	Turbidity (NTU)			0.26		0.21			
<b>Anions and Nutrients</b>	Alkalinity, Total (as CaCO3) (mg/L)			5.2		3.8			
<b>Organic / Inorganic Carbon</b>	Total Organic Carbon (mg/L)			1.03		0.90			
<b>Total Metals</b>	Aluminum (Al)-Total (mg/L)		0.050	0.015	0.058	0.044	0.051		
	Antimony (Sb)-Total (mg/L)		<0.00050	<0.00050	<0.00050	<0.00050	<0.00050	<0.00050	<0.00050
	Arsenic (As)-Total (mg/L)		<0.00010	<0.00010	<0.00010	<0.00010	<0.00010	<0.00010	<0.00010
	Barium (Ba)-Total (mg/L)		<0.020	<0.020	<0.020	<0.020	<0.020	<0.020	<0.020
	Boron (B)-Total (mg/L)		<0.10	<0.10	<0.10	<0.10	<0.10	<0.10	<0.10
	Cadmium (Cd)-Total (mg/L)		<0.00020	<0.00020	<0.00020	<0.00020	<0.00020	<0.00020	<0.00020
	Calcium (Ca)-Total (mg/L)		1.49	2.40	2.11	1.43	1.40		
	Chromium (Cr)-Total (mg/L)		<0.0020	<0.0020	<0.0020	<0.0020	<0.0020	<0.0020	<0.0020
	Copper (Cu)-Total (mg/L)		0.0064	0.201	0.0028	0.0941	0.0286		
	Iron (Fe)-Total (mg/L)		<0.030	0.045	0.052	0.040	0.079		
	Lead (Pb)-Total (mg/L)		<0.00050	0.0455	0.00074	0.00308	0.00070		
	Magnesium (Mg)-Total (mg/L)		0.15	0.26	0.13	0.43	0.14		
	Manganese (Mn)-Total (mg/L)		<0.0020	<0.0020	<0.0020	<0.0020	<0.0020	<0.0020	<0.0020
	Mercury (Hg)-Total (mg/L)		<0.00020	<0.00020	<0.00020	<0.00020	<0.00020	<0.00020	<0.00020
	Potassium (K)-Total (mg/L)		<0.10	<0.10	<0.10	<0.10	<0.10	<0.10	<0.10
	Selenium (Se)-Total (mg/L)		<0.0010	<0.0010	<0.0010	<0.0010	<0.0010	<0.0010	<0.0010
	Sodium (Na)-Total (mg/L)		2.2	2.2	2.2	2.2	2.2		
	Uranium (U)-Total (mg/L)		<0.00010	<0.00010	<0.00010	<0.00010	<0.00010	<0.00010	<0.00010
	Zinc (Zn)-Total (mg/L)		<0.050	0.111	<0.050	0.143	<0.050		
<b>Aggregate Organics</b>	BOD (mg/L)			<2.0		<2.0			
<b>Trihalomethanes</b>	Bromodichloromethane (mg/L)			<0.0010		<0.0010			
	Bromoform (mg/L)			<0.0010		<0.0010			
	Dibromochloromethane (mg/L)			<0.0010		<0.0010			
	Chloroform (mg/L)			0.0604		0.0482			
	Total THMs (mg/L)			0.0604		0.0482			

**ALS ENVIRONMENTAL ANALYTICAL REPORT**Version: **FINAL**

Sample ID Description Sampled Date Sampled Time Client ID	L1752219-11 Water 05-APR-16 09:35 MAGNESIA TANK (FIRST DRAW)	L1752219-12 Water 05-APR-16 09:35 MAGNESIA TANK (AFTER FLUSH)	L1752219-13 Water 05-APR-16 11:55 BRUNSWICK BEACH (FIRST DRAW)	L1752219-14 Water 05-APR-16 11:55 BRUNSWICK BEACH (AFTER FLUSH)	L1752219-15 Water 05-APR-16 07:45 ELEMENTARY SCHOOL (FIRST DRAW)
<b>Grouping</b>	<b>Analyte</b>				
<b>WATER</b>					
<b>Physical Tests</b>					
Hardness (as CaCO3) (mg/L)	9.10	7.93	10.1	9.33	9.86
pH (pH)	6.94		7.11		7.21
Total Suspended Solids (mg/L)	<3.0		<3.0		<3.0
Turbidity (NTU)	0.18		0.22		0.35
<b>Anions and Nutrients</b>					
Alkalinity, Total (as CaCO3) (mg/L)	5.1		5.6		5.7
<b>Organic / Inorganic Carbon</b>					
Total Organic Carbon (mg/L)	0.77		0.67		0.56
<b>Total Metals</b>					
Aluminum (Al)-Total (mg/L)	0.014	0.038	0.017	0.033	0.037
Antimony (Sb)-Total (mg/L)	<0.00050	<0.00050	<0.00050	<0.00050	<0.00050
Arsenic (As)-Total (mg/L)	<0.00010	<0.00010	<0.00010	<0.00010	0.00013
Barium (Ba)-Total (mg/L)	<0.020	<0.020	<0.020	<0.020	<0.020
Boron (B)-Total (mg/L)	<0.10	<0.10	<0.10	<0.10	<0.10
Cadmium (Cd)-Total (mg/L)	<0.00020	<0.00020	<0.00020	<0.00020	<0.00020
Calcium (Ca)-Total (mg/L)	3.07	2.63	3.39	3.14	3.36
Chromium (Cr)-Total (mg/L)	<0.0020	<0.0020	<0.0020	<0.0020	<0.0020
Copper (Cu)-Total (mg/L)	0.571	0.0115	0.274	0.0046	0.0142
Iron (Fe)-Total (mg/L)	0.124	<0.030	0.042	0.038	0.163
Lead (Pb)-Total (mg/L)	0.00295	<0.00050	0.00273	<0.00050	0.00164
Magnesium (Mg)-Total (mg/L)	0.35	0.33	0.40	0.36	0.36
Manganese (Mn)-Total (mg/L)	<0.0020	<0.0020	<0.0020	<0.0020	<0.0020
Mercury (Hg)-Total (mg/L)	<0.00020	<0.00020	<0.00020	<0.00020	<0.00020
Potassium (K)-Total (mg/L)	<0.10	<0.10	<0.10	<0.10	<0.10
Selenium (Se)-Total (mg/L)	<0.0010	<0.0010	<0.0010	<0.0010	<0.0010
Sodium (Na)-Total (mg/L)	2.4	2.6	2.7	2.6	2.6
Uranium (U)-Total (mg/L)	<0.00010	<0.00010	<0.00010	<0.00010	<0.00010
Zinc (Zn)-Total (mg/L)	0.265	<0.050	<0.050	<0.050	<0.050
<b>Aggregate Organics</b>					
BOD (mg/L)	<2.0		<2.0		<2.0
<b>Trihalomethanes</b>					
Bromodichloromethane (mg/L)	<0.0010		<0.0010		<0.0010
Bromoform (mg/L)	<0.0010		<0.0010		<0.0010
Dibromochloromethane (mg/L)	<0.0010		<0.0010		<0.0010
Chloroform (mg/L)	0.0329		0.0374		0.0431
Total THMs (mg/L)	0.0329		0.0374		0.0431

Sample ID	Description	Sampled Date	Sampled Time	Client ID		
L1752219-16	Water	05-APR-16	07:45	ELEMENTARY SCHOOL (AFTER FLUSH)		
L1752219-17	Surface Water	05-APR-16	10:35	HARVEY RAW WATER		
L1752219-18	Surface Water	05-APR-16	09:40	MAGNESIA RAW WATER		
Grouping	Analyte					
<b>WATER</b>						
<b>Physical Tests</b>	Hardness (as CaCO3) (mg/L)	10.0	3.36	7.44		
	pH (pH)		6.65	6.77		
	Total Suspended Solids (mg/L)		<3.0	<3.0		
	Turbidity (NTU)		0.15	0.17		
<b>Anions and Nutrients</b>	Alkalinity, Total (as CaCO3) (mg/L)		2.8	3.2		
	Total Organic Carbon (mg/L)		0.82	0.98		
<b>Total Metals</b>	Aluminum (Al)-Total (mg/L)	0.034	0.050	0.037		
	Antimony (Sb)-Total (mg/L)	<0.00050	<0.00050	<0.00050		
	Arsenic (As)-Total (mg/L)	0.00012	<0.00010	<0.00010		
	Barium (Ba)-Total (mg/L)	<0.020	<0.020	<0.020		
	Boron (B)-Total (mg/L)	<0.10	<0.10	<0.10		
	Cadmium (Cd)-Total (mg/L)	<0.00020	<0.00020	<0.00020		
	Calcium (Ca)-Total (mg/L)	3.41	1.11	2.45		
	Chromium (Cr)-Total (mg/L)	<0.0020	<0.0020	<0.0020		
	Copper (Cu)-Total (mg/L)	0.0132	0.0065	0.0033		
	Iron (Fe)-Total (mg/L)	0.166	<0.030	<0.030		
	Lead (Pb)-Total (mg/L)	0.00962	<0.00050	<0.00050		
	Magnesium (Mg)-Total (mg/L)	0.36	0.14	0.32		
	Manganese (Mn)-Total (mg/L)	<0.0020	<0.0020	<0.0020		
	Mercury (Hg)-Total (mg/L)	<0.00020	<0.00020	<0.00020		
	Potassium (K)-Total (mg/L)	<0.10	<0.10	<0.10		
	Selenium (Se)-Total (mg/L)	<0.0010	<0.0010	<0.0010		
	Sodium (Na)-Total (mg/L)	2.7	<2.0	<2.0		
	Uranium (U)-Total (mg/L)	<0.00010	<0.00010	<0.00010		
	Zinc (Zn)-Total (mg/L)	<0.050	<0.050	<0.050		
	<b>Aggregate Organics</b>	BOD (mg/L)		<2.0	<2.0	
<b>Trihalomethanes</b>		Bromodichloromethane (mg/L)				
	Bromoform (mg/L)					
	Dibromochloromethane (mg/L)					
	Chloroform (mg/L)					
	Total THMs (mg/L)					

## Reference Information

### QC Samples with Qualifiers & Comments:

QC Type Description	Parameter	Qualifier	Applies to Sample Number(s)
Method Blank	Alkalinity, Total (as CaCO <sub>3</sub> )	B	L1752219-1, -11, -13, -15, -17, -18, -3, -5, -7, -9
Matrix Spike	Total Organic Carbon	MS-B	L1752219-17, -18
Matrix Spike	Total Organic Carbon	MS-B	L1752219-17, -18

### Qualifiers for Individual Parameters Listed:

Qualifier	Description
B	Method Blank exceeds ALS DQO. All associated sample results are at least 5 times greater than blank levels and are considered reliable.
MS-B	Matrix Spike recovery could not be accurately calculated due to high analyte background in sample.

### Test Method References:

ALS Test Code	Matrix	Test Description	Method Reference**
<b>ALK-TITR-VA</b>	Water	Alkalinity Species by Titration	APHA 2320 Alkalinity
This analysis is carried out using procedures adapted from APHA Method 2320 "Alkalinity". Total alkalinity is determined by potentiometric titration to a pH 4.5 endpoint. Bicarbonate, carbonate and hydroxide alkalinity are calculated from phenolphthalein alkalinity and total alkalinity values.			
<b>BOD5-VA</b>	Water	Biochemical Oxygen Demand- 5 day	APHA 5210 B- "BIOCHEMICAL OXYGEN DEMAND"
This analysis is carried out using procedures adapted from APHA Method 5210 B - "Biochemical Oxygen Demand (BOD)". All forms of biochemical oxygen demand (BOD) are determined by diluting and incubating a sample for a specified time period, and measuring the oxygen depletion using a dissolved oxygen meter. Dissolved BOD (SOLUBLE) is determined by filtering the sample through a glass fibre filter prior to dilution. Carbonaceous BOD (CBOD) is determined by adding a nitrification inhibitor to the diluted sample prior to incubation.			
<b>BOD5-VA</b>	Water	Biochemical Oxygen Demand- 5 day	APHA 5210 B- BIOCHEMICAL OXYGEN DEMAND
This analysis is carried out using procedures adapted from APHA Method 5210 B - "Biochemical Oxygen Demand (BOD)". All forms of biochemical oxygen demand (BOD) are determined by diluting and incubating a sample for a specified time period, and measuring the oxygen depletion using a dissolved oxygen meter. Dissolved BOD (SOLUBLE) is determined by filtering the sample through a glass fibre filter prior to dilution. Carbonaceous BOD (CBOD) is determined by adding a nitrification inhibitor to the diluted sample prior to incubation.			
<b>CARBONS-TOC-VA</b>	Water	Total organic carbon by combustion	APHA 5310B TOTAL ORGANIC CARBON (TOC)
This analysis is carried out using procedures adapted from APHA Method 5310 "Total Organic Carbon (TOC)".			
<b>HARDNESS-CALC-VA</b>	Water	Hardness	APHA 2340B
Hardness (also known as Total Hardness) is calculated from the sum of Calcium and Magnesium concentrations, expressed in CaCO <sub>3</sub> equivalents. Dissolved Calcium and Magnesium concentrations are preferentially used for the hardness calculation.			
<b>HG-TOT-CVAFS-VA</b>	Water	Total Hg in Water by CVAFS LOR=50ppt	EPA 1631E (mod)
This analysis is carried out using procedures adapted from "Standard Methods for the Examination of Water and Wastewater" published by the American Public Health Association, and with procedures adapted from "Test Methods for Evaluating Solid Waste" SW-846 published by the United States Environmental Protection Agency (EPA). The procedure involves a cold-oxidation of the acidified sample using bromine monochloride prior to reduction of the sample with stannous chloride. Instrumental analysis is by cold vapour atomic fluorescence spectrophotometry or atomic absorption spectrophotometry (EPA Method 245.7).			
<b>MET-T-CCMS-VA</b>	Water	Total Metals in Water by CRC ICPMS	EPA 200.2/6020A (mod)
Water samples are digested with nitric and hydrochloric acids, and analyzed by CRC ICPMS.			
Method Limitation (re: Sulfur): Sulfide and volatile sulfur species may not be recovered by this method.			
<b>MET-TOT-ICP-VA</b>	Water	Total Metals in Water by ICPOES	EPA SW-846 3005A/6010B
This analysis is carried out using procedures adapted from "Standard Methods for the Examination of Water and Wastewater" published by the American Public Health Association, and with procedures adapted from "Test Methods for Evaluating Solid Waste" SW-846 published by the United States Environmental Protection Agency (EPA). The procedures may involve preliminary sample treatment by acid digestion, using either hotblock or microwave oven (EPA Method 3005A). Instrumental analysis is by inductively coupled plasma - optical emission spectrophotometry (EPA Method 6010B).			
<b>PH-PCT-VA</b>	Water	pH by Meter (Automated)	APHA 4500-H "pH Value"
This analysis is carried out using procedures adapted from APHA Method 4500-H "pH Value". The pH is determined in the laboratory using a pH electrode			
It is recommended that this analysis be conducted in the field.			
<b>PH-PCT-VA</b>	Water	pH by Meter (Automated)	APHA 4500-H pH Value
This analysis is carried out using procedures adapted from APHA Method 4500-H "pH Value". The pH is determined in the laboratory using a pH electrode			
It is recommended that this analysis be conducted in the field.			
<b>THM-HSMS-VA</b>	Water	VOC (THM) by Headspace GCMS	EPA SW-846, METHOD 8260

## Reference Information

Version: FINAL

This procedure is suitable for the analysis of trihalomethanes (chloroform, bromodichloromethane, dibromochloromethane, and bromoform) in chlorinated waters that have been treated to prevent the formation of trihalomethanes after sample collection. The analysis involves the headspace extraction of the sample prior to analysis by capillary column gas chromatography with mass spectrometric detection (GC/MS). The trihalomethanes analysis is carried out using procedures adapted from "Test Methods for Evaluating Solid Waste" SW-846, Method 8260, published by the United States Environmental Protection Agency (EPA).

**THM-SUM-CALC-VA**      Water      Total Trihalomethane-THM      CALCULATION

Total Trihalomethanes (where not conducted as part of a formation potential analysis) is equal to the sum of the individual parameter concentrations with non-detect results treated as zero.

**TSS-VA**      Water      Total Suspended Solids by Gravimetric      APHA 2540 D - GRAVIMETRIC

This analysis is carried out using procedures adapted from APHA Method 2540 "Solids". Solids are determined gravimetrically. Total Suspended Solids (TSS) are determined by filtering a sample through a glass fibre filter, TSS is determined by drying the filter at 104 degrees celsius. Samples containing very high dissolved solid content (i.e. seawaters, brackish waters) may produce a positive bias by this method. Alternate analysis methods are available for these types of samples.

**TURBIDITY-VA**      Water      Turbidity by Meter      APHA 2130 "Turbidity"

This analysis is carried out using procedures adapted from APHA Method 2130 "Turbidity". Turbidity is determined by the nephelometric method.

**TURBIDITY-VA**      Water      Turbidity by Meter      APHA 2130 Turbidity

This analysis is carried out using procedures adapted from APHA Method 2130 "Turbidity". Turbidity is determined by the nephelometric method.

---

\*\* ALS test methods may incorporate modifications from specified reference methods to improve performance.

*The last two letters of the above test code(s) indicate the laboratory that performed analytical analysis for that test. Refer to the list below:*

---

Laboratory Definition Code	Laboratory Location
VA	ALS ENVIRONMENTAL - VANCOUVER, BRITISH COLUMBIA, CANADA

---

### Chain of Custody Numbers:

#### GLOSSARY OF REPORT TERMS

*Surrogate - A compound that is similar in behaviour to target analyte(s), but that does not occur naturally in environmental samples. For applicable tests, surrogates are added to samples prior to analysis as a check on recovery.*

*mg/kg - milligrams per kilogram based on dry weight of sample.*

*mg/kg wwt - milligrams per kilogram based on wet weight of sample.*

*mg/kg lwt - milligrams per kilogram based on lipid-adjusted weight of sample.*

*mg/L - milligrams per litre.*

*< - Less than.*

*D.L. - The reported Detection Limit, also known as the Limit of Reporting (LOR).*

*N/A - Result not available. Refer to qualifier code and definition for explanation.*

*Test results reported relate only to the samples as received by the laboratory.*

**UNLESS OTHERWISE STATED, ALL SAMPLES WERE RECEIVED IN ACCEPTABLE CONDITION.**

*Analytical results in unsigned test reports with the DRAFT watermark are subject to change, pending final QC review.*





VILLAGE OF LIONS BAY  
ATTN: Nai Jaffer  
PO Box 141, 400 Center Road  
Lions Bay BC V0N 2E0

Date Received: 27-SEP-16  
Report Date: 12-OCT-16 12:57 (MT)  
Version: FINAL

Client Phone: 604-921-9833

## Certificate of Analysis

Lab Work Order #: L1835131  
Project P.O. #: NOT SUBMITTED  
Job Reference:  
C of C Numbers:  
Legal Site Desc:

Courtney Duncan  
Account Manager

[This report shall not be reproduced except in full without the written authority of the Laboratory.]

ADDRESS: 8081 Lougheed Hwy, Suite 100, Burnaby, BC V5A 1W9 Canada | Phone: +1 604 253 4188 | Fax: +1 604 253 6700  
ALS CANADA LTD Part of the ALS Group A Campbell Brothers Limited Company

## ALS ENVIRONMENTAL ANALYTICAL REPORT

12-OCT-16 12:57 (MT)

Version: FINAL

Sample ID	Description	Sampled Date	Sampled Time	Client ID	L1835131-1	L1835131-2	L1835131-3	L1835131-4	L1835131-5		
					L1835131-1 WATER 27-SEP-16 10:40 HARVEY TANK (FIRST DRAW)	L1835131-2 WATER 27-SEP-16 10:40 HARVEY TANK (AFTER FLUSH)	L1835131-3 WATER 27-SEP-16 07:45 STORE / CAFE (FIRST DRAW)	L1835131-4 WATER 27-SEP-16 07:45 STORE / CAFE (AFTER FLUSH)	L1835131-5 WATER 27-SEP-16 11:25 LIONS BAY AVE. (FIRST DRAW)		
Grouping	Analyte										
<b>WATER</b>											
<b>Physical Tests</b>	Hardness (as CaCO3) (mg/L)	5.63	HTC	5.65	HTC	6.05	HTC	5.73	HTC	6.42	HTC
	pH (pH)	6.54		6.93						6.96	
	Total Suspended Solids (mg/L)	<3.0		<3.0						<3.0	
	Turbidity (NTU)	0.11		0.11						0.10	
<b>Anions and Nutrients</b>	Alkalinity, Total (as CaCO3) (mg/L)	7.2		5.4						5.5	
<b>Organic / Inorganic Carbon</b>	Total Organic Carbon (mg/L)	1.22		1.05						1.09	
<b>Total Metals</b>	Aluminum (Al)-Total (mg/L)	0.032		0.030		0.030		0.030		0.022	
	Antimony (Sb)-Total (mg/L)	<0.00050		<0.00050		<0.00050		<0.00050		<0.00050	
	Arsenic (As)-Total (mg/L)	0.00011		0.00010		<0.00010		0.00011		<0.00010	
	Barium (Ba)-Total (mg/L)	<0.020		<0.020		<0.020		<0.020		<0.020	
	Boron (B)-Total (mg/L)	<0.10		<0.10		<0.10		<0.10		<0.10	
	Cadmium (Cd)-Total (mg/L)	<0.00020		<0.00020		<0.00020		<0.00020		<0.00020	
	Calcium (Ca)-Total (mg/L)	1.92		1.92		2.05		1.97		2.23	
	Chromium (Cr)-Total (mg/L)	<0.0020		<0.0020		<0.0020		<0.0020		<0.0020	
	Copper (Cu)-Total (mg/L)	0.0086		0.0040		0.0751		0.0073		0.241	
	Iron (Fe)-Total (mg/L)	<0.030		<0.030		0.051		0.042		<0.030	
	Lead (Pb)-Total (mg/L)	<0.00050		<0.00050		0.00650		<0.00050		0.00181	
	Magnesium (Mg)-Total (mg/L)	0.20		0.21		0.23		0.20		0.21	
	Manganese (Mn)-Total (mg/L)	<0.0020		<0.0020		<0.0020		<0.0020		<0.0020	
	Mercury (Hg)-Total (mg/L)	<0.00020		<0.00020		<0.00020		<0.00020		<0.00020	
	Potassium (K)-Total (mg/L)	0.12		0.12		0.13		0.13		0.13	
	Selenium (Se)-Total (mg/L)	<0.0010		<0.0010		<0.0010		<0.0010		<0.0010	
	Sodium (Na)-Total (mg/L)	2.3		2.3		2.3		2.3		2.3	
	Uranium (U)-Total (mg/L)	<0.00010		<0.00010		<0.00010		<0.00010		<0.00010	
	Zinc (Zn)-Total (mg/L)	<0.050		<0.050		0.055		<0.050		<0.050	
<b>Aggregate Organics</b>	BOD (mg/L)	<2.0		<2.0						<2.0	
<b>Trihalomethanes</b>	Bromodichloromethane (mg/L)	<0.0010		<0.0010		<0.0010		<0.0010		<0.0010	
	Bromoform (mg/L)	<0.0010		<0.0010		<0.0010		<0.0010		<0.0010	
	Dibromochloromethane (mg/L)	<0.0010		<0.0010		<0.0010		<0.0010		<0.0010	
	Chloroform (mg/L)	0.0409		0.0499		0.0499		0.0567		0.0567	
	Total THMs (mg/L)	0.0409		0.0499		0.0499		0.0567		0.0567	

## ALS ENVIRONMENTAL ANALYTICAL REPORT

12-OCT-16 12:57 (MT)

Version: FINAL

Sample ID Description Sampled Date Sampled Time Client ID	L1835131-6 WATER 27-SEP-16 11:25 LIONS BAY AVE. (AFTER FLUSH)	L1835131-7 WATER 27-SEP-16 08:20 KELVIN GROVE (FIRST DRAW)	L1835131-8 WATER 27-SEP-16 08:20 KELVIN GROVE (AFTER FLUSH)	L1835131-9 WATER 27-SEP-16 07:20 COMMUNITY CENTRE (FIRST DRAW)	L1835131-10 WATER 27-SEP-16 07:20 COMMUNITY CENTRE (AFTER FLUSH)	
Grouping	Analyte					
<b>WATER</b>						
<b>Physical Tests</b>	Hardness (as CaCO <sub>3</sub> ) (mg/L)	6.00 <sup>HTC</sup>	7.61 <sup>HTC</sup>	7.55 <sup>HTC</sup>	6.70 <sup>HTC</sup>	6.09 <sup>HTC</sup>
	pH (pH)		7.11		6.97	
	Total Suspended Solids (mg/L)		<3.0		<3.0	
	Turbidity (NTU)		0.11		0.11	
<b>Anions and Nutrients</b>	Alkalinity, Total (as CaCO <sub>3</sub> ) (mg/L)		7.0		5.6	
<b>Organic / Inorganic Carbon</b>	Total Organic Carbon (mg/L)		1.13		0.95	
<b>Total Metals</b>	Aluminum (Al)-Total (mg/L)	0.033	0.026	0.048	0.024	0.033
	Antimony (Sb)-Total (mg/L)	<0.00050	<0.00050	<0.00050	<0.00050	<0.00050
	Arsenic (As)-Total (mg/L)	<0.00010	<0.00010	0.00012	<0.00010	0.00011
	Barium (Ba)-Total (mg/L)	<0.020	<0.020	<0.020	<0.020	<0.020
	Boron (B)-Total (mg/L)	<0.10	<0.10	<0.10	<0.10	<0.10
	Cadmium (Cd)-Total (mg/L)	<0.00020	<0.00020	<0.00020	<0.00020	<0.00020
	Calcium (Ca)-Total (mg/L)	2.06	2.69	2.73	2.16	2.11
	Chromium (Cr)-Total (mg/L)	<0.0020	<0.0020	<0.0020	<0.0020	<0.0020
	Copper (Cu)-Total (mg/L)	0.0030	0.175	0.0021	0.0924	0.0316
	Iron (Fe)-Total (mg/L)	<0.030	0.085	0.053	<0.030	0.040
	Lead (Pb)-Total (mg/L)	<0.00050	0.0437	0.00060	0.00268	0.00067
	Magnesium (Mg)-Total (mg/L)	0.21	0.22	0.18	0.32	0.20
	Manganese (Mn)-Total (mg/L)	<0.0020	<0.0020	<0.0020	<0.0020	<0.0020
	Mercury (Hg)-Total (mg/L)	<0.00020	<0.00020	<0.00020	<0.00020	<0.00020
	Potassium (K)-Total (mg/L)	0.13	0.13	0.13	0.13	0.13
	Selenium (Se)-Total (mg/L)	<0.0010	<0.0010	<0.0010	<0.0010	<0.0010
	Sodium (Na)-Total (mg/L)	2.3	2.4	2.4	2.4	2.4
	Uranium (U)-Total (mg/L)	<0.00010	<0.00010	<0.00010	<0.00010	<0.00010
	Zinc (Zn)-Total (mg/L)	<0.050	<0.050	<0.050	0.101	<0.050
<b>Aggregate Organics</b>	BOD (mg/L)		<2.0		<2.0	
<b>Trihalomethanes</b>	Bromodichloromethane (mg/L)		<0.0010		<0.0010	
	Bromoform (mg/L)		<0.0010		<0.0010	
	Dibromochloromethane (mg/L)		<0.0010		<0.0010	
	Chloroform (mg/L)		0.0799		0.0506	
	Total THMs (mg/L)		0.0799		0.0506	

## ALS ENVIRONMENTAL ANALYTICAL REPORT

12-OCT-16 12:57 (MT)

Version: FINAL

Sample ID	Description	Sampled Date	Sampled Time	Client ID	L1835131-11	L1835131-12	L1835131-13	L1835131-14	L1835131-15
					WATER	WATER	WATER	WATER	SURFACE WATER
		27-SEP-16	09:15		27-SEP-16	27-SEP-16	27-SEP-16	27-SEP-16	27-SEP-16
					09:15	09:15	09:50	09:50	10:45
					MAGNESIA TANK (FIRST DRAW)	MAGNESIA TANK (AFTER FLUSH)	BRUNSWICK BEACH (FIRST DRAW)	BRUNSWICK BEACH (AFTER FLUSH)	HARVEY RAW WATER (AFTER FLUSH)
Grouping	Analyte								
<b>WATER</b>									
<b>Physical Tests</b>	Hardness (as CaCO3) (mg/L)				13.0 <sup>HTC</sup>	13.3 <sup>HTC</sup>	14.9 <sup>HTC</sup>	13.8 <sup>HTC</sup>	5.72 <sup>HTC</sup>
	pH (pH)				6.89		6.99		6.94
	Total Suspended Solids (mg/L)				<3.0		<3.0		<3.0
	Turbidity (NTU)				0.11		0.21		0.25
<b>Anions and Nutrients</b>	Alkalinity, Total (as CaCO3) (mg/L)				4.9		5.8		5.4
	Total Organic Carbon (mg/L)				0.95		0.72		1.06
<b>Total Metals</b>	Aluminum (Al)-Total (mg/L)				0.022	0.024	0.012	0.024	0.029
	Antimony (Sb)-Total (mg/L)				<0.00050	<0.00050	<0.00050	<0.00050	<0.00050
	Arsenic (As)-Total (mg/L)				0.00011	0.00011	<0.00010	0.00012	0.00010
	Barium (Ba)-Total (mg/L)				<0.020	<0.020	<0.020	<0.020	<0.020
	Boron (B)-Total (mg/L)				<0.10	<0.10	<0.10	<0.10	<0.10
	Cadmium (Cd)-Total (mg/L)				<0.00020	<0.00020	<0.00020	<0.00020	<0.00020
	Calcium (Ca)-Total (mg/L)				4.45	4.53	5.23	4.78	1.93
	Chromium (Cr)-Total (mg/L)				<0.0020	<0.0020	<0.0020	<0.0020	<0.0020
	Copper (Cu)-Total (mg/L)				0.0224	0.0109	0.214	0.0045	0.0076
	Iron (Fe)-Total (mg/L)				<0.030	<0.030	0.037	0.039	<0.030
	Lead (Pb)-Total (mg/L)				<0.00050	<0.00050	0.00296	<0.00050	<0.00050
	Magnesium (Mg)-Total (mg/L)				0.47	0.47	0.46	0.45	0.22
	Manganese (Mn)-Total (mg/L)				<0.0020	<0.0020	<0.0020	<0.0020	<0.0020
	Mercury (Hg)-Total (mg/L)				<0.00020	<0.00020	<0.00020	<0.00020	<0.00020
	Potassium (K)-Total (mg/L)				<0.10	<0.10	0.10	0.10	0.12
	Selenium (Se)-Total (mg/L)				<0.0010	<0.0010	<0.0010	<0.0010	<0.0010
	Sodium (Na)-Total (mg/L)				3.1	3.2	3.1	3.0	<2.0
	Uranium (U)-Total (mg/L)				<0.00010	<0.00010	<0.00010	<0.00010	<0.00010
	Zinc (Zn)-Total (mg/L)				<0.050	<0.050	<0.050	<0.050	<0.050
	<b>Aggregate Organics</b>	BOD (mg/L)				<2.0		<2.0	
<b>Trihalomethanes</b>	Bromodichloromethane (mg/L)				<0.0010		<0.0010		
	Bromoform (mg/L)				<0.0010		<0.0010		
	Dibromochloromethane (mg/L)				<0.0010		<0.0010		
	Chloroform (mg/L)				0.0312		0.0446		
	Total THMs (mg/L)				0.0312		0.0446		

\* Please refer to the Reference Information section for an explanation of any qualifiers detected.

# ALS ENVIRONMENTAL ANALYTICAL REPORT

	<b>Sample ID</b> <b>Description</b> <b>Sampled Date</b> <b>Sampled Time</b> <b>Client ID</b>				
	L1835131-16 SURFACE WATE 27-SEP-16 09:20 MAGNESIA RAW WATER (AFTER FLUSH)				
Grouping	Analyte				
<b>WATER</b>					
<b>Physical Tests</b>	Hardness (as CaCO3) (mg/L)	14.1 <sup>HTC</sup>			
	pH (pH)	6.90			
	Total Suspended Solids (mg/L)	<3.0			
	Turbidity (NTU)	0.11			
<b>Anions and Nutrients</b>	Alkalinity, Total (as CaCO3) (mg/L)	4.5			
<b>Organic / Inorganic Carbon</b>	Total Organic Carbon (mg/L)	0.70			
<b>Total Metals</b>	Aluminum (Al)-Total (mg/L)	0.019			
	Antimony (Sb)-Total (mg/L)	<0.00050			
	Arsenic (As)-Total (mg/L)	0.00010			
	Barium (Ba)-Total (mg/L)	<0.020			
	Boron (B)-Total (mg/L)	<0.10			
	Cadmium (Cd)-Total (mg/L)	<0.00020			
	Calcium (Ca)-Total (mg/L)	4.85			
	Chromium (Cr)-Total (mg/L)	<0.0020			
	Copper (Cu)-Total (mg/L)	0.0061			
	Iron (Fe)-Total (mg/L)	<0.030			
	Lead (Pb)-Total (mg/L)	<0.00050			
	Magnesium (Mg)-Total (mg/L)	0.49			
	Manganese (Mn)-Total (mg/L)	<0.0020			
	Mercury (Hg)-Total (mg/L)	<0.00020			
	Potassium (K)-Total (mg/L)	<0.10			
	Selenium (Se)-Total (mg/L)	<0.0010			
	Sodium (Na)-Total (mg/L)	<2.0			
	Uranium (U)-Total (mg/L)	<0.00010			
	Zinc (Zn)-Total (mg/L)	<0.050			
<b>Aggregate Organics</b>	BOD (mg/L)	<2.0			
<b>Trihalomethanes</b>	Bromodichloromethane (mg/L)				
	Bromoform (mg/L)				
	Dibromochloromethane (mg/L)				
	Chloroform (mg/L)				
	Total THMs (mg/L)				

\* Please refer to the Reference Information section for an explanation of any qualifiers detected.

## Reference Information

Version: FINAL

## Qualifiers for Individual Samples Listed:

Sample Number	Client Sample ID	Qualifier	Description
L1835131-10	COMMUNITY CENTRE (AFT	WSMT	Water sample(s) for total mercury analysis was not submitted in glass or PTFE container with HCl preservative. Results may be biased low.
L1835131-12	MAGNESIA TANK (AFTER F	WSMT	Water sample(s) for total mercury analysis was not submitted in glass or PTFE container with HCl preservative. Results may be biased low.
L1835131-14	BRUNSWICK BEACH (AFTE	WSMT	Water sample(s) for total mercury analysis was not submitted in glass or PTFE container with HCl preservative. Results may be biased low.
L1835131-2	HARVEY TANK (AFTER FLU	WSMT	Water sample(s) for total mercury analysis was not submitted in glass or PTFE container with HCl preservative. Results may be biased low.
L1835131-4	STORE / CAFE (AFTER FLU	WSMT	Water sample(s) for total mercury analysis was not submitted in glass or PTFE container with HCl preservative. Results may be biased low.
L1835131-6	LIONS BAY AVE. (AFTER FL	WSMT	Water sample(s) for total mercury analysis was not submitted in glass or PTFE container with HCl preservative. Results may be biased low.
L1835131-8	KELVIN GROVE (AFTER FLI	WSMT	Water sample(s) for total mercury analysis was not submitted in glass or PTFE container with HCl preservative. Results may be biased low.

## QC Samples with Qualifiers &amp; Comments:

QC Type Description	Parameter	Qualifier	Applies to Sample Number(s)
Matrix Spike	Arsenic (As)-Total	MS-B	L1835131-1, -10, -11, -12, -13, -14, -15, -16, -2, -3, -4, -5, -6, -7, -8, -9
Matrix Spike	Barium (Ba)-Total	MS-B	L1835131-1, -10, -11, -12, -13, -14, -15, -16, -2, -3, -4, -5, -6, -7, -8, -9
Matrix Spike	Calcium (Ca)-Total	MS-B	L1835131-1, -10, -11, -12, -13, -14, -15, -16, -2, -3, -4, -5, -6, -7, -8, -9
Matrix Spike	Iron (Fe)-Total	MS-B	L1835131-1, -10, -11, -12, -13, -14, -15, -16, -2, -3, -4, -5, -6, -7, -8, -9
Matrix Spike	Magnesium (Mg)-Total	MS-B	L1835131-1, -10, -11, -12, -13, -14, -15, -16, -2, -3, -4, -5, -6, -7, -8, -9
Matrix Spike	Manganese (Mn)-Total	MS-B	L1835131-1, -10, -11, -12, -13, -14, -15, -16, -2, -3, -4, -5, -6, -7, -8, -9
Matrix Spike	Sodium (Na)-Total	MS-B	L1835131-1, -10, -11, -12, -13, -14, -15, -16, -2, -3, -4, -5, -6, -7, -8, -9

## Qualifiers for Individual Parameters Listed:

Qualifier	Description
HTC	Hardness was calculated from Total Ca and/or Mg concentrations and may be biased high (dissolved Ca/Mg results unavailable).
MS-B	Matrix Spike recovery could not be accurately calculated due to high analyte background in sample.

## Test Method References:

ALS Test Code	Matrix	Test Description	Method Reference**
<b>ALK-TITR-VA</b>	Water	Alkalinity Species by Titration	APHA 2320 Alkalinity
This analysis is carried out using procedures adapted from APHA Method 2320 "Alkalinity". Total alkalinity is determined by potentiometric titration to a pH 4.5 endpoint. Bicarbonate, carbonate and hydroxide alkalinity are calculated from phenolphthalein alkalinity and total alkalinity values.			
<b>BOD5-VA</b>	Water	Biochemical Oxygen Demand- 5 day	APHA 5210 B- "BIOCHEMICAL OXYGEN DEMAND"
This analysis is carried out using procedures adapted from APHA Method 5210 B - "Biochemical Oxygen Demand (BOD)". All forms of biochemical oxygen demand (BOD) are determined by diluting and incubating a sample for a specified time period, and measuring the oxygen depletion using a dissolved oxygen meter. Dissolved BOD (SOLUBLE) is determined by filtering the sample through a glass fibre filter prior to dilution. Carbonaceous BOD (CBOD) is determined by adding a nitrification inhibitor to the diluted sample prior to incubation.			
<b>BOD5-VA</b>	Water	Biochemical Oxygen Demand- 5 day	APHA 5210 B- BIOCHEMICAL OXYGEN DEMAND
This analysis is carried out using procedures adapted from APHA Method 5210 B - "Biochemical Oxygen Demand (BOD)". All forms of biochemical oxygen demand (BOD) are determined by diluting and incubating a sample for a specified time period, and measuring the oxygen depletion using a dissolved oxygen meter. Dissolved BOD (SOLUBLE) is determined by filtering the sample through a glass fibre filter prior to dilution. Carbonaceous BOD (CBOD) is determined by adding a nitrification inhibitor to the diluted sample prior to incubation.			
<b>CARBONS-TOC-VA</b>	Water	Total organic carbon by combustion	APHA 5310B TOTAL ORGANIC CARBON (TOC)
This analysis is carried out using procedures adapted from APHA Method 5310 "Total Organic Carbon (TOC)".			
<b>HARDNESS-CALC-VA</b>	Water	Hardness	APHA 2340B
Hardness (also known as Total Hardness) is calculated from the sum of Calcium and Magnesium concentrations, expressed in CaCO3 equivalents. Dissolved Calcium and Magnesium concentrations are preferentially used for the hardness calculation.			
<b>HG-TOT-CVAFS-VA</b>	Water	Total Hg in Water by CVAFS LOR=50ppt	EPA 1631E (mod)
This analysis is carried out using procedures adapted from "Standard Methods for the Examination of Water and Wastewater" published by the American Public Health Association, and with procedures adapted from "Test Methods for Evaluating Solid Waste" SW-846 published by the United			

## Reference Information

States Environmental Protection Agency (EPA). The procedure involves a cold-oxidation of the acidified sample using bromine monochloride prior to reduction of the sample with stannous chloride. Instrumental analysis is by cold vapour atomic fluorescence spectrophotometry or atomic absorption spectrophotometry (EPA Method 245.7).

**MET-T-CCMS-VA** Water Total Metals in Water by CRC ICPMS EPA 200.2/6020A (mod)

Water samples are digested with nitric and hydrochloric acids, and analyzed by CRC ICPMS.

Method Limitation (re: Sulfur): Sulfide and volatile sulfur species may not be recovered by this method.

**PH-PCT-VA** Water pH by Meter (Automated) APHA 4500-H "pH Value"

This analysis is carried out using procedures adapted from APHA Method 4500-H "pH Value". The pH is determined in the laboratory using a pH electrode

It is recommended that this analysis be conducted in the field.

**PH-PCT-VA** Water pH by Meter (Automated) APHA 4500-H pH Value

This analysis is carried out using procedures adapted from APHA Method 4500-H "pH Value". The pH is determined in the laboratory using a pH electrode

It is recommended that this analysis be conducted in the field.

**THM-HSMS-VA** Water VOC (THM) by Headspace GCMS EPA SW-846, METHOD 8260

This procedure is suitable for the analysis of trihalomethanes (chloroform, bromodichloromethane, dibromochloromethane, and bromoform) in chlorinated waters that have been treated to prevent the formation of trihalomethanes after sample collection. The analysis involves the headspace extraction of the sample prior to analysis by capillary column gas chromatography with mass spectrometric detection (GC/MS). The trihalomethanes analysis is carried out using procedures adapted from "Test Methods for Evaluating Solid Waste" SW-846, Method 8260, published by the United States Environmental Protection Agency (EPA).

**THM-SUM-CALC-VA** Water Total Trihalomethane-THM CALCULATION

Total Trihalomethanes (where not conducted as part of a formation potential analysis) is equal to the sum of the individual parameter concentrations with non-detect results treated as zero.

**TSS-VA** Water Total Suspended Solids by Gravimetric APHA 2540 D - GRAVIMETRIC

This analysis is carried out using procedures adapted from APHA Method 2540 "Solids". Solids are determined gravimetrically. Total Suspended Solids (TSS) are determined by filtering a sample through a glass fibre filter, TSS is determined by drying the filter at 104 degrees celsius. Samples containing very high dissolved solid content (i.e. seawaters, brackish waters) may produce a positive bias by this method. Alternate analysis methods are available for these types of samples.

**TURBIDITY-VA** Water Turbidity by Meter APHA 2130 "Turbidity"

This analysis is carried out using procedures adapted from APHA Method 2130 "Turbidity". Turbidity is determined by the nephelometric method.

**TURBIDITY-VA** Water Turbidity by Meter APHA 2130 Turbidity

This analysis is carried out using procedures adapted from APHA Method 2130 "Turbidity". Turbidity is determined by the nephelometric method.

---

\*\* ALS test methods may incorporate modifications from specified reference methods to improve performance.

*The last two letters of the above test code(s) indicate the laboratory that performed analytical analysis for that test. Refer to the list below:*

---

Laboratory Definition Code	Laboratory Location
VA	ALS ENVIRONMENTAL - VANCOUVER, BRITISH COLUMBIA, CANADA

---

Chain of Custody Numbers:

---

## Reference Information

Version: FINAL

### GLOSSARY OF REPORT TERMS

*Surrogate* - A compound that is similar in behaviour to target analyte(s), but that does not occur naturally in environmental samples. For applicable tests, surrogates are added to samples prior to analysis as a check on recovery.

*mg/kg* - milligrams per kilogram based on dry weight of sample.

*mg/kg wwt* - milligrams per kilogram based on wet weight of sample.

*mg/kg lwt* - milligrams per kilogram based on lipid-adjusted weight of sample.

*mg/L* - milligrams per litre.

*<* - Less than.

*D.L.* - The reported Detection Limit, also known as the Limit of Reporting (LOR).

*N/A* - Result not available. Refer to qualifier code and definition for explanation.

*Test results reported relate only to the samples as received by the laboratory.*

**UNLESS OTHERWISE STATED, ALL SAMPLES WERE RECEIVED IN ACCEPTABLE CONDITION.**

*Analytical results in unsigned test reports with the DRAFT watermark are subject to change, pending final QC review.*



# Short Holding Time

## Rush Processing

Chain of Custody / Analytical Request Form

Canada Toll Free: 1 800 668-0178 Infrastructure Committee Meeting - April 24, 2017 - Page 65 of 92

www.alsglobal.com

COC #

Page 1 of 1

<b>Report To</b>	<b>Report Format / Distribution</b>	<b>Service Requested</b> (Rush for routine analysis subject to availability)
Company: Village of Lions Bay	<input type="checkbox"/> Standard <input type="checkbox"/> Other	<input checked="" type="radio"/> Regular (Standard Turnaround Times - Business Days)
Contact: Nai Jaffer	<input checked="" type="checkbox"/> PDF <input type="checkbox"/> Excel <input type="checkbox"/> Digital <input type="checkbox"/> Fax	<input type="radio"/> Priority (2-4 Business Days) - 50% Surcharge - Contact ALS to Confirm TAT
Address: 400 Centre Rd Lions Bay, BC V0N 2E0	Email 1: aurrutia@lionsbay.ca	<input type="radio"/> Emergency (1-2 Bus. Days) - 100% Surcharge - Contact ALS to Confirm TAT
Phone: 604 921 9833 Fax:	Email 2: works@lionsbay.ca	<input type="radio"/> Same Day or Weekend Emergency - Contact ALS to Confirm TAT
	Email 3:	

<b>Invoice To</b> Same as Report? <input checked="" type="checkbox"/> Yes <input type="checkbox"/> No	<b>Client / Project Information</b>	<b>Analysis Request</b>											
Hardcopy of Invoice with Report? <input type="checkbox"/> Yes <input type="checkbox"/> No	Job #:	Please indicate below Filtered, Preserved or both (F, P, F/P)											
Company:	PO / AFE:	Hardness	pH	TSS	BOD	Turbidity	Alkalinity Total	Total Metals (First Draw)	Total Metals (After Flush)	Mercury	Total Organic Carbon	Trihalomethanes	Number of Containers
Contact:	LSD:												
Address:													
Phone: Fax:	Quote #:												
Lab Work Order # (lab use only)	ALS Contact: Courtney Duncan												

Sample #	Sample Identification (This description will appear on the report)	Date (dd-mmm-yy)	Time (hh:mm)	Sample Type	Hardness	pH	TSS	BOD	Turbidity	Alkalinity Total	Total Metals (First Draw)	Total Metals (After Flush)	Mercury	Total Organic Carbon	Trihalomethanes	Number of Containers
	Harvey Tank	27-09-16	10:40	Water	X	X	X	X	X	X	X	X	X	X	X	8
	Store / Café	27-09-16	7:45	Water	X	X	X	X	X	X	X	X	X	X	X	8
	Lions Bay Ave.	27-09-16	11:25	Water	X	X	X	X	X	X	X	X	X	X	X	8
	Kelvin Grove	27-09-16	8:20	Water	X	X	X	X	X	X	X	X	X	X	X	8
	Community Centre	27-09-16	7:20	Water	X	X	X	X	X	X	X	X	X	X	X	8
	Magnesia Tank	27-09-16	9:15	Water	X	X	X	X	X	X	X	X	X	X	X	8
	Brunswick Beach	27-09-16	9:50	Water	X	X	X	X	X	X	X	X	X	X	X	8
	Harvey Raw Water	27-09-16	10:45	Surface Water	X	X	X	X	X	X		X	X	X		4
	Magnesia Raw Water	27-09-16	9:20	Surface Water	X	X	X	X	X	X		X	X	X		4

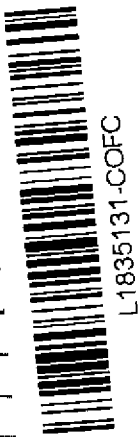

Special Instructions / Regulation: water or land use (CCME-Freshwater Aquatic Life/BC CSR - Commercial/AB Tier 1 - Natural, etc) / Hazardous Details

Failure to complete all portions of this form may delay analysis. Please fill in this form LEGIBLY.

By the use of this form the user acknowledges and agrees with the Terms and Conditions as provided on a separate Excel tab.

Also provided on another Excel tab are the ALS location addresses, phone numbers and sample container / preservation / holding time table for common analyses.

<b>SHIPMENT RELEASE (client use)</b>				<b>SHIPMENT RECEPTION (lab use only)</b>				<b>SHIPMENT VERIFICATION (lab use only)</b>			
Released by:	Date (dd-mmm-yy)	Time (hh-mm)	Received by:	Date:	Time:	Temperature:	Verified by:	Date:	Time:	Observations: Yes / No? If Yes add SIF	
			JC	27/9/16	14:00	7.7 °C					

## APPENDIX E: BOIL WATER ADVISORIES ISSUED

**(NONE ISSUED)**

## APPENDIX F: EMERGENCY RESPONSE PLAN

## APPENDIX F: EMERGENCY RESPONSE PLAN

### EMERGENCY RESPONSE PLAN

Table 1 below outlines the notification process for unusual situations that could potentially affect the Village's potable water system.

**Table 1. Notification of Unusual Situations Potentially Affecting Water Quality**

Situation	Notifying Agency	Agency Notified	Notification Time Frame
E. coli – positive sample	VCH/Lab	VoLB and VCH	Immediate
Total coliform >10/100ml & low chlorine residual	VoLB	VCH	Immediate
Chemical contamination	VoLB	VCH	Immediate
Turbidity events >5 NTU	VoLB	VCH	Immediate
Disinfection failures/continued loss of residual	VoLB	VCH	Immediate for continued loss of residual
Loss of pressure due to high demand	VoLB	VCH	Immediate
Water main breaks	VoLB	VCH	Immediate
Lack of water due to drought or other causes	VoLB	EMBC & VCH	Information only; as drought situation progresses

### E. COLI POSITIVE SAMPLES

1. Any interim samples (samples that have been taken in the period between the time the E. coli sample was first drawn and when the laboratory determined it to be positive) that have been taken from the same sampling station will be immediately examined by the laboratory.
2. The chlorine residual noted on the Water Operator's field sheet will be reviewed by the laboratory and compared to previous test results to determine if there is any localized loss of disinfectant residual.
3. The Public Works Manager (or designate) and VCH will be notified immediately by the laboratory.
4. Arrangements will be made for the immediate collection of a repeat sample, and, where possible, both upstream and downstream of the E. coli positive sample location.
5. VCH and the Public Works Manager (or designate) will liaise and determine the need for a Boil Water Advisory (BWA) to be issued. If it is determined to be warranted, VCH will issue the BWA.
6. The laboratory will continue to test the subsequent samples. Once consecutive negative sample results are returned, the Public Works Manager (or designate) will liaise again with VCH and determine whether the BWA can be lifted.

## APPENDIX F: EMERGENCY RESPONSE PLAN

### CHEMICAL CONTAMINATION

In the event of chemical contamination of the Village's water supply or distribution system, VCH will immediately be notified, and steps will commence to isolate the contaminated area. The level of contamination will be determined through water sampling and testing; identified; and any public health risk factors associated with the chemical presence and level will be determined. A public advisory will be issued and carried out by the Public Works Manager (or designate) under the guidance of VCH. Once the contamination is remedied and consecutive negative sample results are returned from the laboratory, the Public Works Manager (or designate) will again liaise with VCH and determine whether the public advisory can be lifted.

### TURBIDITY EVENTS

Turbidity in the Village's treated water system is monitored on a regular basis through the water sampling and testing program. Water sample turbidity results that register  $>1 - 3$  NTU are scrutinized, along with corresponding chlorine residual levels, and actively monitored. Any sections of the water system generating high turbidity results are field-checked and flushed if required.

Turbidity events in the raw source water impact the Village's water treatment plants. The performance of the primary UV treatment is affected by increased turbidity because water that has higher turbidity absorbs a significant amount of UV light, and will therefore have a correspondingly low UV transmittance (UVT) rate. The UV system automatically increases lamp intensity to counter the lower UVT. If turbidity exceeds 5 NTUs entering the plants, the UV system will send an alarm through SCADA to notify the Water Operator, and the UV reactors will shut down. The Water Operator will immediately inform the Public Works Manager (or designate) and investigate the alarm at the plant.

During turbidity events in excess of 5 NTU, microbiological sampling and testing is increased at all sampling locations; chlorine residual sampling and testing is likewise increased; and the Village will contact VCH, who may issue a Boil Water Advisory.

### DISINFECTION FAILURES

Chlorine residuals in the Village's treated water system are monitored on a regular basis through the water sampling and testing program. If a daily sample registers below the generally accepted minimum chlorine residual of 0.2ppm, the Water Operator will first flush water through the system to attempt to bring the chlorine residual up to the minimum required. Should the results continue to not meet the minimum, the Village will immediately commence increased monitoring of all chlorine residuals in the system, including the tank, and determine the root cause of the problem. Chlorine will be added manually to the tank if required; and residuals checked frequently at all locations. The Public Works Manager (or designate) will contact VCH, who may issue a Boil Water Advisory if continued loss of residual is observed.

## APPENDIX F: EMERGENCY RESPONSE PLAN

### LOSS OF PRESSURE DUE TO HIGH DEMAND

In the event of adverse pressure loss due to high demand, Village crews will make adjustments to the system to isolate the affected section, and then take measures to supplement pressure in the affected area. The Public Works Manager (or designate) will immediately consult with VCH regarding further actions; and all water quality complaints from the public will be immediately and thoroughly investigated for potential contamination.

### WATER MAIN BREAKS

In the event of a water main break where chemical or microbiological contamination of the system is suspected, Village crews will make adjustments to the system to isolate the contaminated section from the rest of the distribution system. The Public Works Manager (or designate) will immediately consult with VCH regarding further actions; and all water quality complaints from the public will be immediately and thoroughly investigated for potential contamination. Water samples will be taken from the vicinity and downstream of the break if possible, and tested for the suspected contamination. The same procedures as noted under E. coli positive samples above will be implemented if required.

### LACK OF WATER DUE TO DROUGHT OR OTHER CAUSES

In the event of a lack of water due to low streamflow or other causes affecting supply (such as debris torrents, lack of safe access to intakes, or Village-wide water use in excess of supply), an escalating conservation system is implemented to address the lack of water in the system.

Conservation efforts now commence annually from June 1 through to September 30 of each year, in accordance with Level One of the Village's Outdoor Water Use Bylaw. Further stages of conservation are then utilized as required to reduce the outdoor use of water in the Village, combined with extensive public notification (via electronic notifications, printed media delivered to every home, and town hall meetings). The highest level of restrictions are intended for emergent situations which directly affect the supply of water in the system. Table 2 outlines the Village's 2016 outdoor water use conservation levels. Conservation Level 2 was in effect from July to September in 2016.

Village Public Works crews can switch valves within the water system itself, based on water availability from either creek, to ensure continuous Village supply. This "balancing" of supply vs. demand occurred often during the drought conditions of 2016.

The GPM of the water flowing from the creek intakes to the respective water treatment plants is monitored daily, during the water sampling and testing program. If the water flow entering either plant is compromised, Village crews ascertain the root cause of the problem (i.e. whether the decrease is due to a blockage or drought) and work to either repair (if blocked) and/or mitigate the impact on the system as a whole by implementing conservation measures noted in Table 2.

# APPENDIX F: EMERGENCY RESPONSE PLAN

Table 2 Outdoor Water Use Conservation Levels

	ACTIVITY	CONSERVATION LEVEL 1	CONSERVATION LEVEL 2	CONSERVATION LEVEL 3
RESIDENTIAL & COMMERCIAL USES	Watering lawns, 4am – 9am only  Newly planted lawns may be watered outside allowed times with a municipal permit displayed	Even-numbered addresses: Monday, Wednesday and Saturday.  Odd-numbered addresses: Tuesday, Thursday and Sunday.	Even-numbered addresses: Monday only  Odd-numbered addresses: Thursday only	Prohibited
	Watering flowers, vegetables, planters, shrubs, trees	No restrictions	Only by hand using spring-loaded nozzle, containers, or drip irrigation. Sprinklers and soaker hoses prohibited	Prohibited
	Use of pools, spas, fountains/ponds	No restrictions. Must have a recirculation pump. “One-time-through” uses are prohibited at all times		Filling prohibited
	Washing outdoor impermeable surfaces such as driveways, buildings, sidewalks and roads, including pressure washing	No restrictions	Only for health and safety purposes, or to prepare a surface for painting or similar treatment	Prohibited
	Washing vehicles and boats	Only with a hose using spring-loaded shut off	Only by bucket	Prohibited, except for windows, lights, and license plates
	Flushing boat engines	No restrictions		4 minutes maximum
	Filling outdoor water storage	No restrictions		Prohibited
	PUBLIC USES	Watering of school property, including Lions Bay Field	No restrictions	Minimum to maintain in useable condition
Watering of parks, municipal lawns, and grassed boulevards 1am to 6am only		Even-numbered addresses: Monday and Wednesday. Odd-numbered addresses: Tuesday and Thursday. Parks Friday only	Even-numbered addresses: Monday only Odd-numbered addresses: Thursday only	Prohibited
Flushing of water mains and hydrants		Only for safety or public health reasons		

## APPENDIX F: EMERGENCY RESPONSE PLAN

During the drought of 2016, Village crews also repurposed 2 water storage tanks located at Brunswick (42,000 USG) and at the top of Oceanview Road (100,000 USG) to be used as stand-alone emergency non-potable water supply in the event of a fire. Both of these tanks are kept filled during the summer months, and are entirely separate from the potable water system.

Village crews also capture water from the daily water sampling program, store it in truck-mounted totes, and then use it to water municipal planted areas. Crews also fill rain barrels and totes located at the community garden and the native plant garden, so that recycled water is used for irrigation of these areas, as opposed to drinking water. Lions Bay Fire Rescue also discontinue any training activities that draw water from the potable water system.

When a lack of water continues despite conservation efforts, Village staff will liaise with EMBC, VCH, and FLNRO for both information and a consolidated response to events as they unfold. Village staff then arrange water tankers to truck in potable water and use this method to fill one or both tanks to keep potable water in the water system. Neighboring municipalities are also informed in the event they can lend assistance. As an example, in late 2014 after debris torrents had compromised one intake and the remaining intake's flow was similarly compromised, the District of West Vancouver allowed potable water to be drawn from their system via tanker trucks to the Village to fill the Village tanks and also allowed Lions Bay residents to utilize shower facilities at no charge at Gleneagles Community Centre during this isolated event.

Increased testing and monitoring of the water system is undertaken, in conjunction with VCH, until the system as a whole is once again restored.

# APPENDIX G: VANCOUVER COASTAL HEALTH PERMIT TO OPERATE

# APPENDIX G: VANCOUVER COASTAL HEALTH PERMIT TO OPERATE



## PERMIT TO OPERATE

### Drinking Water System 301-10,000 Connections

**Facility Number:** 3317552347  
**Name of Facility:** Lions Bay Magnesia Creek Water System  
**Address:** Upper Sunset Road  
 Lions Bay, BC  
**Owner:** Municipality of The Village of Lions Bay

**Conditions:**

1. Submit weekly water samples for bacteriological testing at sites approved by VCH.
2. Chlorine residuals must be recorded daily at locations approved by VCH.
3. Biannual flushing on the entire distribution system.
4. Daily turbidity testing.
5. Annual chemical testing of source
6. Submit annual updated ERP to VCH.

September 29, 2010  
 \_\_\_\_\_  
**Effective Date**



\_\_\_\_\_  
**Rod Schluter**  
 Environmental Health Officer

*This permit must be displayed  
 in a conspicuous place and is nontransferable.*



# APPENDIX G: VANCOUVER COASTAL HEALTH PERMIT TO OPERATE



## PERMIT TO OPERATE

### Drinking Water System 301-10,000 Connections

**Facility Number:** 3317552348  
**Name of Facility:** Lions Bay Harvey Creek Water System  
**Address:** Upper Oceanview Road  
 Lions Bay, BC  
**Owner:** Municipality of The Village of Lions Bay  
**Conditions:**

1. Submit weekly water samples for bacteriological testing at sites approved by VCH.
2. Chlorine residuals must be recorded daily at locations approved by VCH.
3. Biannual flushing on the entire distribution system.
4. Daily turbidity testing.
5. Annual chemical testing of source
6. Submit annual updated ERP to VCH.

September 29, 2010  
 \_\_\_\_\_  
**Effective Date**



\_\_\_\_\_  
**Rod Schluter**  
 Environmental Health Officer

*This permit must be displayed  
 in a conspicuous place and is nontransferable.*



## APPENDIX H: EOCP FACILITY CLASSIFICATION

APPENDIX H: EOCP FACILITY CLASSIFICATION

**ENVIRONMENTAL OPERATORS CERTIFICATION PROGRAM  
Facility Classification**

This is to certify that

***Village of Lions Bay - Magnesia Water Treatment  
Plant***

has been classified by the Environmental Operators Certification Program in accordance with the guidelines established with the Association of Boards of Certification as a

**Class I Facility**

Dated at Burnaby, BC on April 12, 2016



Secretary - Certification Board



President - Certification Board

Facility No. 2330



This certificate must hold the EOCP embossed seal.  
Member of the Association of Boards of Certification  
A society incorporated under the Society Act, S.B.C. S-28724

APPENDIX H: EOCP FACILITY CLASSIFICATION

**ENVIRONMENTAL OPERATORS CERTIFICATION PROGRAM**

**Facility Classification**

This is to certify that

**Village of Lions Bay - Harvey Water Treatment Plant**

has been classified by the Environmental Operators Certification Program in accordance with the guidelines established with the Association of Boards of Certification as a

**Class I Facility**

Dated at Burnaby, BC on April 12, 2016



Secretary - Certification Board



President - Certification Board

Facility No. 2329



This certificate must hold the EOCP embossed seal.  
Member of the Association of Boards of Certification  
A society incorporated under the Society Act, S.B.C. S-28724

# APPENDIX H: EOCP FACILITY CLASSIFICATION

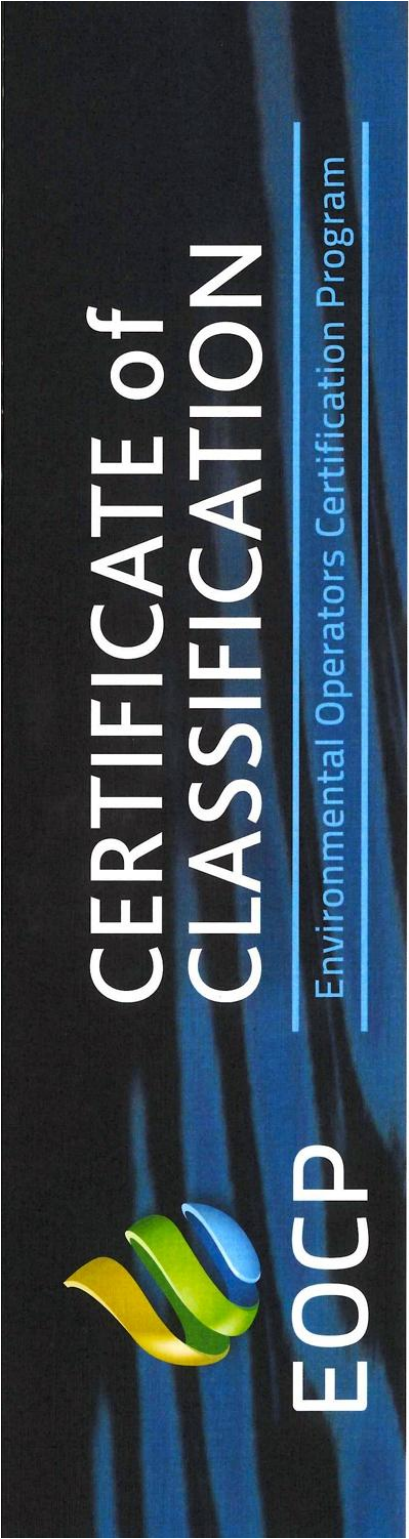

This is to certify that:



## Village of Lions Bay Water Distribution System

Facility No. 675

has been classified as a

**Class II System**

*Pat Miller*

CHAIR, BOARD OF DIRECTORS

*Helander*

CHIEF EXECUTIVE OFFICER

Dated: July 28, 2003

At: Burnaby, BC

A society incorporated under the Society Act, S.B.C. S-28724

## APPENDIX I: EOCP OPERATOR CERTIFICATES

# APPENDIX I: EOCP OPERATOR CERTIFICATES



# APPENDIX I: EOCP OPERATOR CERTIFICATES

**ENVIRONMENTAL OPERATORS CERTIFICATION PROGRAM**

**Certificate of Qualification**  
This is to certify that:

**Alberto Urrutia**

By Examination Has Qualified As A

**Water Distribution System Operator**

and certifies that he/she has met the established qualifications and has the ability to efficiently operate and maintain a specified maximum size and type of water distribution system designated as follows:

**Level II**

Secretary - Certification Board  
July 12, 2006

Chairman - Certification Board  
Certificate No: 4766

Member of Association of Boards of Certification  
Affiliate of B.C. Water and Waste Association

This certificate shall be in full force and effect when accompanied by an annual renewal seal  
A Society Incorporated under the Society Act, S.B.C. S-28724













# APPENDIX I: EOCP OPERATOR CERTIFICATES

## ENVIRONMENTAL OPERATORS CERTIFICATION PROGRAM

### Course Completion Certificate

This is to certify that

**Garth J. Begley**

By Examination Has Qualified As A

**Chlorine Handler**

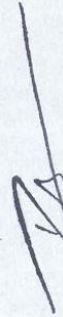

Secretary - Certification Board

May 6, 2005

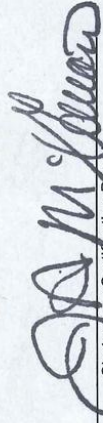

Chairman - Certification Board

Certificate No. CH-713



# APPENDIX I: EOCP OPERATOR CERTIFICATES

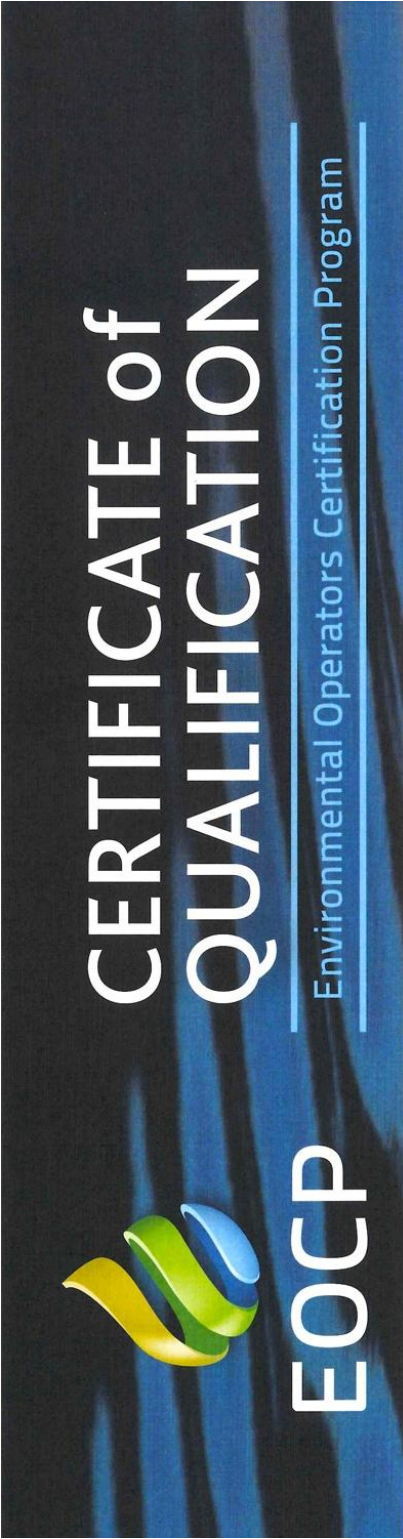

This is to certify that:

## Garth J. Begley

By examination has qualified as a

### Water Distribution System Operator Level I



Certification No. 9324

Valid until December 31, 2017

Garth J. Begley

CHAIR, BOARD OF DIRECTORS

CHIEF EXECUTIVE OFFICER

A society incorporated under the Society Act, S.B.C. S-28724

APPENDIX I: EOCP OPERATOR CERTIFICATES

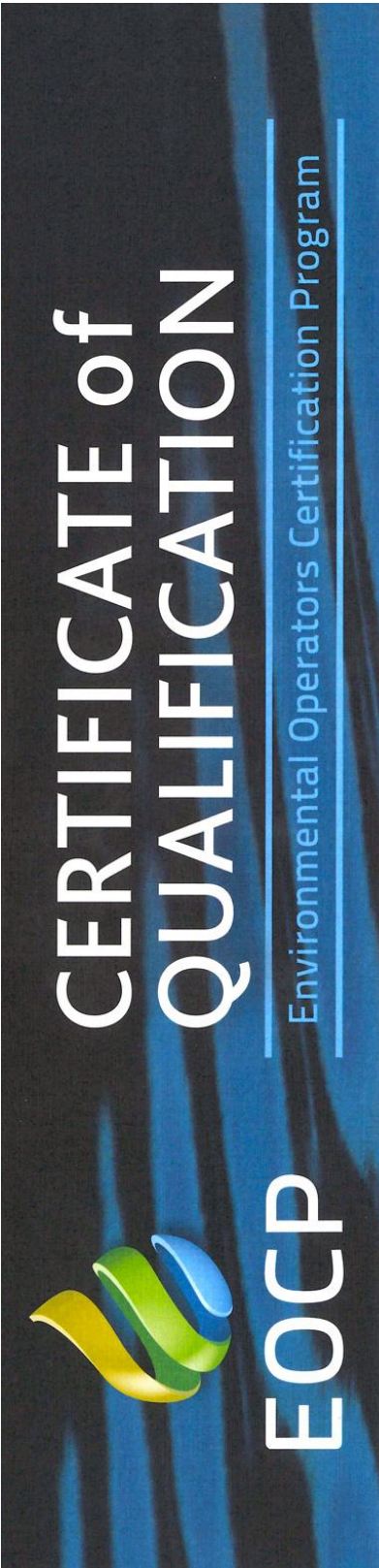

This is to certify that:

**William K. Emo**

By examination has qualified as a

**Water Distribution System Operator  
Level I**



Certification No. 8469  
August 10, 2016  
At Burnaby, BC

*Jack Miller*

CHAIR, BOARD OF DIRECTORS

*Helaine*

CHIEF EXECUTIVE OFFICER

A society incorporated under the Society Act, S.B.C. S-28724

Intentionally Blank



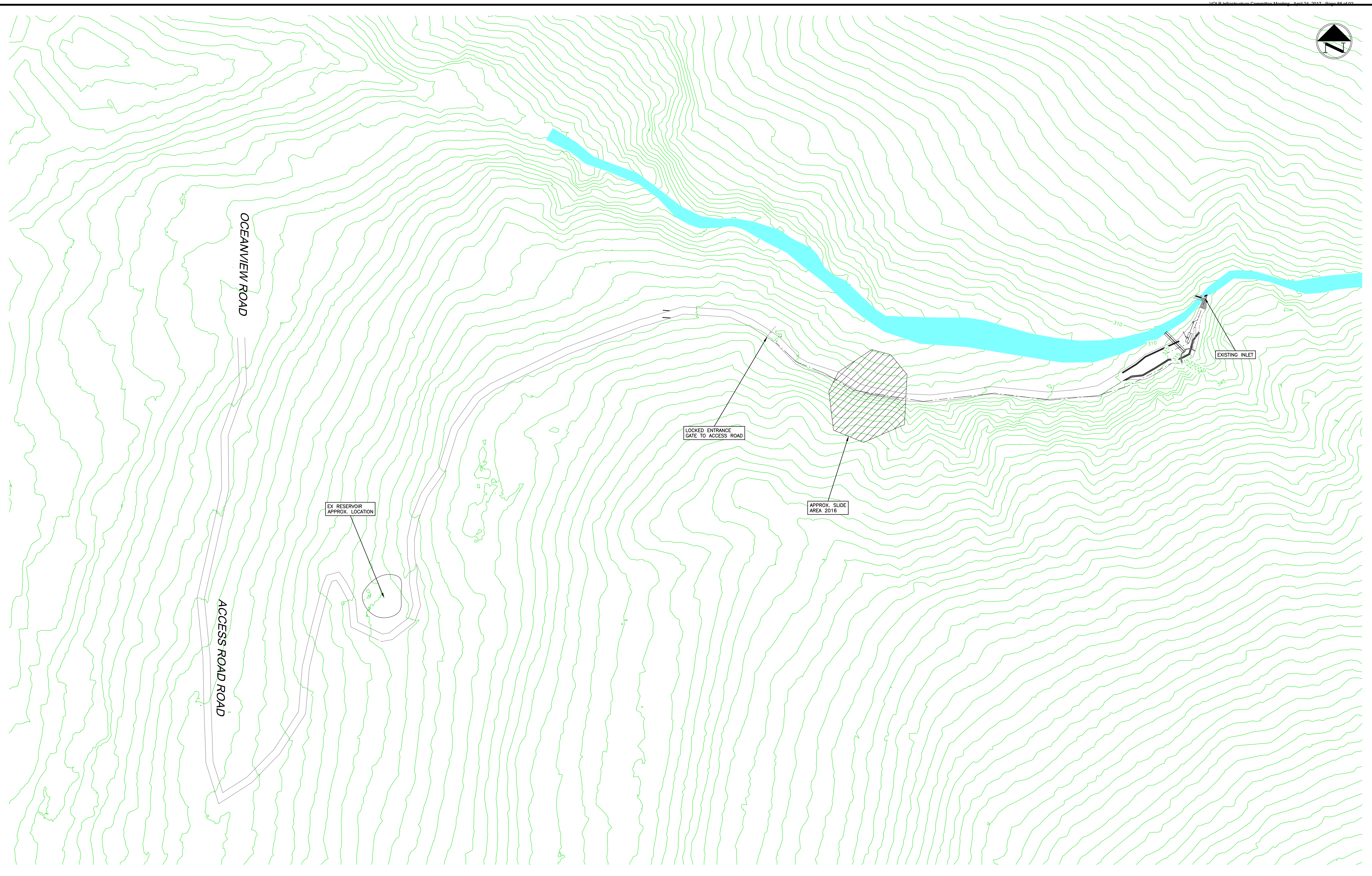
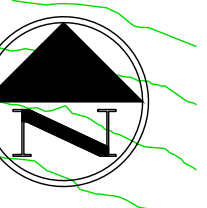

4	MAR. 15.17	FUNDING APPROVAL SET	ZM		
3	FEB. 15.17	GENERAL REVISION	AGC		
2	FEB. 15.16	ISSUED FOR CONSTRUCTION	NGB		
1	FEB. 03.16	ISSUED FOR HARVEY ROAD SLIDE	NGB		
no.	date	revision	chk'd	no.	date

client  
**VILLAGE OF LIONS BAY**

project  
**HARVEY CREEK INTAKE ACCESS ROAD  
 LIONS BAY, BC**

www.creus.ca

**CREUS Engineering Ltd**  
 Civil Engineers

P: 604-987-9070 F: 604-987-9071  
 Suite 610, East Tower, 221 Esplanade West, North Vancouver, BC V7M 3J3

COPYRIGHT RESERVED. THIS DRAWING AND DESIGN ARE AND AT ALL TIMES REMAIN THE EXCLUSIVE PROPERTY OF CREUS ENGINEERING LTD. AND CANNOT BE USED, REPRODUCED OR DISTRIBUTED WITHOUT WRITTEN CONSENT. © 2006 CREUS ENGINEERING LTD.

approved

designed by K.B.H.  
 drawn by N.G.B.  
 checked by F.M.C.  
 date NOV.04.14

title  
**KEY PLAN**

scales hor: 1:1000 vert: -  
 file no. **13160**  
 drawing no. **KEY-1** rev. **4**

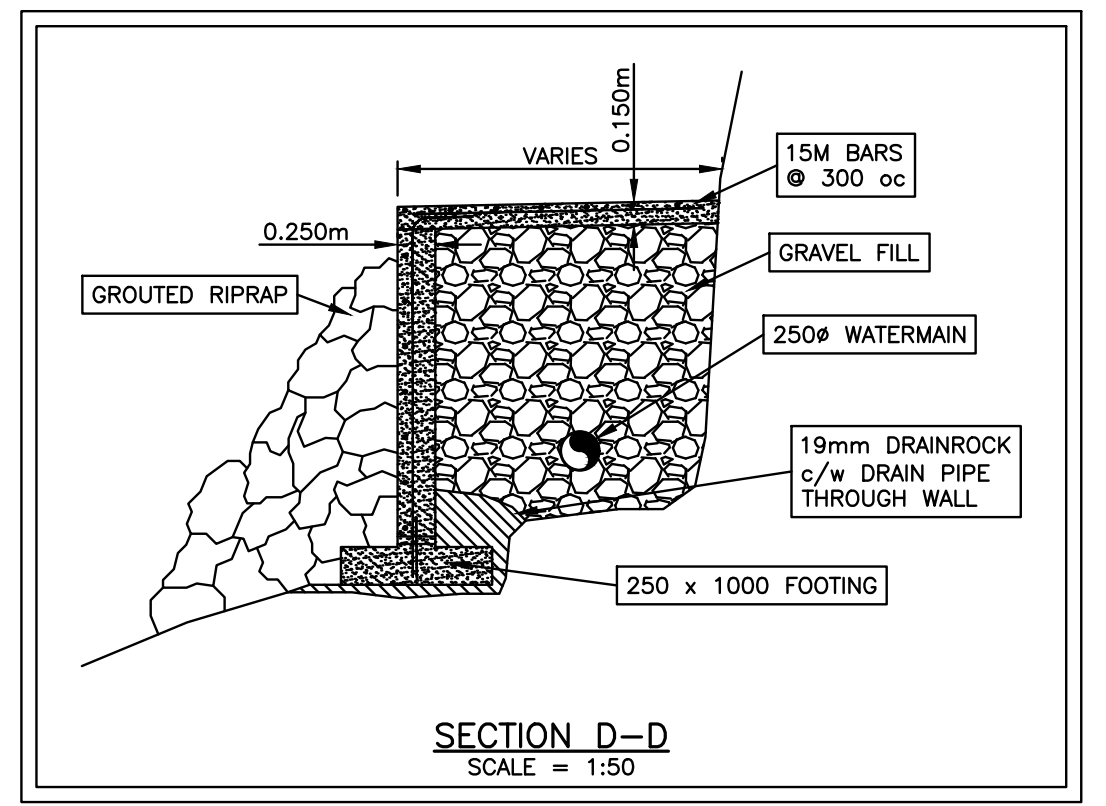
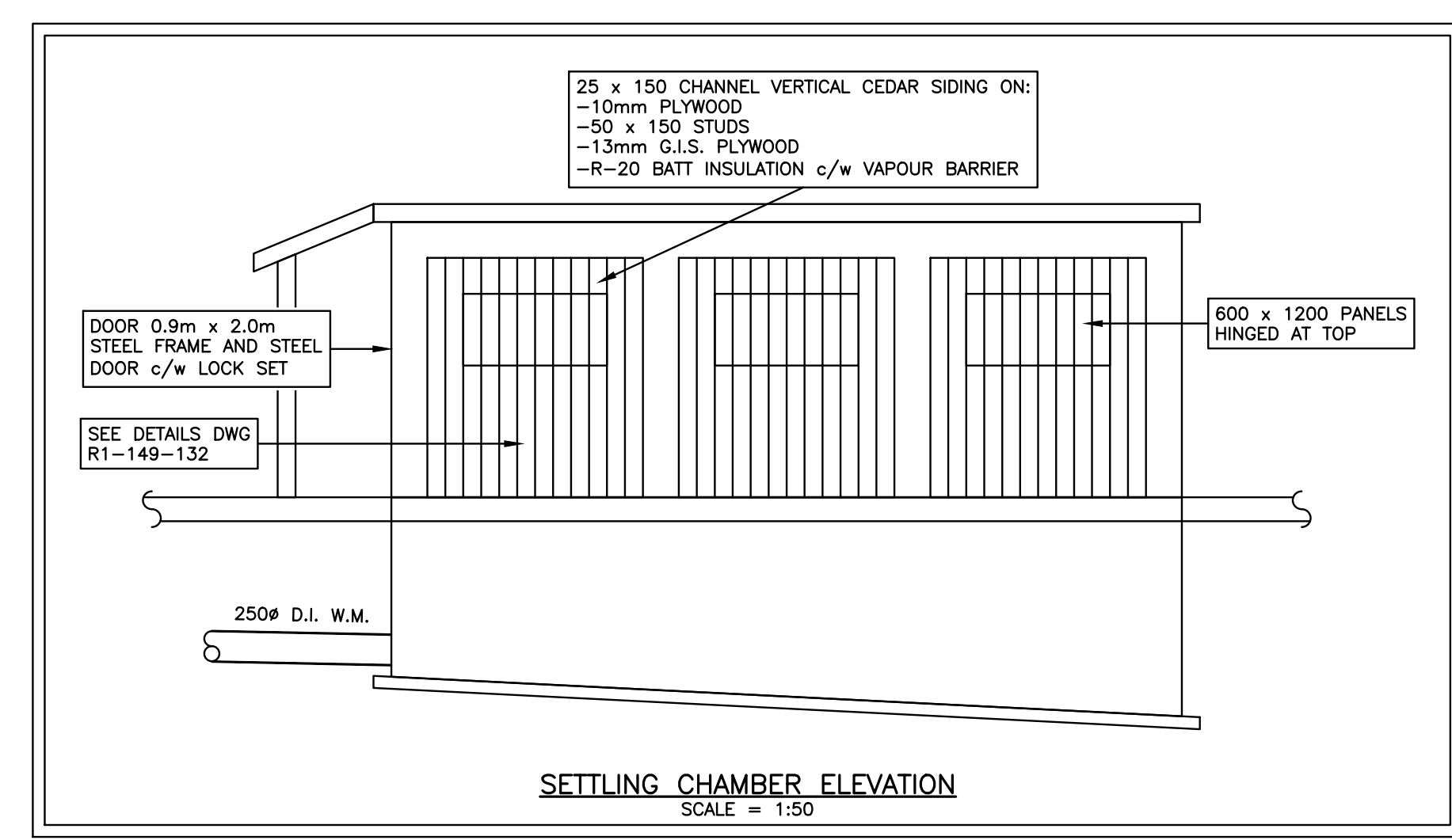
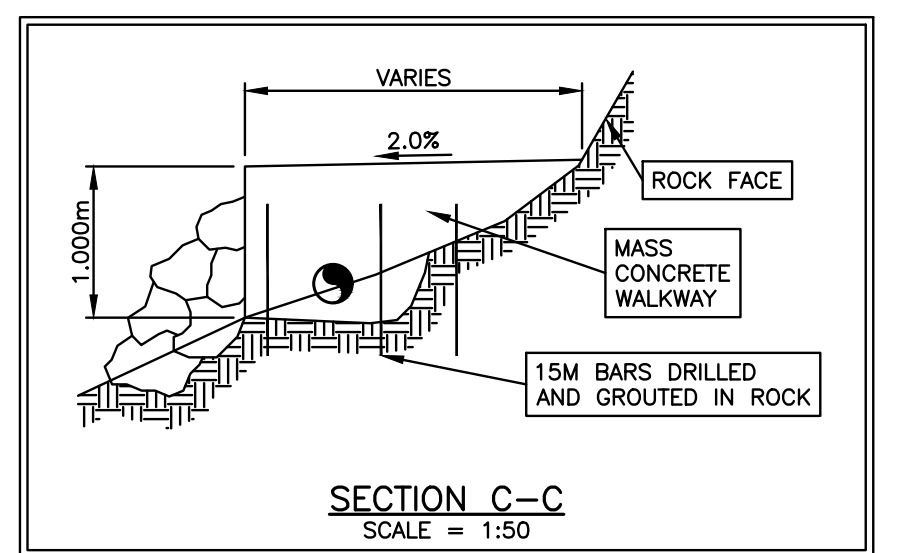
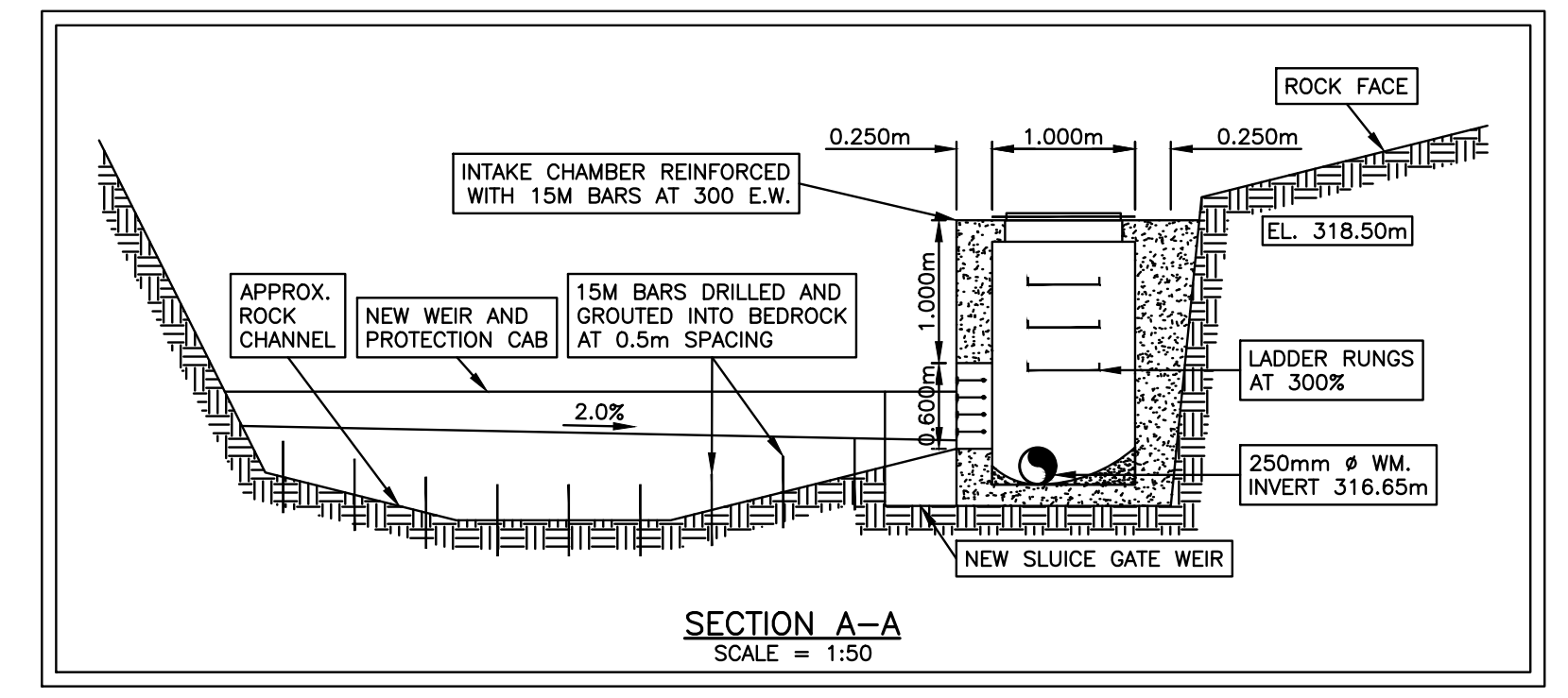
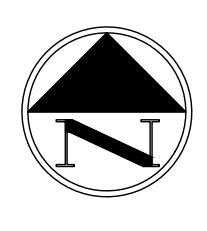
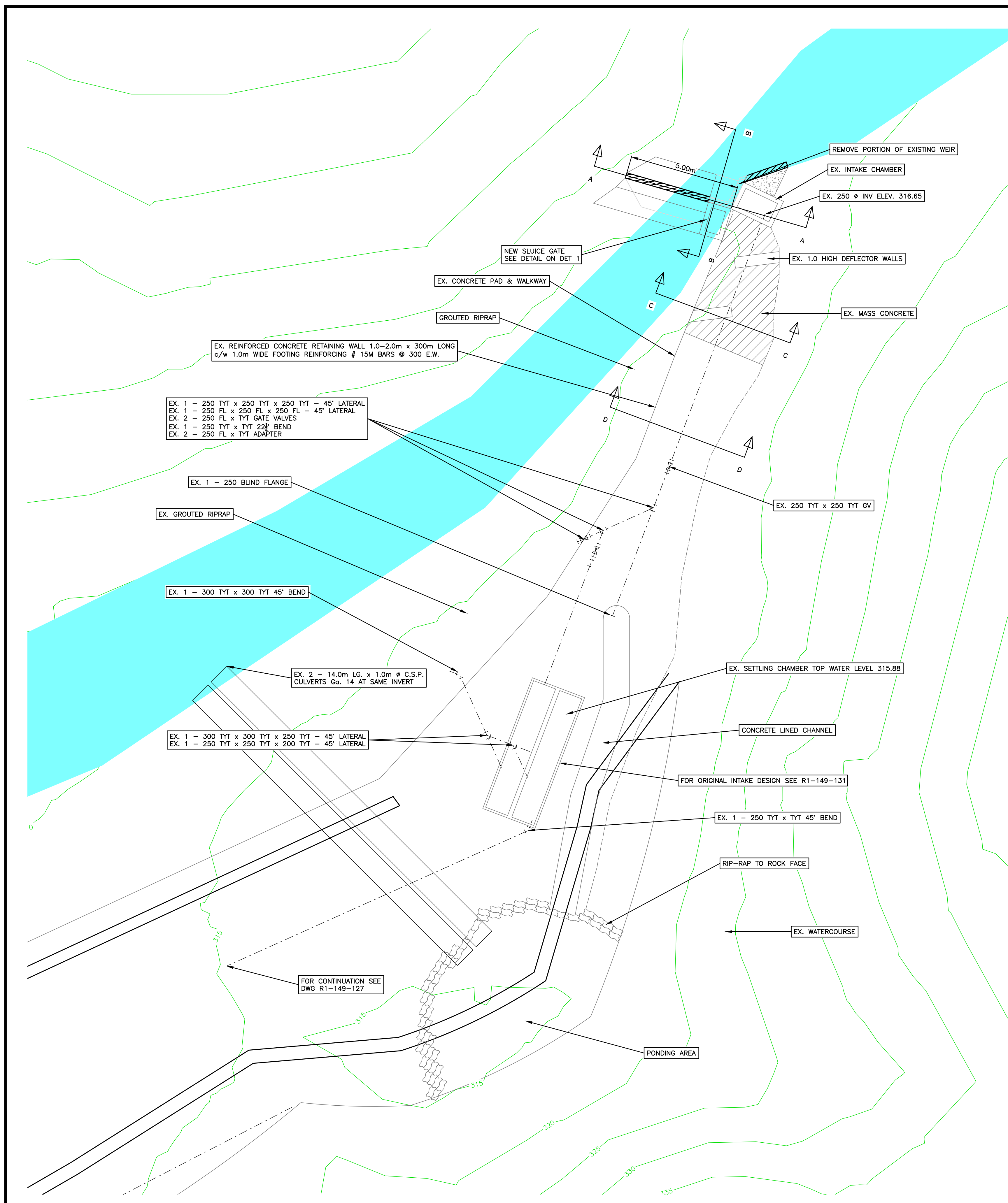

no.	date	revision	chk'd	no.	date	revision	chk'd
2	MAR. 15.17	FUNDING APPROVAL SET	ZM				
1	FEB. 15.17	GENERAL REVISION	AGC				

client	VILLAGE OF LIONS BAY
project	HARVEY CREEK INTAKE ACCESS ROAD LIONS BAY, BC

**CREUS Engineering Ltd**  
Civil Engineers

P: 604-987-9070 F: 604-987-9071  
Suite 610, East Tower, 221 Esplanade West, North Vancouver, BC V7M 3J3

COPYRIGHT RESERVED. THIS DRAWING AND DESIGN ARE AND AT ALL TIMES REMAIN THE EXCLUSIVE PROPERTY OF CREUS ENGINEERING LTD. AND CANNOT BE USED, REPRODUCED OR DISTRIBUTED WITHOUT WRITTEN CONSENT. © 2008 CREUS ENGINEERING LTD.

approved  
designed by K.B.H.  
drawn by N.G.B.  
checked by F.M.C.  
date NOV.04.14

scales		hor: 1:100	vert: -
file no.		13160	
drawing no.	KEY-2	rev.	2

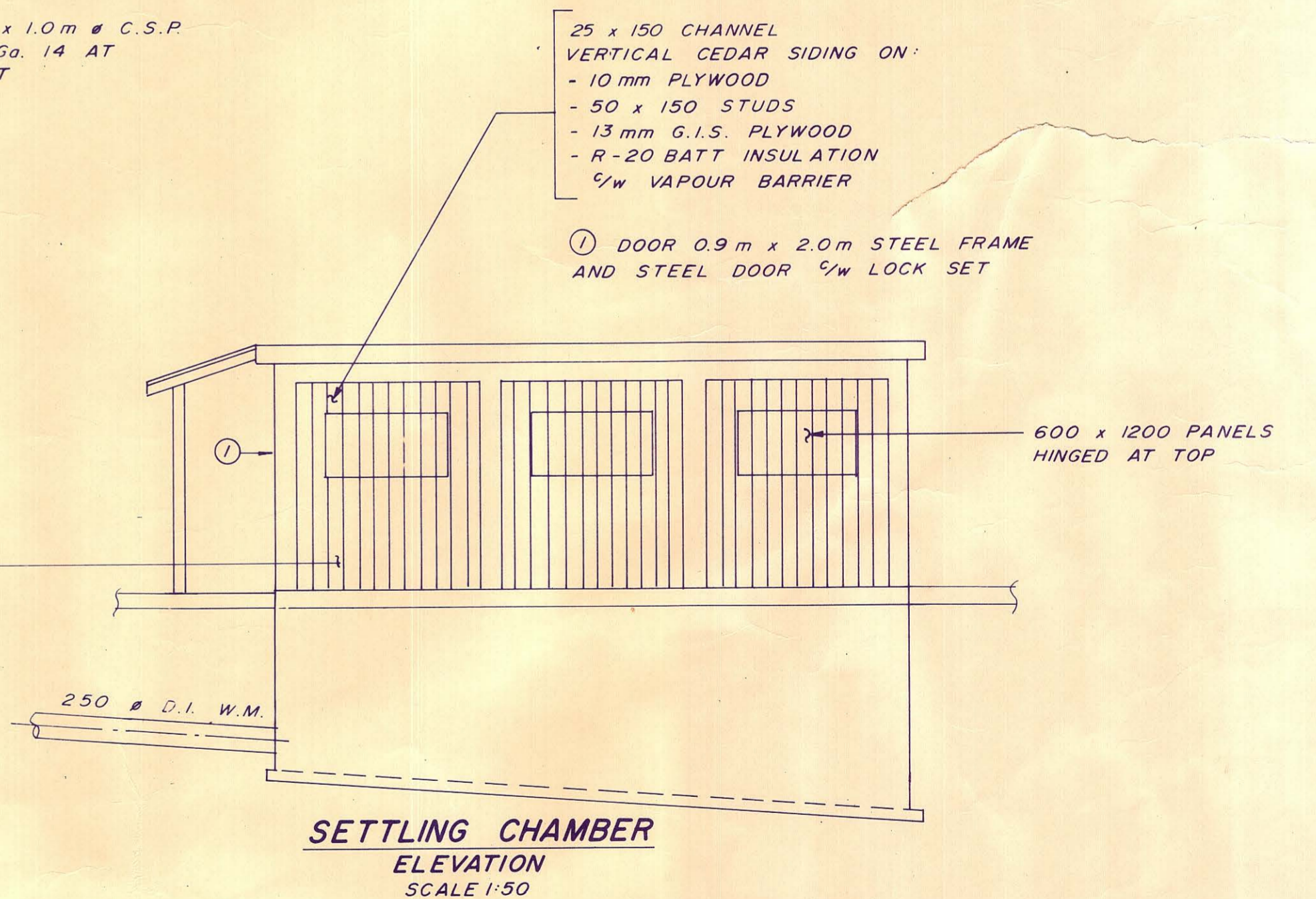
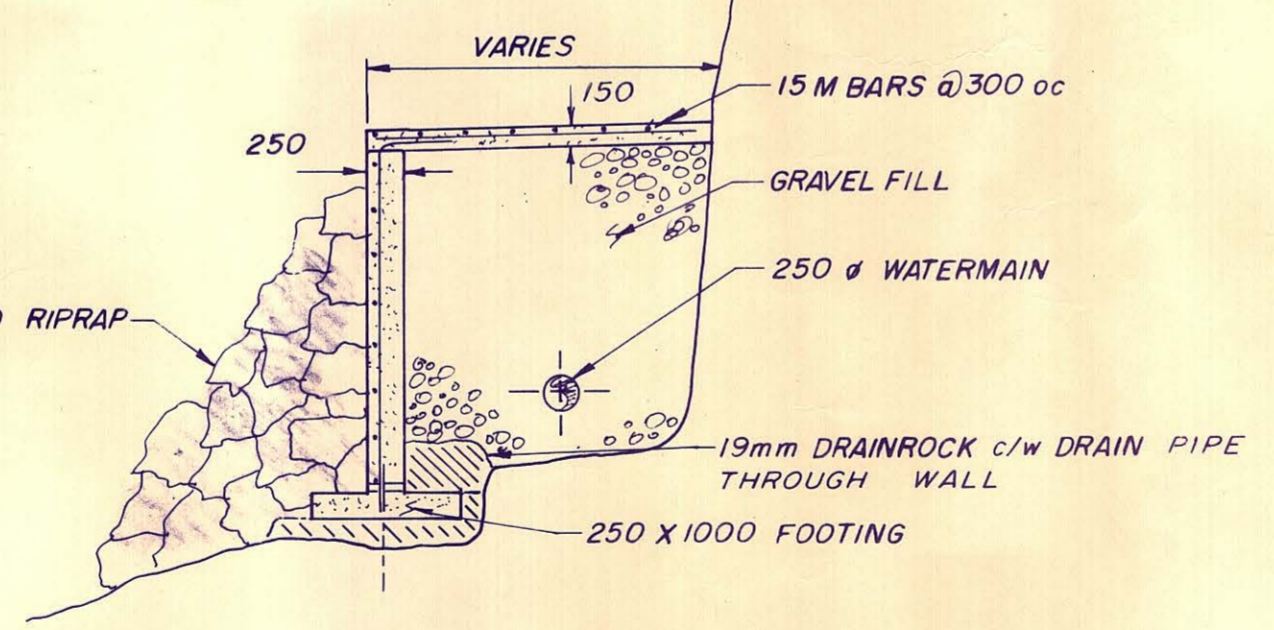
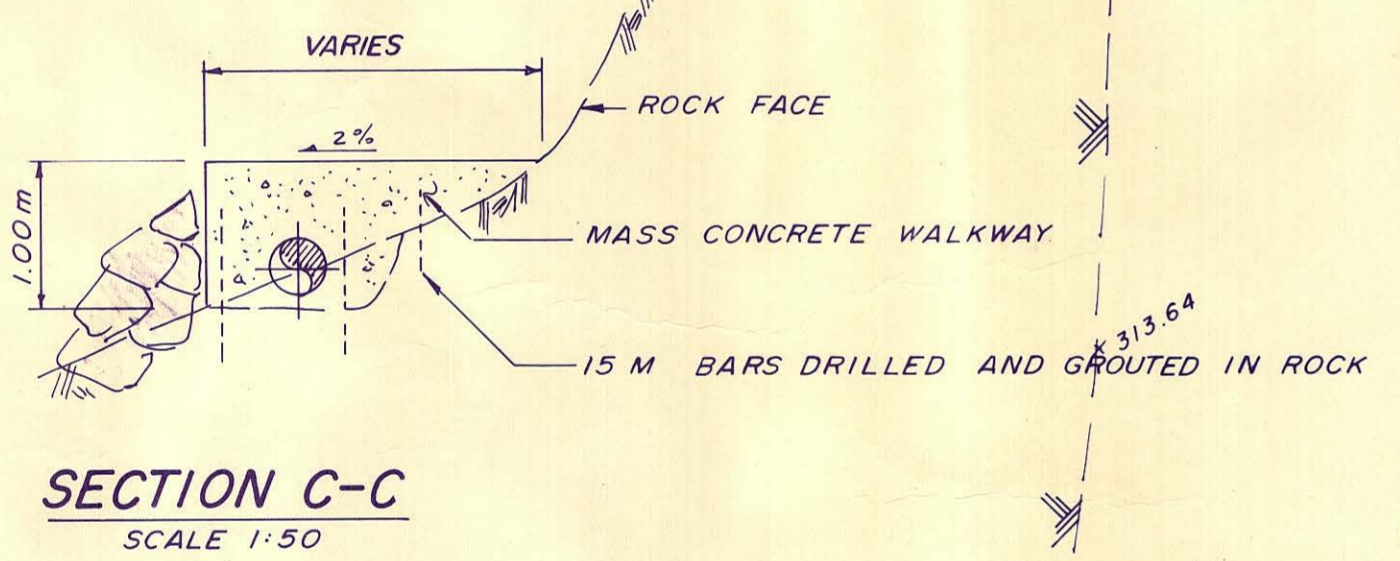
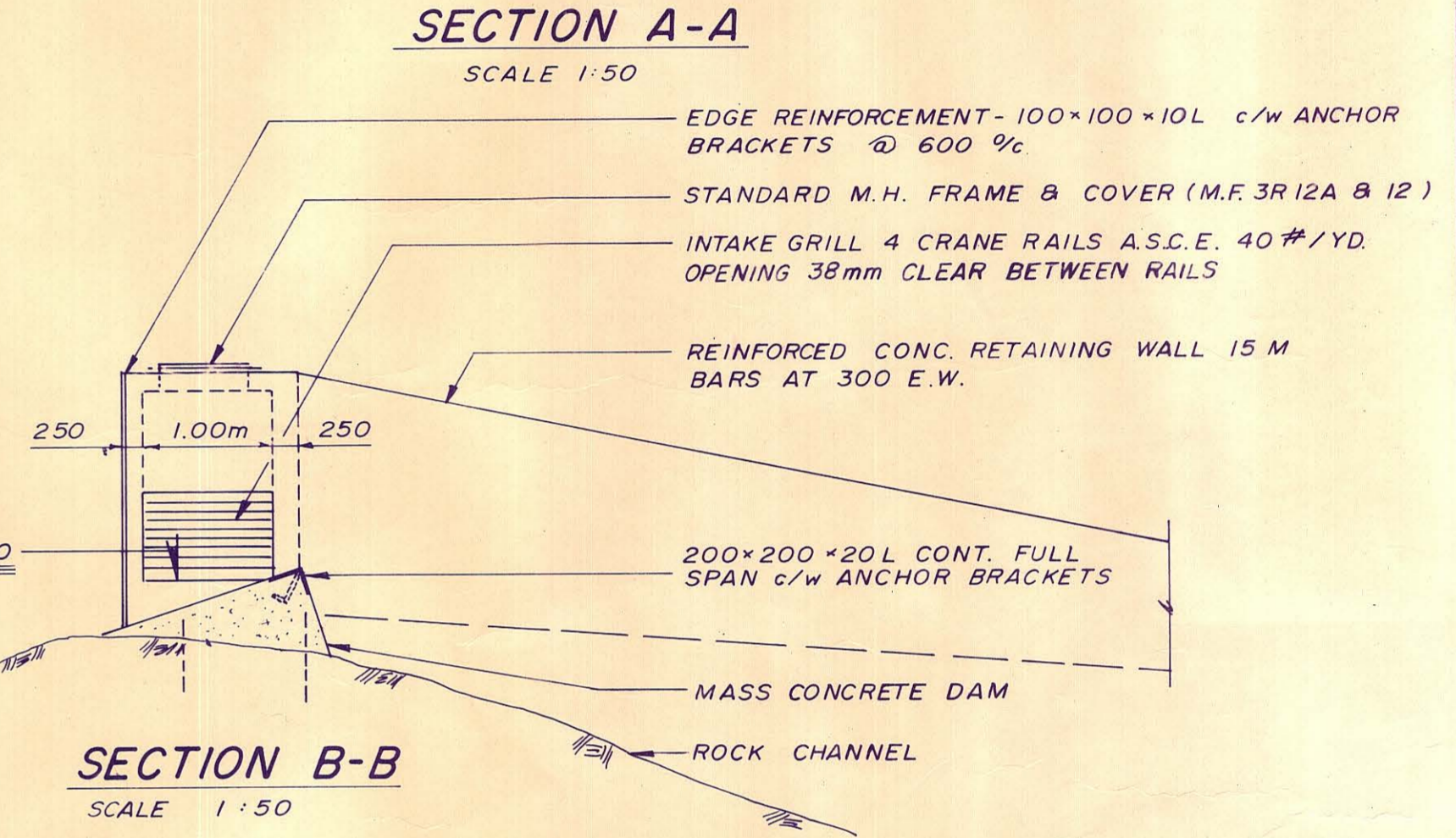
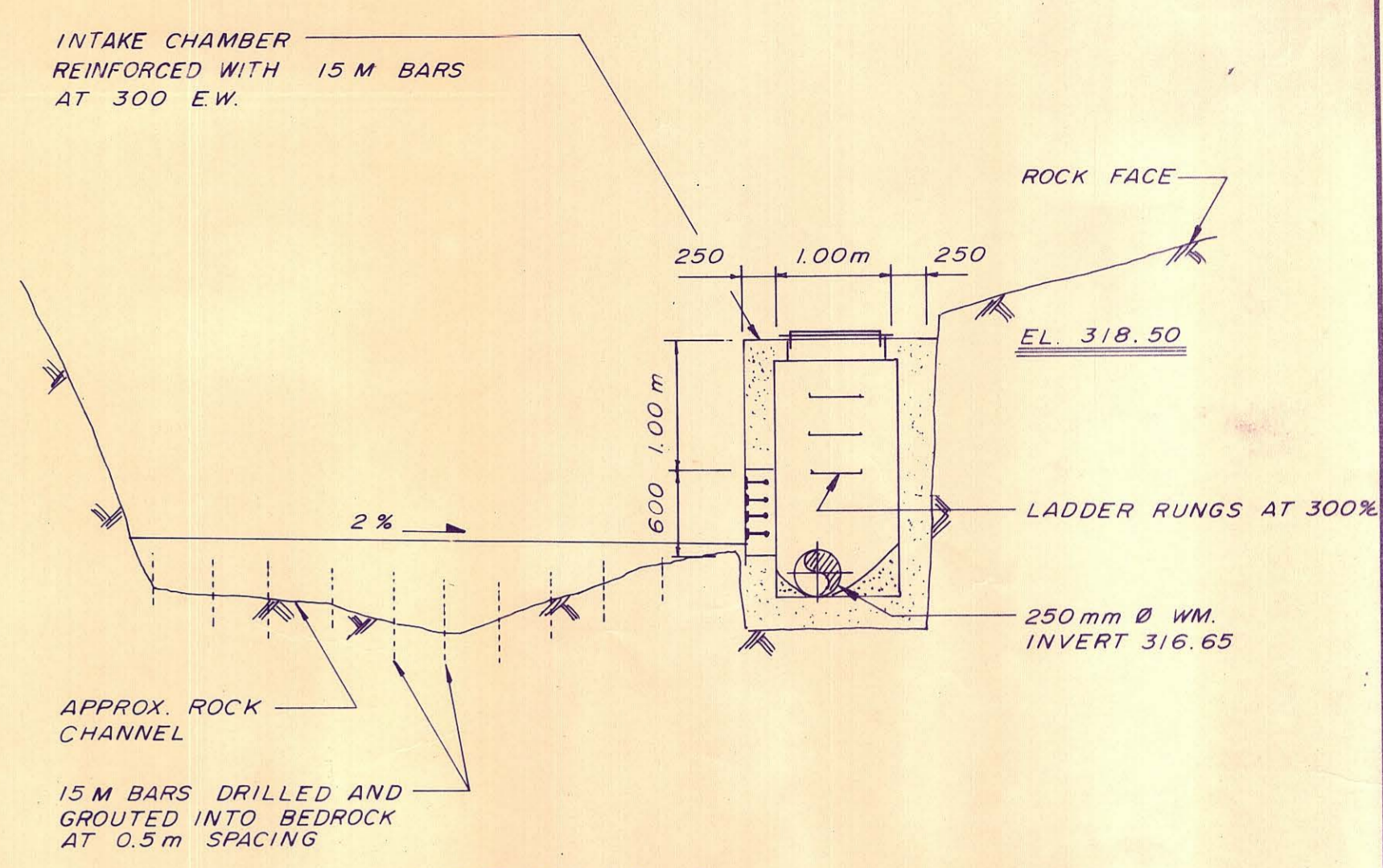
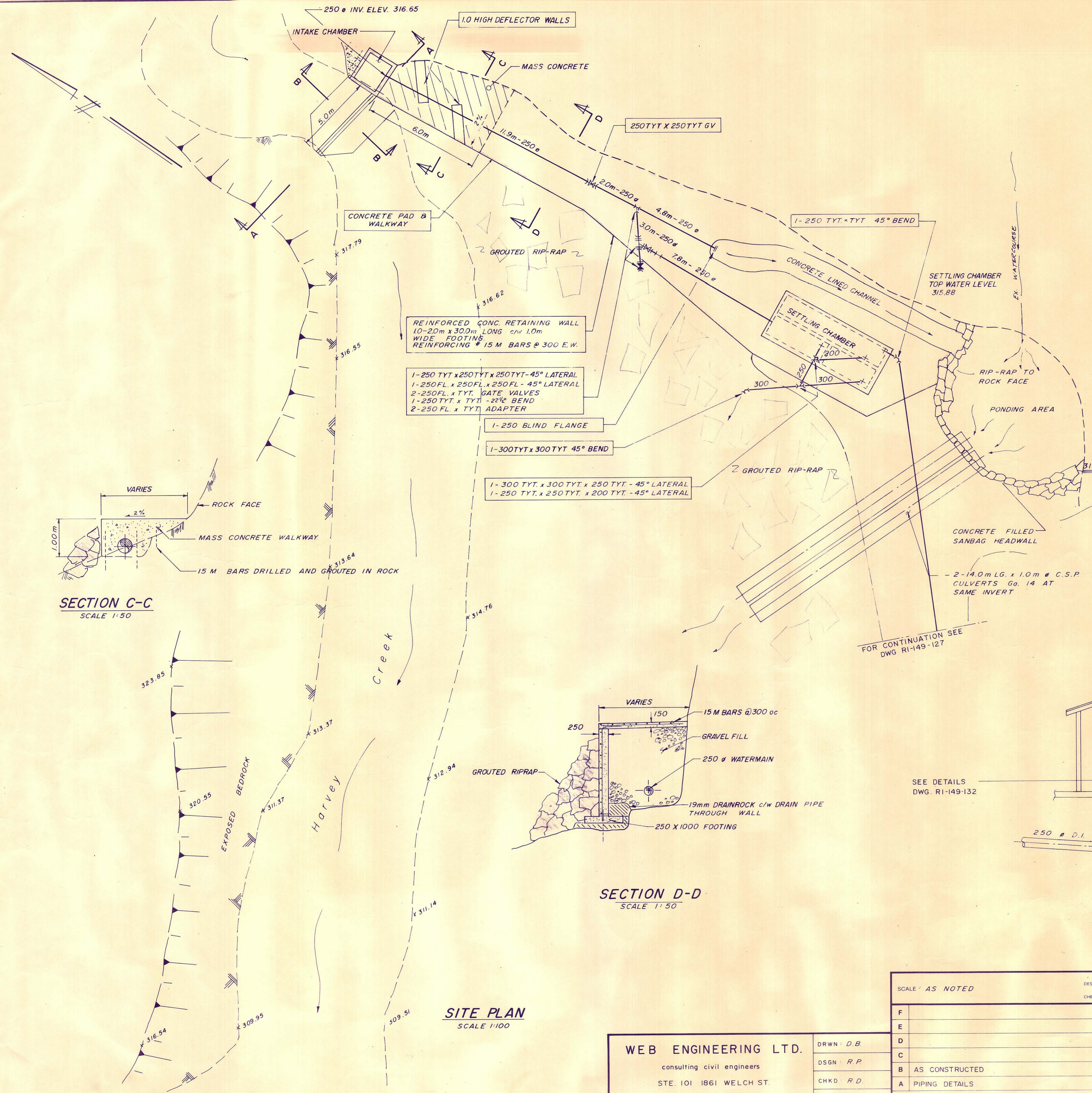

**SITE PLAN**  
SCALE 1:100

**WEB ENGINEERING LTD.**  
consulting civil engineers  
STE. 101 1861 WELCH ST.  
North Vancouver, B.C.

DRWN: D.B.  
DSGN: R.P.  
CHKD: R.D.  
DATE: APR/84

SCALE: AS NOTED

DESIGNED	DATE
CHECKED	DATE
F	
E	
D	
C	
B	AS CONSTRUCTED
A	PIPING DETAILS
DATE: APR/84	WEB No. 425 - 31

PROVINCE OF BRITISH COLUMBIA  
MINISTRY OF TRANSPORTATION AND HIGHWAYS  
DESIGN AND SURVEYS BRANCH

**VILLAGE OF LIONS BAY**  
**WATERWORKS**  
**HARVEY CREEK - INTAKE DETAILS**

PREPARED UNDER THE DIRECTION OF	APPROVED FOR USE IN CONSTRUCTION	EXAMINED AND ACCEPTED
DATE	DIRECTOR OF HIGHWAY DESIGN AND SURVEYS DATE	EXECUTIVE DIRECTOR ENGINEERING DATE
INDEX	NEG No	FILE No
	PROJECT No	REGION
		DRAWING No
		R1-149-131

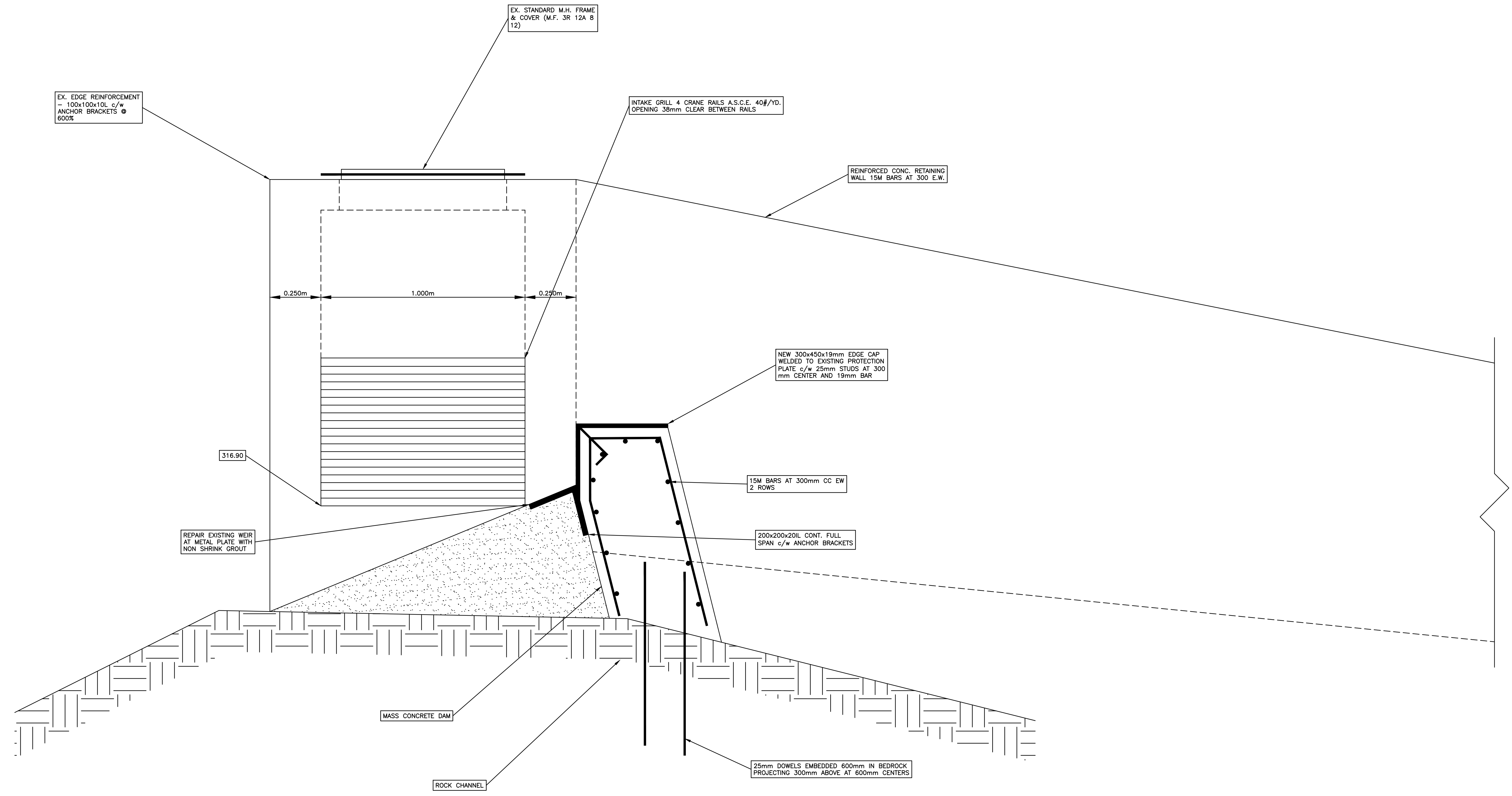

no.	date	revision	chk'd	no.	date	revision	chk'd
1	MAR.15.17	FUNDING APPROVAL SET	ZM				

client  
VILLAGE OF LIONS BAY

project  
HARVEY CREEK INTAKE ACCESS ROAD  
LIONS BAY, BC

www.creus.ca

# CREUS Engineering Ltd

Civil Engineers

P: 604-987-9070 F: 604-987-9071  
Suite 610, East Tower, 221 Esplanade West, North Vancouver, BC V7M 3J3

COPYRIGHT RESERVED. THIS DRAWING AND DESIGN ARE AND AT ALL TIMES REMAIN THE EXCLUSIVE PROPERTY OF CREUS ENGINEERING LTD. AND CANNOT BE USED, REPRODUCED OR DISTRIBUTED WITHOUT WRITTEN CONSENT. © 2009 CREUS ENGINEERING LTD.

approved

designed by K.B.H.  
drawn by N.G.B.  
checked by F.M.C.  
date NOV.04.14

title  
**INTAKE SECTION B-B**

scales  
hor: 1:10 vert: -

file no.  
13160

drawing no.  
XS B-B

rev.  
1

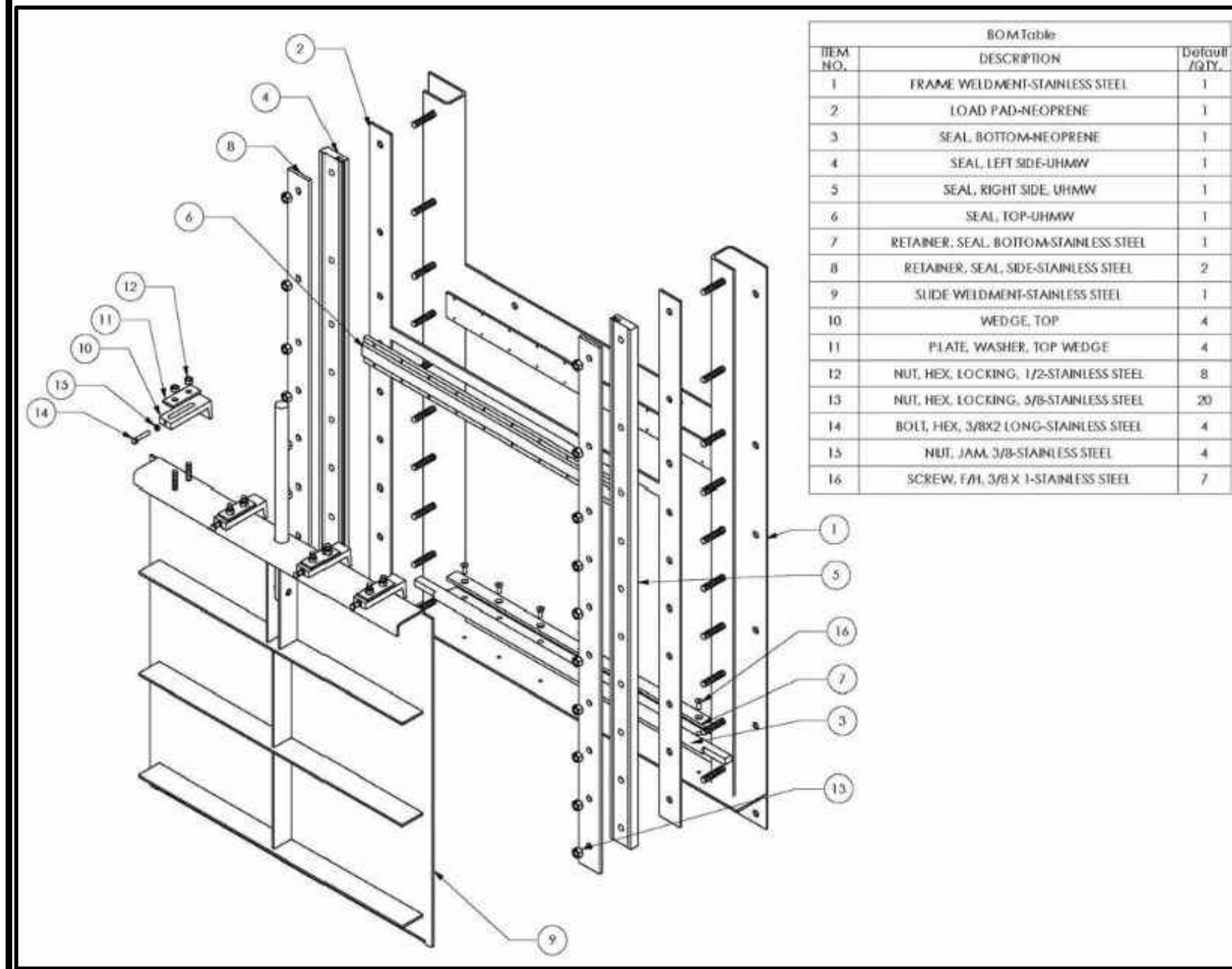

BOM Table		
ITEM NO.	DESCRIPTION	QUANTITY
1	FRAME WELDMENT-STAINLESS STEEL	1
2	LOAD PAD-NEOPRENE	1
3	SEAL BOTTOM-NEOPRENE	1
4	SEAL LEFT SIDE-URHMW	1
5	SEAL RIGHT SIDE-URHMW	1
6	SEAL TOP-URHMW	1
7	RETAINER, SEAL, BOTTOM-STAINLESS STEEL	1
8	RETAINER, SEAL, SIDE-STAINLESS STEEL	2
9	SLIDE WELDMENT-STAINLESS STEEL	1
10	WEDGE, TOP	4
11	PLATE, WASHER, TOP WEDGE	4
12	NUT, HEX, LOCKING, 1/2"-STAINLESS STEEL	8
13	NUT, HEX, LOCKING, 3/8"-STAINLESS STEEL	20
14	BOLT, HEX, 3/8"x2 LONG-STAINLESS STEEL	4
15	NUT, 1/4"x3/8"-STAINLESS STEEL	4
16	SCREW, PAN, 3/8"x 1"-STAINLESS STEEL	7

no.	date	revision	chk'd	no.	date	revision	chk'd
1	FEB. 15.17	GENERAL REVISION	AGC				

client VILLAGE OF LIONS BAY  
 project HARVEY CREEK INTAKE ACCESS ROAD  
 LIONS BAY, BC

www.creus.ca

**CREUS Engineering Ltd**  
 Civil Engineers  
 P: 604-987-9070 F: 604-987-9071  
 Suite 610, East Tower, 221 Esplanade West, North Vancouver, BC V7M 3J3

COPYRIGHT RESERVED. THIS DRAWING AND DESIGN ARE AND AT ALL TIMES REMAIN THE EXCLUSIVE PROPERTY OF CREUS ENGINEERING LTD. AND CANNOT BE USED, REPRODUCED OR DISTRIBUTED WITHOUT WRITTEN CONSENT. © 2009 CREUS ENGINEERING LTD.

approved	designed by K.B.H.	title
	drawn by A.G.C.	
	checked by F.M.C.	
	date NOV.04.14	

STANDARD DETAILS

scales	hor: -	vert: -
file no.	13160	
drawing no.	DET-1	rev. 1